

Digital Motion Picture Camera

VENICE

Operating Instructions

MPC-3610

Firmware Version 1.0



Table of Contents

1. Overview

Features.....	3
System Configuration	5
Location and Function of Parts.....	6

2. Preparation

Preparing a Power Supply	14
Setting the Clock.....	15
Attaching the VF Attachment and Handle.....	16
Mounting a Lens and Adjusting the Flange	
Focal Length	17
Attaching a Viewfinder.....	19
Handling SxS Memory Cards	21
Handling SD Cards for Saving Configuration Data.....	23
Using with AXS-R7	24

3. Camera Operations

Sub Display.....	26
Operations on the Home Screen of the Sub Display	29
User Functions Screen.....	32
Menu Operations	35
Full Menu Operations.....	41
Full Menu List.....	42
Clip Operations.....	52
Playback	54
Operations on the Home Screen of the Mini Display	55

4. Shooting

Basic Operations.....	57
Useful Functions.....	58

5. Connecting External Devices

Connecting External Monitors and Recording	
Devices	59
External Synchronization	61

6. Appendix

Usage Precautions.....	62
Recording Formats and Output Signals	64
Error/Warning Indications.....	68
Items Saved in Files.....	70
Licenses.....	74
Specifications	75

Features

New 36×24 mm Full Frame CMOS Image Sensor

Supports image capture at resolutions up to 6048 × 4032 pixels.* By switching the imager mode, the unit can natively support many shooting formats, including Super 35 24.3 × 12.8 mm, 4096 × 2160 pixel resolution (equivalent to 3-perforation motion picture film) and 4:3 Anamorphic* Super 35 24.3 × 18.3 mm, 4096 × 3024 pixel resolution (equivalent to 4-perforation motion picture film).

* Full Frame and Anamorphic modes require licenses sold separately.

Wide Latitude

The unit supports 15+ stops of latitude. It features very low noise for delivering phenomenal images in conditions from searing sunlight to almost no light, allowing for unprecedented creative freedom in grading.

Wide Color Space Capture

Images can be captured in a color space that exceeds DCI-P3. The degree of freedom in the grading is dramatically improved when using Sony's S-Gamut3.Cine color space together with S-Log3.

PL Lens Mount

Equipped with the industry-standard PL lens mount. The lens mount supports Cooke /i technology, and lens information is recorded as metadata frame by frame.

Compact Body and Intuitive Operation

A relatively compact design for a device equipped with a large Full Frame image sensor, achieved using Sony's miniaturization technology, which allows easier shooting in confined spaces or on drones.

The position, shape, and size of the control buttons reflect the requirements of camera operators for intuitive operation. They also feature backlighting for ease of use in dark locations.

Engineered to Survive

The chassis is made from magnesium alloy for high robustness and durability. The ventilation system is completely isolated from all electronic components to prevent ingress of dust, sand, and liquids.*

The silent-running fan can be cleaned or even swapped out on set quickly and easily to maintain high redundancy.

* Design protects against dust and rain, but cannot completely prevent the ingress of dust and liquid.

Modular design

Features a fully modular design, allowing you to flexibly support various rigs and peripheral equipment according to the shooting application. The top handle and viewfinder are easily adjustable to maintain ergonomic balance and ease of use with lenses. The height of the optical axis is the same as the PMW-F55, permitting the use of peripheral devices used with the PMW-F55. And an optional AXS-R7 Portable Memory Recorder can be securely attached to the rear of the unit using four hex screws.

8-Position Optical ND Filter

Employs an 8-position optical ND filter. It offers a wide ND range of 0.3ND (1/2 = 1 stop) to 2.4ND (1/256 = 8 stops) that reduces time lost on set changing external ND filters. The ND filter mechanism is servo-controlled.

Intuitive and Familiar On-Set Operation

The menu screen is available from both sides of the camera, with the main control display on the Assistant side of the camera for fast access to the camera settings by the camera assistant while shooting.

An OLED mini display on the Operator side allows the operator to access commonly accessed features such as ND filter position, shutter, white balance, and exposure index (EI), making it convenient for the operator to check the status of the unit.

Various Recording Formats

The unit supports recording on SxS memory cards in XAVC and MPEG HD formats. In addition, it can record in 16-bit RAW or X-OCN format onto AXS memory cards when used in combination with an optional AXS-R7 Portable Memory Recorder.

Effective Picture Size

The unit supports shooting in the following effective picture sizes.

[Note]

A software license is required to shoot in 6K 3:2 and 4K 4:3.

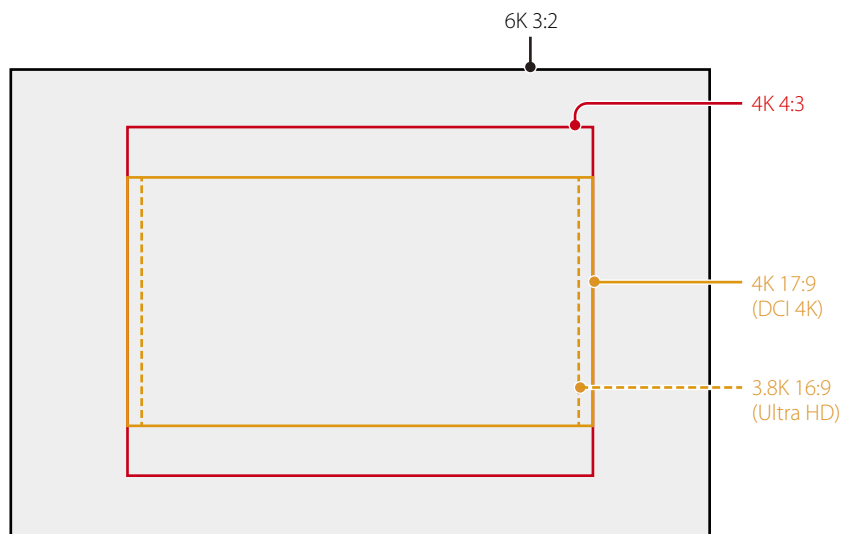

Software Licenses

You can select software licenses (optional) according to the intended usage of the unit. Software licenses are installed using Maintenance > License Options (page 51) in the full menu.

Software license	Imager mode	Effective number of pixels	W × H (mm)	Project frame rate
License not required	3.8K 16:9	3840 × 2160	22.8 × 12.8	23, 24, 25, 29, 50, 59
	4K 17:9	4096 × 2160	24.3 × 12.8	23, 24, 25, 29, 50, 59
Anamorphic License	4K 4:3	4096 × 3024	24.3 × 18.3	23, 24
Full Frame License	6K 3:2	6048 × 4032	35.9 × 24.0	23, 24

[Note]

Recording in 6K 3:2 is supported, but playback is not supported.

System Configuration

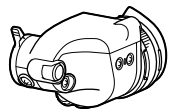

DVF-EL200
Viewfinder

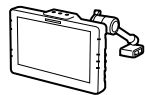

DVF-L700
Viewfinder
(VF cable (A-2201-632-A or
A-2201-633-A) is required)

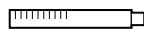

ECM-680S, ECM-678,
ECM-674
Microphone
(EC-0.5X3F5M is required)

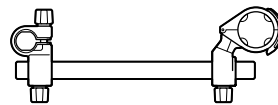

Microphone Holder (A-2182-620-A)
Rod Clamp (A-2182-621-A)
Rod (4-684-612-01)

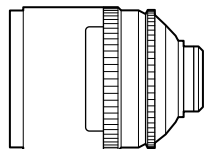

SCL-PK6,
SCL-P11X15
S35 PL Lens



CBKZ-3610A,
CBKZ-3610AM,
CBKZ-3610AW
Anamorphic
License

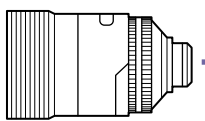

Anamorphic Lens



CBKZ-3610F,
CBKZ-3610FM,
CBKZ-3610FW
Full Frame License

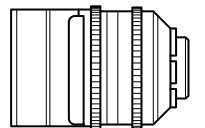

Full Frame Lens

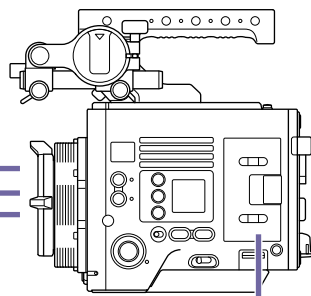

MPC-3610

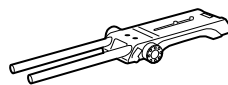

VCT-FSA5
Shoulder Adaptor

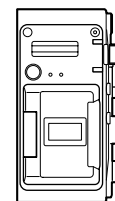

AXS-R7
Portable Memory
Recorder

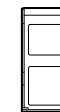

AXS-A256S24, AXS-A512S48,
AXS-A512S24, AXS-A1TS48,
AXS-A1TS24
AXS Memory Card

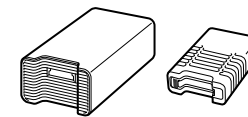

AXS-AR1, AXS-CR1
AXS Memory Card
Reader

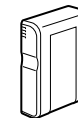

BP-FL75, BP-FLX75
Battery Pack

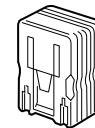

AC-DN2B, AC-DN10
AC Adaptor

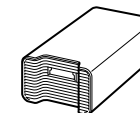

AXS-AR1
AXS Memory Card Reader



SBAC-US30/UT100
USB Card Reader

SBP-256D, SBP-128B/C/D, SBP-64A/B/C/D, SBP-32,
SBS-64G1A/B, SBS-32G1A/B
SxS Memory Card

QD-S64E, QD-S32E, QD-N64, QD-M128A, QD-M64A,
QD-M32A, QD-G128A/E, QD-G64A/E, QD-G32A/E
XQD Memory Card
(QDA-EX1 XQD ExpressCard Adaptor is required)

Location and Function of Parts

Operator Side

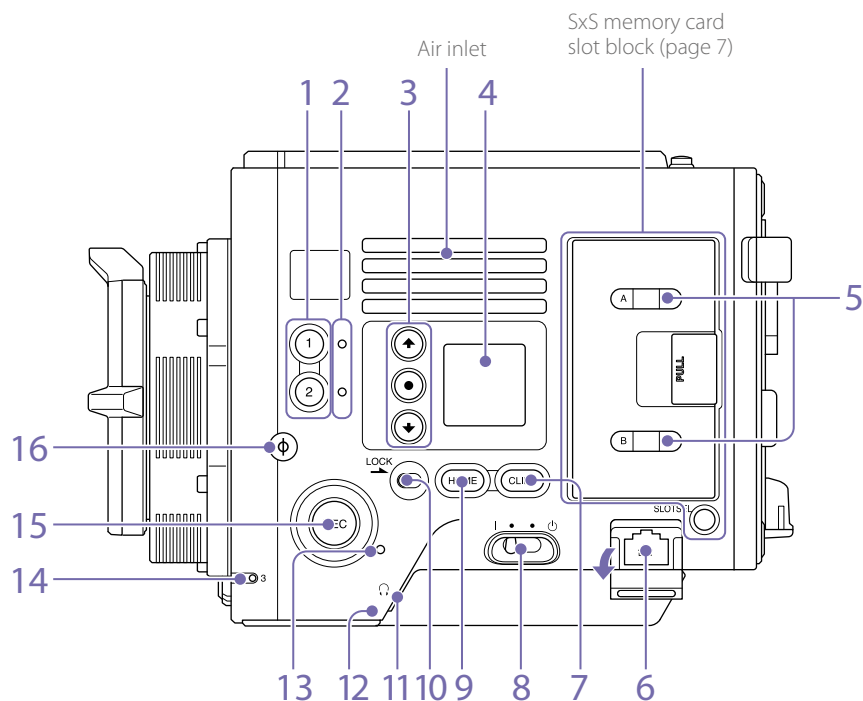

1. **ASSIGN (assignable) buttons 1/2 (page 32)**
Assign functions using the EDIT page of the user functions screen (page 32). The assigned function toggles between on/off (enable/disable) or is activated with each press.
2. **ASSIGN (assignable) lamps 1/2 (page 32)**
Each lamp is lit orange when the assigned function is on (enabled) or activated, and not lit when the function is off (disabled).
3. **Mini display ITEM keys 1 to 3**
Controls the operation of functions on the mini display (page 55).

4. **Mini display**
Displays various setup items, such as shutter angle, that you can check or modify (page 55).
5. **ACCESS lamps (SLOT A/B)**
Each lamp is lit when the recording media in SxS card slot A/B is the target for recording/playback and when data is being written to or read from the recording media in SxS card slot A/B (page 21).
6. **Network connector (RJ-45)**
Not supported in firmware version 1.0.
7. **CLIPS button**
Not supported in firmware version 1.0.

8. **Power switch**
Set to the ON position (I) to turn the power on. Set to the OFF position (⏻) to turn the power off.
[CAUTION]
 - This unit uses a small amount of standby power even when the power switch is set to OFF. Remove the battery pack if the unit will not be used for a prolonged period.
 - When removing the battery pack or the DC IN power, be sure to first set the power switch to the OFF position. Interrupting the power supply during recording or during memory card access could cause a malfunction.
9. **HOME button**
Press to clear the item selection display and return to the Home screen on the mini display. If pressed when the unit is in playback state, the unit transitions to shooting mode (page 55).

10. **LOCK switch**
Locks the operation of the buttons on the Operator side. When locked, the switch background LED lights in orange.
11. **Headphones connector (stereo mini jack)**
Connect to earphones for audio monitoring. You can monitor the input audio during shooting/recording and playback sound during playback (page 54).

12. **Built-in speaker**
You can monitor the input audio during shooting/recording and playback sound during playback. The speaker also sounds alarms to reinforce visual warnings (page 54).
If you connect earphones to the headphones jack, the speaker output is suppressed automatically.
13. **REC ACTIVE lamp**
The lamp is lit green when the REC button is enabled.

14. **ASSIGN (assignable) lamp 3 (page 32)**
The lamp is lit orange when the assigned function is on (enabled) or activated, and not lit when the function is off (disabled).
15. **REC (recording start/stop) button/lamp**
Press to start recording, turning the REC lamp on. Press again to stop recording, turning the REC lamp off (page 57).
The REC lamp flashes when a device error or warning occurs.
16. **φ mark**
The φ mark is on the same plane as the image sensor.
To measure the precise distance between the unit and the subject, use the φ mark as a reference.

SxS memory card slot block (page 21)

The SxS memory card slots are located behind the cover.

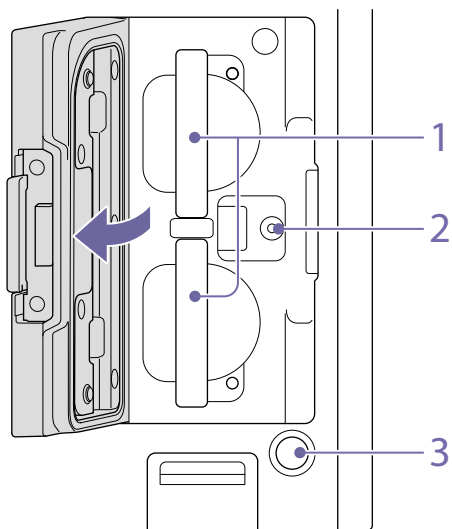

1. **SxS memory card slots A/B**
2. **Manufacturer calibration terminal**
Manufacturer terminal for calibration and servicing (cannot be used by users).
3. **SLOT SELECT (SxS memory card select) button**
Press to switch the active slot.

Assistant Side

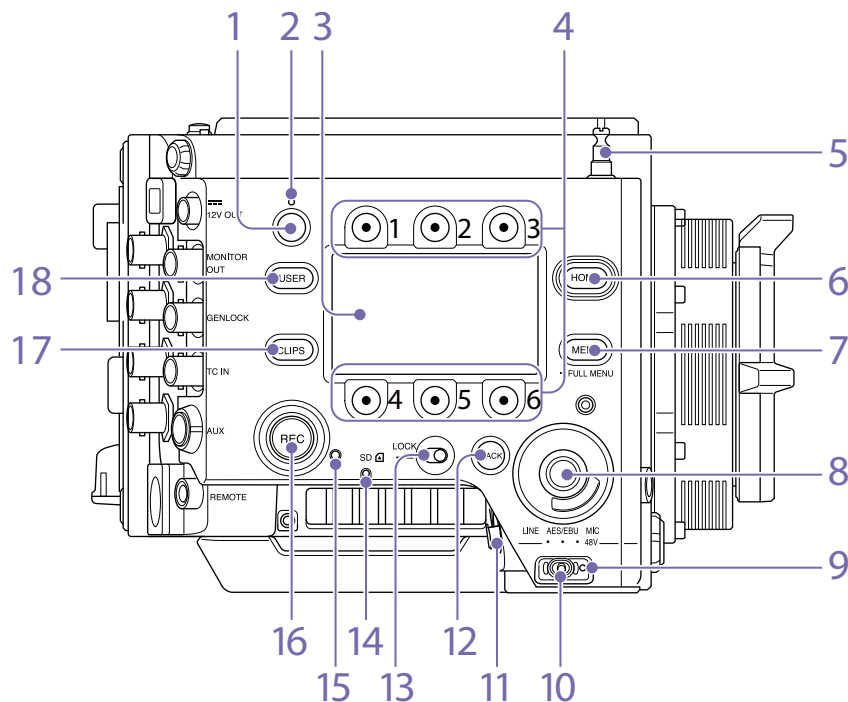

1. **ASSIGN (assignable) button 4 (page 32)**
Assign functions using the EDIT page of the user functions screen (page 32). The assigned function toggles between on/off (enable/disable) or is activated with each press.
2. **ASSIGN (assignable) lamp 4 (page 32)**
The lamp is lit orange when the assigned function is on (enabled) or activated, and not lit when the function is off (disabled).
3. **Sub display**
Allows you to check the operation status of the unit and make various settings (page 27).
4. **Sub display ITEM keys 1 to 6**
Controls the operation of functions on the sub display (page 35).
5. **Tape measure hook**
The tape measure hook is on the same plane as the image sensor. To measure the precise distance between the unit and the subject, use

the tape measure hook as a reference. You can attach the end of a tape measure to the hook, and measure the distance from the subject.

6. **HOME button**
Press to clear the display and return to the Home screen on the sub display (page 29). If pressed when the unit is in playback state, the unit transitions to shooting mode.
7. **MENU (menu display on/off) button (pages 35, 41)**
Press the MENU button to display the menu screen on the sub display. Press and hold the MENU button for 2 seconds or longer to display the full menu screen on the sub display. Press the button during menu screen or full menu screen display to return to the previous screen display.
8. **SEL/SET (select/set) dial (MENU dial)**
Changes the item selection or a setting within the menu (pages 29, 35, 41).
9. **+48V power lamp**
Lights in green if the AUDIO IN switch is set to MIC and +48 V phantom power is supplied on the AUDIO IN connector. It is not lit if phantom power is not supplied.
You can turn +48 V phantom power on/off using Audio category > Audio Details > Audio Configuration > Phantom Power +48V (page 48) in the menu.
10. **AUDIO IN (audio selector) switch**
Select the input signal type corresponding to the audio source connected to the AUDIO IN connector.
LINE: When connecting an external analog audio signal source
AES/EBU: When connecting an external digital audio signal source
MIC: When connecting a microphone.

11. AUDIO IN connector (XLR 5-pin)

Input external microphone or audio equipment signals.

When the audio source is set to LINE or MIC using the AUDIO IN switch, this connector functions as the AUDIO IN CH-1 and AUDIO IN CH-2 connector.

When the audio source is set to AES/EBU using the AUDIO IN switch, this connector functions as an AUDIO IN CH-3/4 connector.

12. BACK button

Cancels the menu setting and moves up one level in the menu hierarchy during menu display. Cancels the execution process or pending process during process execution/pending display (pages 29, 35, 41).

13. LOCK switch

Locks the operation of the buttons on the Assistant side. When locked, the switch background LED lights in orange.

14. ACCESS (SD card access) lamp (page 23)**15. REC ACTIVE lamp**

The lamp is lit green when the REC button is enabled.

16. REC (recording start/stop) button/lamp

Press to start recording, turning the REC lamp on. Press again to stop recording, turning the REC lamp off (page 57).

The REC lamp flashes when a device error or warning occurs.

17. CLIPS button

Press to display the clip list screen on the sub display to enable clip operations (page 52). To switch from playback mode to shooting mode, press the HOME button.

18. USER button

Press to display the user function list on the sub display, and to operate the ITEM keys 1 to 5 user function buttons.

ITEM key 6 is the user function list EDIT button. Press this button to display the function selection screen for the user function buttons and assignable buttons. Press again when the user functions screen is displayed to return to the previous display (page 32).

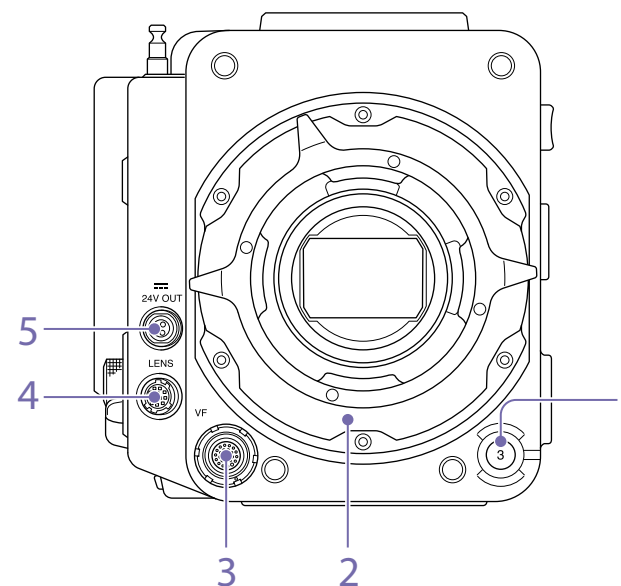
Front**1. ASSIGN (assignable) button 3 (page 32)**

Assign functions using the EDIT page of the user functions screen (page 32). The assigned function toggles between on/off (enable/disable) or is activated with each press.

2. PL lens mount adaptor (page 17)**3. VF (viewfinder output) connector (page 19)**

Not supported in firmware version 1.0.

4. LENS connector (12-pin)

Not supported in firmware version 1.0.

5. 24V OUT connector (DC OUT 24 V, Fischer 3-pin)

24 V DC power supply output connector (page 59). The output voltage and maximum output current of this connector vary depending on the input voltage to the unit. The maximum current includes the output current from the 24V OUT connector on the rear panel (page 9).

11 V to 17 V input

Output voltage : 24 V
Maximum output current: 1.0 A

22 V to 32 V input

Output voltage: Same as the input voltage
Maximum output current: 2.0 A

Rear

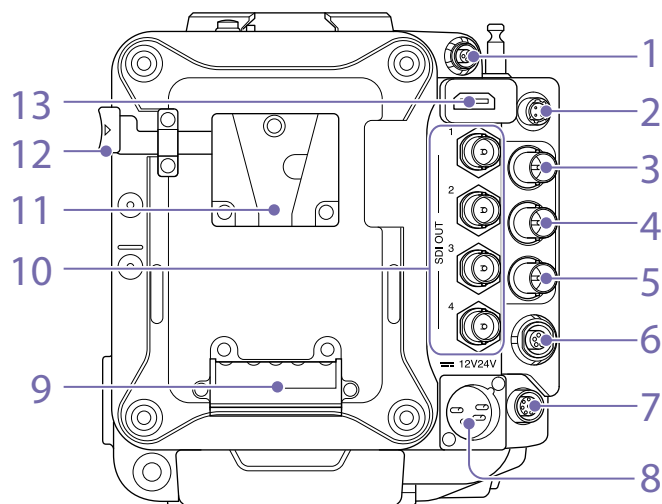

1. 24V OUT connector (DC OUT 24 V, Fischer 3-pin)

24 V DC power supply output connector (page 59).

The output voltage and maximum output current of this connector vary depending on the input voltage to the unit. The maximum current includes the output current from the 24V OUT connector on the front panel (page 8).

11 V to 17 V input

Output voltage : 24 V

Maximum output current: 1.0 A

22 V to 32 V input

Output voltage: Same as the input voltage
Maximum output current: 2.0 A

2. 12V OUT connector (DC OUT 12V, Hirose 4-pin)

12V DC power supply output connector (page 59).

The output voltage and maximum output current of this connector vary depending on the input voltage to the unit.

11 V to 17 V input

Output voltage: Same as the input voltage
Maximum output current: 1.0 A

22 V to 32 V input

Output voltage : 15 V
Maximum output current: 0.8 A

3. MONITOR OUT connector (BNC type)

HD SDI monitor signal output connector (page 59).

4. GENLOCK (genlock input) connector (BNC type)

To genlock the unit to an external source or to lock the timecode of the unit to an external source, input an external reference signal.

Digital signal and analog signal input are supported.

Digital signal: 1.5G HDSDI interlaced signal

Analog signal: HD sync, Analog

5. TC IN (timecode input) connector (BNC type)

To lock the timecode of the unit to an external source, input a reference timecode signal.

6. AUX connector (LEMO 5-pin)

Outputs the timecode signal (page 60).

7. REMOTE (remote control) connector (8-pin)

Not supported in firmware version 1.0.

8. 12V/24V (DC power input) connector (page 14)

DC power supply input connector for external power supply to the unit. Supports 12 V and 24 V input voltages.

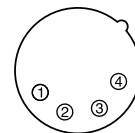

No.	Signal
1	GND
2	NC
3	NC
4	DC IN (11 V to 17 V or 22 V to 32 V)

9. Battery attachment terminal (page 14)

10. SDI OUT 1 to 4 (serial digital output) connectors (BNC type) (page 59)

11. Battery pack mount (page 14)

12. Battery release lever (page 14)

13. HDMI OUT connector (page 59)

Top

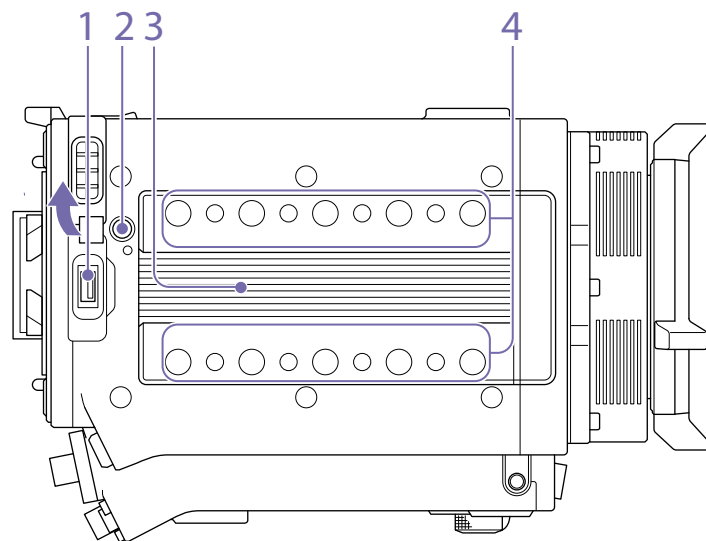

1. **External device connector**
Not supported in firmware version 1.0.
2. **Release button** (page 16)
3. **Handle/VF attachment mount** (page 16)
4. **Accessory mounting screw holes**
Type of screw: 1/4-20UNC (8)
Type of screw: 3/8-16UNC (10)
Length of engagement: 10 mm (3/8 inch) or less

Bottom

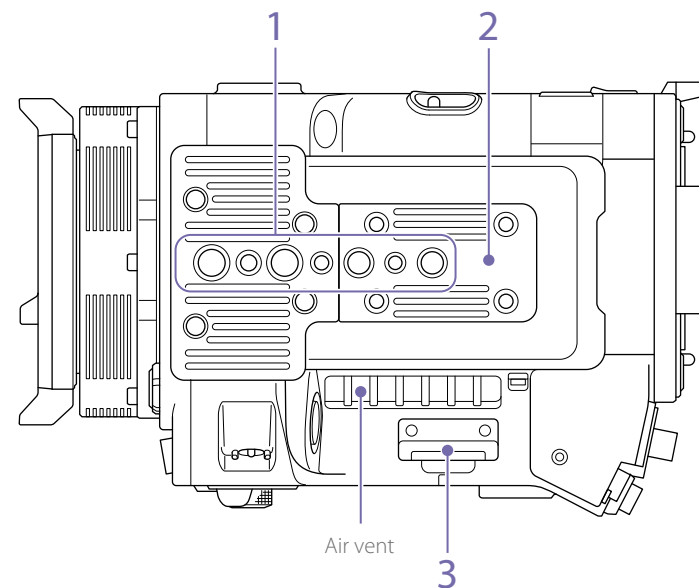

1. **Tripod plate attachment holes**
Type of screw: 1/4-20UNC (2)
Type of screw: 3/8-16UNC (4)
Length of engagement: 9 mm (3/8 inch) or less
2. **Bottom cover**
Remove the four hex screws to remove the cover.
3. **SD card slot** (page 23)

Viewfinder Screen

During shooting (recording or standby) and playback, the status and settings of the unit are superimposed over the picture on the viewfinder screen.

Information displayed on the screen while recording



1. **Recording frame rate indicator**
Displays the recording frame rate and project frame rate.
1.8: 1/64
2.1: 1/128
2.4: 1/256
2. **Shutter angle/shutter speed indicator**
Displays the shutter angle or shutter speed of the electronic shutter.
3. **ND filter indicator**
Displays the density of the ND filter. The display value is a LOG (base 10) value (page 42).
0.3: 1/2
0.6: 1/4
0.9: 1/8
1.2: 1/16
1.5: 1/32
4. **Thermometer icon**
Displayed when a high temperature warning message is issued. The description is displayed in the Info category in the menu.
5. **Warning icon**
Displayed when other than a high temperature warning message is issued. The description is displayed in the Info category in the menu.

6. **Exposure index indicator**
Displays the exposure index (EI) value.
7. **Color temperature indicator**
Displays the color temperature and Tint value of the white balance.
8. **Look information display**
Displays the selected Look (page 43).
9. **Battery capacity/voltage indicator**
Displays the following indicators according to the type of battery power source.
16. **Monitor LUT indicator**
Displays the LUT setting of the Monitor output (page 42).
17. **HDMI LUT indicator**
Displays the LUT setting of the HDMI output (page 42).

Battery type	Display
InfoLithium battery	Battery remaining capacity and remaining recording time
Anton/Bauer battery	Remaining battery capacity (% indicator)
Other batteries	Input voltage

10. **VF LUT indicator**
Displays the viewfinder LUT (page 42).
11. **VF Double Speed Scan indicator**
Displays the on/off state of the function for doubling the frame rate of the viewfinder display.
12. **VF Peaking indicator**
Displays the on/off state of the peaking function of the viewfinder display.
13. **VF Zebra indicator**
Displays the on/off state of the zebra function of the viewfinder display (page 33).
14. **SDI OUT 1/2 connector LUT indicator**
Displays the LUT setting of the SDI OUT 1/2 connectors (page 42).
15. **SDI OUT 3/4 connector LUT indicator**
Displays the LUT setting of the SDI OUT 3/4 connectors (page 42).

18. SDI output REC trigger indicator

Displays the SDI output REC trigger status.

State	Display	
Technical > System Configuration > SDI Rec Remote Trigger in the full menu	Recording command superimposed on the SDI output	
Off	–	(Blank)
HD SDI Remote I/F	Stop command	Top: SDI Bottom: Stop
	Rec command	Top: SDI Bottom: REC
Parallel Rec	Stop command	Top: SDI-P Bottom: Stop
	Rec command	Top: SDI-P Bottom: REC

19. Audio level meter indicators

Displays the levels of audio channels 1 and 2 while recording.

20. Recording media state/remaining capacity indicator for each media slot

Displays the state and remaining capacity of the media in SxS memory card slots A/B and AXS memory card slots A/B.

A  mark on the left of "AXS" or "SxS" indicates the recording target media.

An indicator  on the upper right of the slot A/B icon on the right of "AXS" or "SxS" indicates the playback target media (green indicator indicates media is being played).



A  icon is displayed for media if a condition occurs that could impact recording.

21. Recording media format (codec) indicator

Displays the format of the recording on an AXS memory card or an SxS memory card.

22. Recording status indicator

Displays the following recording operation states of the unit.

Display	Description
	During recording
	Recording standby

23. Clip name display

Displays the first 8 characters of the name of the next clip to be recorded in recording standby mode.

Displays the first 8 characters of the name of the clip currently being recorded when recording.

24. Time data display

Displays the duration or timecode, depending on the TC/Media category > TC Display setting in the menu (page 36).

25. Iris position indicator

Displays the iris position (only when a lens that is compatible with the iris setting display function is attached).

26. Focus position indicator

Displays the focus position (only when a lens that is compatible with the focus setting display function is attached).

27. Zoom position indicator

Displays the focal length of the zoom (displayed only when a lens that supports the zoom setting indicator is attached).

28. Simultaneous recording status indicator

Displays the sub clip recording format in 1-slot simultaneous recording mode (page 58).

29. SxS Sub LUT indicator

Displays the LUT setting to register for a sub clip in SxS 1-slot simultaneous recording mode.

30. SxS LUT indicator

Displays the LUT setting for SxS recording.

31. Effective picture size indicator

Displays the effective picture size and whether anamorphic de-squeeze conversion is applied, set using Project category > Imager Mode in the menu (page 36).

Information displayed on the playback screen

The following information is displayed on the playback picture.

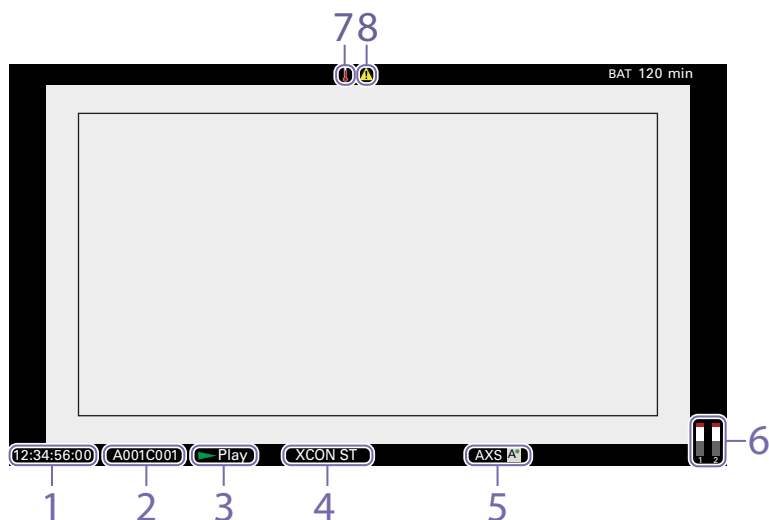

1. **Time data display**
Displays the duration or timecode, depending on the TC/Media category > TC Display setting in the menu (page 36).
2. **Playback clip name display**
Displays the first 8 characters of the name of the playback clip.
3. **Playback status indicator**
Displays the playback status.
4. **Playback media format (codec) indicator**
Displays the recording format (codec) of the playback clip.
5. **Playback media indicator**
Displays the type of recording media being played.
A  icon appears on the right if the memory card is write-protected.
6. **Audio level meter indicators**
Displays the levels of audio channels 1 and 2 during playback.
7. **Thermometer icon**
Displayed when a high temperature warning message is issued.
The description is displayed in the Info category in the menu.
8. **Warning icon**
Displayed when other than a high temperature warning message is issued.
The description is displayed in the Info category in the menu.

Preparing a Power Supply

You can use a battery pack or AC power via an AC adaptor.

For safety, use only the Sony battery packs and AC adaptors listed below.

Lithium-ion battery pack

BP-FL75

BP-FLX75

AC adaptor

AC-DN2B

AC-DN10

Using a Battery Pack

Insert the battery pack into the battery pack mount (page 9) of the battery adaptor, then slide the battery pack down to lock it in place. To remove it, unlock the battery pack by sliding it up while pressing the battery release lever (page 9), then remove it.

[Notes]

- Before use, charge the battery pack with the battery charger.
- A warm battery pack immediately after use may not be able to be fully recharged.
- Remove the battery adaptor while supporting the unit by hand.

Checking the remaining battery charge

When recording or playback is in progress using the battery pack, an icon to show the current battery remaining time and battery voltage are displayed on the sub display screen (page 27) and viewfinder screen (page 11).

The unit indicates the remaining usage time in minutes by calculating the available time with the battery pack if operation is continued at the current rate of power consumption.

If the remaining battery charge becomes low

If the remaining battery charge decreases to a certain level during operation, the remaining battery capacity indicator flashes and the REC lamp flashes to warn you.

If the remaining charge further decreases to a level at which operation cannot be continued, a battery-empty message appears.

Replace the battery pack with one that is fully charged.

To change the message levels

Change levels using Technical > Battery (page 49) in the full menu.

Using AC Power (DC IN Power)

The unit works with AC power using the AC-DN10 (optional) or AC-DN2B AC adaptor (optional) and CCDD-X2 DC cable (optional).

11 V to 17 V and 22 V to 32 V input voltage ranges are supported.

[Note]

When switching to the DC IN power supply during battery operation, use a power supply with a voltage in the range 12 V to 17 V or 22 V to 32 V.

Setting the Clock

When you use the unit for the first time, the initial setup screen appears on the sub display when the power is turned on.

Set the date and time of the built-in clock using this display.

Time Zone

The value shows the time difference from UTC (Coordinated Universal Time). Change the setting if needed.

[Note]

When Time Zone is changed, the clock setting changes according to the time difference.

Setting the Date and Time

Turn the MENU dial (page 7) to move the cursor, then press the MENU dial to set each menu item. When you press the MENU dial when the cursor is on "Set," the setting display disappears and the clock setting is completed.

After the initial setup screen disappears, you can change Time Zone and date/time settings using Maintenance > Clock Set (page 50) in the full menu.

[Notes]

- If the clock setting is cleared because the backup battery fully discharged when no power was supplied (no battery pack and no DC IN connection), the initial setup display will be displayed when you next turn the unit on.
- While the initial setup display is shown, no other operation, except turning the power off, is permitted until you finish the setting for this display.

Attaching the VF Attachment and Handle

Attaching the VF Attachment

- 1 Slide the VF attachment on in the direction of the arrow to attach it.
- 2 Position the VF attachment in the desired front/rear position, then turn the lock lever to secure it in position.

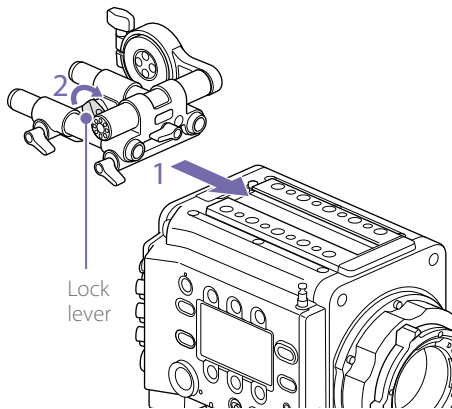

[Note]

You can also attach the VF attachment in the front/rear or left/right orientation.

To remove the VF attachment

Turn the lock lever to loosen, press the release button and slide the VF attachment off in the reverse direction from when attaching it.

Attaching the Handle

- 1 Slide the handle on in the direction of the arrow to attach it.
- 2 Position the handle in the desired front/rear position, then turn the lock lever to secure it in position.

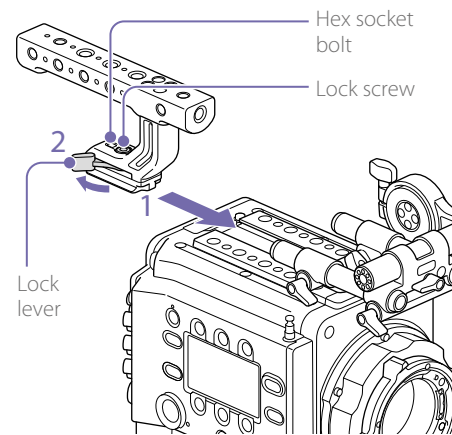

[Notes]

- You can also attach a lock screw using a hex wrench (5 mm) to secure it in position.
- If the lock lever on the handle becomes loose during use, you can secure the handle by tightening a hex socket bolt (2 mm) beside the lock screw.
- You can also attach the handle in the reverse orientation.

To remove the handle

Turn the lock lever to loosen, press the release button and slide the handle off in the reverse direction from when attaching it.

Mounting a Lens and Adjusting the Flange Focal Length

Recommended lens (Super 35mm size)

SCL-PK6/F, SCL-PK6/M (set of 6 lenses, 20 mm/25 mm/35 mm/50 mm/85 mm/135 mm)

SCL-PK3/F, SCL-PK3/M (set of 3 lenses, 20 mm/25 mm/135 mm)

SCL-P11X15

For details about available lenses for the unit, contact a Sony service representative.

[CAUTION]

Do not leave the lens facing the sun. Direct sunlight can enter through the lens, be focused in the unit, and cause fire.

[Notes]

- A lens is a precision part. Do not place the lens down with the mount side facing down. Attach the cap supplied with the lens.
- The lens interface of the unit is configured by factory default for an SCL-P11X15 and lenses with Cooke type connector. To use an SCL-PK6, SCL-PK3, or other lenses that do not have a Cooke type connector, set Technical > System Configuration > Lens Interface (page 49) to Off in the full menu. If this setting is not correct, an alert message appears when the unit is turned on after attaching the lens.

Attaching a PL Mount Lens

- 1 Remove the mount cover from the lens mount by turning the PL mount lever counterclockwise.

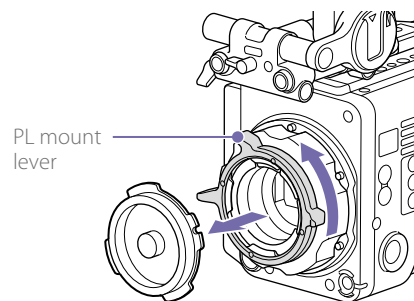

[Note]

Turn the PL mount lever counterclockwise to the stopper position.

- 2 Insert the lens into the lens mount by aligning the concave part of the lens with the positioning pin on the upper right of the lens mount.

- 3 Secure the lens by turning the PL mount lever clockwise while holding the lens.

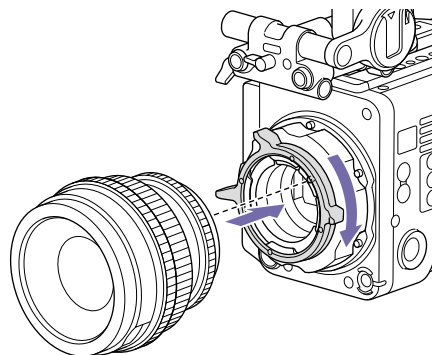

[Note]

Do not turn the lens when attaching the PL mount lens. It may cause damage to the hot shoe pin.

To attach a Cooke /i lens

Align the contacts on the lens with the hot shoe of the unit. There are two connectors on the side of the lens adaptor, and either can be used.

To remove the lens

- 1 Turn the PL mount lever counterclockwise while holding the lens from underneath.
- 2 Pull the lens forward.

[Notes]

- If another lens will not be attached soon, carefully align the concave part of the mount cover, then secure the mount cover by turning the PL mount lever clockwise.
- In firmware version 1.0, images will not be output normally if the PL mount adaptor is removed.

Adjusting the Flange Focal Length

The unit is shipped with the flange focal length already adjusted. If you need to adjust the flange focal length, remove the lens mount, and change the shims with those of the appropriate thickness. You can adjust the thickness by ± 0.1 mm in 0.01 mm increments.

Shims

The following shims are supplied with the unit.

0.05 mm \times 1 (circular)

0.01 mm \times 15 (1/3 arc)

1/3 arc shims should always be used as a set of three shims. Insert shims to increase the flange focal length. The unit is shipped with the flange focal length already adjusted using the following three types of shims.

0.10 mm (circular)

0.05 mm (circular)

0.01 mm (1/3 arc)

A seal is attached showing the shim thickness when shipped.

Adjusting the flange focal length

- 1 Remove the six Torx screws and remove the PL mount flange.

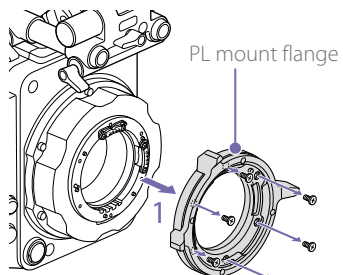

- 2 Loosen the four Phillips screws on both sides of the PL connectors (two locations), and remove the PL connectors and PL connector plates.

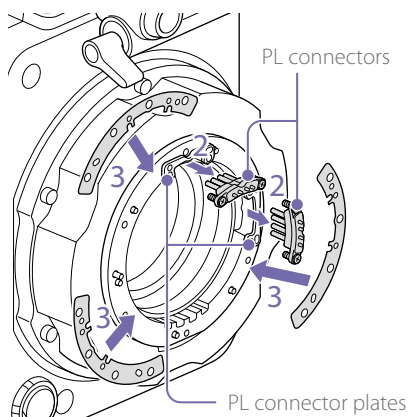

- 3 Attach shims to the PL mount adaptor (three locations).

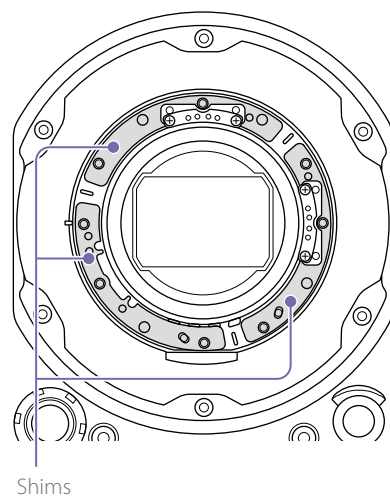

When using circular shims

Attach with the surface that has markings on it facing the front.

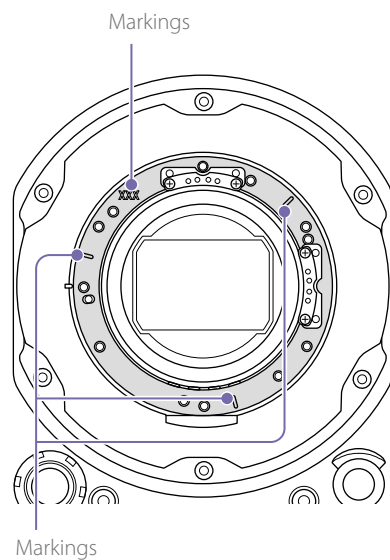

When using 1/3 arc shims

Attach shims that have the same thickness in all three locations.

- 4 Reattach the PC connectors (two locations) to their original positions, and tighten the four Phillips screws with 0.18 N-m tightening torque.
- 5 Reattach the PL mount flange in its original position, and tighten the six Torx screws to a tightening torque of 0.35 N-m using a T8 torque wrench.

Cleaning the Filter

To clean the filter, first remove the adaptor. Exercise care when wiping the adaptor center part (shaded part) with a cloth or other material to prevent fibers adhering to surfaces. If fibers are adhering, wipe off using a soft brush.

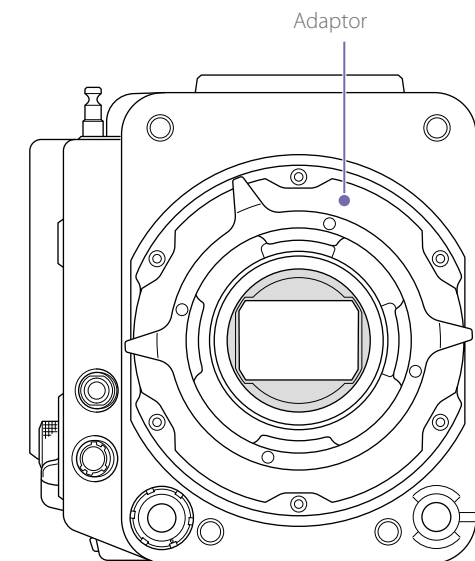

Attaching a Viewfinder

Available viewfinders for the unit

DVF-EL200: OLED color viewfinder

DVF-L700: LCD color viewfinder

Viewfinders are available separately.

This section describes attachment of the DVF-EL200 as an example.

For details about attaching each viewfinder, refer to the operating instructions of the viewfinder.

[CAUTION]

Do not leave the unit with the eyepiece of the viewfinder facing the sun. Direct sunlight can enter through the eyepiece, be focused in the viewfinder, and cause fire.

[Notes]

- Attach/remove the viewfinder while the unit is turned off.
- A VF cable (A-2201-632 or A-2201-633-A) is required in order to attach the DVF-L700. Also, turn the unit on after setting the POWER switch of the DVF-L700 to the ON position.

Attaching a Viewfinder

- 1 Align the viewfinder shoe with the groove of the viewfinder mount on the VF attachment, and attach the viewfinder.
- 2 Turn the viewfinder lock lever in the LOCK direction to secure it in position.

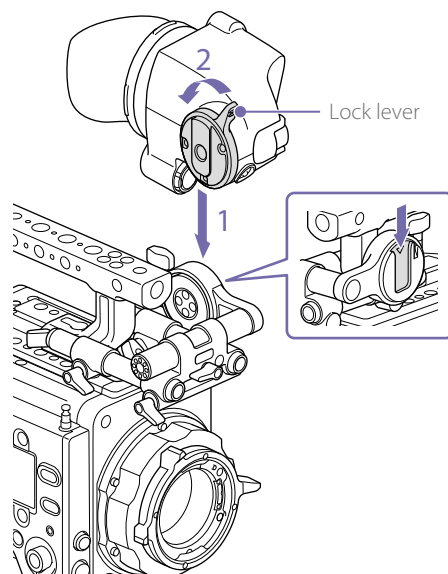

- 3 Connect the viewfinder and unit using the VF connection cable.
Viewfinder side:
Position the connector with the mark (red) at the top, and fully insert the connector.
Camera side:
Align the concave part of the VF connector with the connector mark (red), and fully insert the connector.

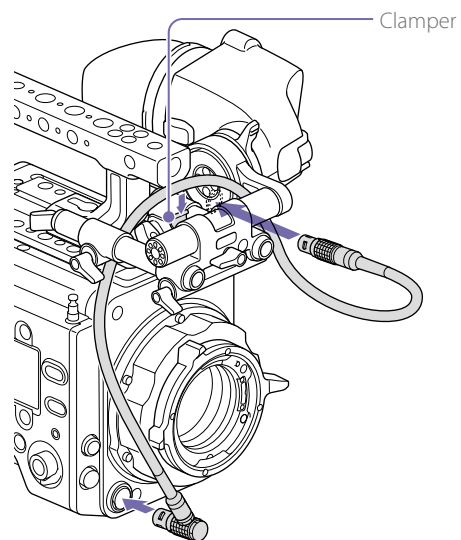

[Note]

Secure the cable in the clammer as required.

To remove the viewfinder

- 1 Disconnect the VF connection cable from the viewfinder and unit.
- 2 Turn the lock lever in the direction opposite to LOCK, then remove the viewfinder from the VF attachment.

Adjusting the Viewfinder Position

To adjust the front/rear position

- 1 Loosen one or both of the front/rear rod lock levers of the VF attachment.
- 2 Slide the VF attachment forward/rearward to adjust the viewfinder position.

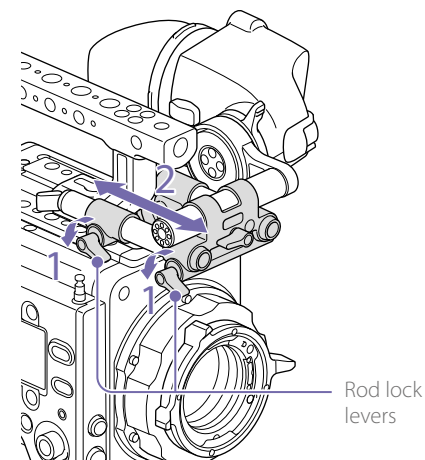

- 3 Tighten the rod lock levers.

[Note]

If a rod lock lever is difficult to turn, pull the lever out, turn it to a position where it is easier to operate, and then push the lever back in.

To adjust the left/right position and height (angle)

- 1 Loosen the rod lock lever at the front of the VF attachment.
- 2 Slide the VF attachment rod left/right and turn the rod up/down to adjust the viewfinder position.

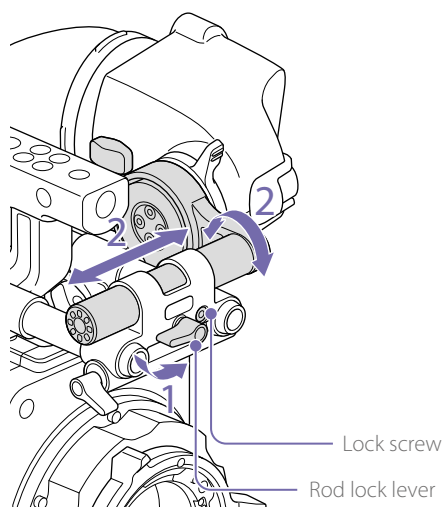

- 3 Tighten the rod lock lever.

[Note]

When the rod lock lever is loosened, adjust the lock screw using a hex wrench (3 mm) to prevent the viewfinder from falling down.

To adjust the viewfinder angle

You can adjust the angle of the viewfinder while shooting.

- 1 Loosen the rotation lock lever on the viewfinder mount.
- 2 Turn the viewfinder up/down to adjust the angle.

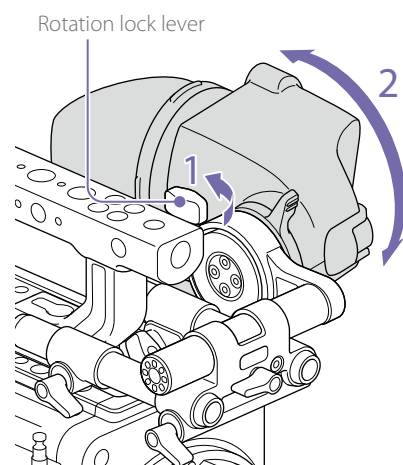

- 3 Tighten the rotation lock lever.

Handling SxS Memory Cards

This unit records audio and video on SxS memory cards (optional) loaded in the card slots.

About SxS Memory Cards

Use the following Sony SxS memory cards or XQD memory cards.*

* When using an XQD memory card, the XQD ExpressCard adaptor (QDA-EX1) is required.

The supported memory cards differ depending on the recording format.

SxS PRO+

SBP-256D, SBP-128B/C/D, SBP-64B/C/D: Supported for all recording formats.

SxS PRO

SBP-64A, SBP-32:
MPEG 1920×1080P/i

SxS-1

SBS-64G1A/B, SBS-32G1A/B:
MPEG 1920×1080P/i

XQD memory card S series, G series

QD-S64E, QD-S32E, QD-G128A/E, QDG64A/E, QD-G32A/E: Supported for all recording formats.

XQD memory card N series, M series

QD-N64, QD-M128A, QD-M64A, QD-M32A:
MPEG 1920×1080P/i

Operations are not guaranteed with other memory cards.

These memory cards comply with the ExpressCard standard.

For details on using SxS memory cards and usage-related precautions, refer to the instruction manual for the SxS memory card.

- SxS, SxS PRO, and SxS-1 are trademarks of Sony Corporation.
- XQD is a trademark of Sony Corporation.
- The ExpressCard word mark and logo are owned by Personal Computer Memory Card International Association (PCMCIA) and are licensed to Sony Corporation. All other trademarks are the property of their respective owners.

Inserting an SxS Memory Card

- 1 Open the cover of the card slot block (page 7).
- 2 Insert the SxS memory card into the slot with the SxS label facing to the right. The ACCESS lamp (page 6) lights in red then changes to green once the memory card is ready for use.
- 3 Close the cover.

ACCESS lamp status

Card slots A and B each have an ACCESS lamp that indicate the slot status.

Lamp	Slot status
Lights in red	Accessing the SxS memory card (writing/reading data)
Lights in green	Standby (ready for recording or playback using the SxS memory card)
Off	<ul style="list-style-type: none"> • No SxS memory card is loaded. • The loaded card is invalid. • An SxS memory card is loaded, but the other slot is selected.

Removing an SxS Memory Card

- 1 Open the cover of the card slot block .
- 2 Pull out the SxS memory card.

[Note]

Data integrity is not guaranteed if the power is turned off or a memory card is removed while it is being accessed. Data on the card may be destroyed. Be sure that its ACCESS lamp is lit in green or off when you turn off the power or remove a memory card.

Switching Between SxS Memory Cards

When SxS memory cards are loaded in both slot A and slot B, you can press the SLOT SELECT button (page 7) to select the SxS memory card to use. If a card becomes full, recording continues after automatically switching to the second card.

[Note]

The SLOT SELECT button is disabled while recording/playback is in progress. The memory cards are not switched even if you press the button.

Formatting (Initializing) SxS Memory Cards

When an unformatted SxS memory card or an SxS memory card formatted in another specification is loaded, a message notifying you that the media has a different file system appears. In this case, format the memory card in the following way.

- 1 Select TC/Media category > Format Media in the menu.
- 2 Select SxS Slot A (slot A) or SxS Slot B (slot B), then press the MENU dial.
A confirmation screen prompting whether to format the card appears.
- 3 Press and hold ITEM key 1 and ITEM key 3 for 3 seconds to execute formatting.
Formatting starts, a message is displayed during execution, and the ACCESS lamp lights in red.
When formatting ends, a completion message appears. Press the MENU dial to dismiss the message.

If formatting fails

A write-protected SxS memory card or memory card that cannot be used with this unit will not be formatted.

A warning message is displayed. Replace the card with an appropriate SxS memory card, according to the instructions in the message.

[Note]

All the data, including recorded pictures and setup files, are erased when a memory card is formatted.

Formatting while recording

Even while recording, the SxS memory card loaded in the other card slot can be formatted.

Checking the Remaining Recording Time

While shooting (recording or standby), you can check the remaining capacity on the SxS memory cards loaded in each slot using the recording media remaining capacity indicator on the Home screen of the sub display (page 27) or the viewfinder screen (page 11).

The available time for recording with the current video format (recording bit rate) is calculated according to the remaining space on each card and displayed in time units of minutes.

[Note]

A  icon appears if a memory card is write-protected.

Exchanging an SxS memory card

- If the total remaining time on the inserted memory cards during recording becomes less than 5 minutes, the remaining media capacity indicator flashes, the REC lamp flashes, and a beep sound is emitted to warn you. Replace the cards with those that have sufficient space.
- If you continue recording, the message “Media Full” appears, and recording stops when the total remaining recording time falls to 0.

[Note]

Up to approximately 600 clips can be recorded on one SxS memory card.

The display of remaining recording time changes to “0” and the message “Media Full” appears when the clip limit is reached.

Restoring an SxS Memory Card

If for any reason an error should occur in a memory card, the card must be restored before use.

If an SxS memory card that needs to be restored is loaded, a message prompting you to execute the restore operation is displayed on the sub display.

To start the restore process, select Execute by turning the MENU dial, then press the MENU dial.

The restoration starts.

During execution, a message is displayed and the ACCESS lamp lights in red.

When restoration ends, a completion message appears. Press the MENU dial to dismiss the message.

If restoration fails

- A write-protected SxS memory card, or one on which an error occurred, cannot be restored. For such a card, a warning message is displayed. Release the write protection or replace the card, according to the instructions in the message.
- An SxS memory card on which an error occurred may become usable again when reformatted.
- In some cases, some clips can be restored while others cannot. Playback of the restored clips becomes possible again.
- The following operation may restore an SxS memory card for which the message “Could not Restore Some Clips” is repeatedly displayed each time you try the restoration process.
 - [1] Copy the required clips to another SxS memory card.
 - [2] Format the unusable SxS memory card on the unit.
 - [3] Copy the required clips back to the newly formatted SxS memory card.
 - [4] Update the management file as described below.

[Note]

For restoration of media recorded with this unit, be sure to use this unit.

Media recorded with a device other than this unit or with another unit of different version (even of the same model) may not be restored using this unit.

Updating the management file

If clips cannot be played back, updating the management file on the card may improve the situation.

Use TC/Media > Update Media (page 45) in the full menu to update the management file.

If you write an XAVC file that is imported by RAW Viewer V2.2 or later to the “XDROOT\Clip” directory of an SxS memory card directly, that file can become playable by executing Update Media.

Handling SD Cards for Saving Configuration Data

You can store the configuration file of the camera on an SD card (optional). The stored file can be loaded from the SD card.

Supported SD Cards

SDHC memory cards* (Speed Class: 4 to 10, non-UHS, Capacity: 2 to 32 GB)

SD memory cards* (File system: FAT 16, Capacity: up to 2 GB)

* Referred to as "SD cards" in this manual.

Inserting an SD Card

Insert an SD card into the SD card slot (page 10). The ACCESS lamp (page 8) lights in red then changes to green once the memory card is ready for use.

ACCESS lamp status

Lamp	Slot status
Lights in red	Accessing the SD card (writing/reading data)
Off	<ul style="list-style-type: none"> No SD card is loaded. The loaded card is invalid.

Removing an SD Card

Press the SD card in slightly, then remove the card.

[Notes]

- Data integrity is not guaranteed if the power is turned off or a memory card is removed while it is being accessed. Data on the card may be destroyed. Be sure that its ACCESS lamp is lit in green or off when you turn off the power or remove a memory card.
- Make sure that the card does not pop out when inserting or removing it.

Formatting (Initializing) an SD Card

SD cards must be formatted the first time they are used in the unit.

SD cards for use in the unit should be formatted using the format function of the unit. It is also necessary to format an SD memory card if a caution message is displayed when the card is loaded.

If an SD card that was formatted in an unsupported format is loaded in the unit, a file system mismatch message is displayed.

1 Select TC/Media category > Format Media > SD Card in the menu, then press the MENU dial.
A confirmation screen prompting whether to format the card appears.

2 Press and hold ITEM key 1 and ITEM key 3 for 3 seconds to execute formatting.
Formatting starts, a message is displayed during execution, and the ACCESS lamp lights in red.
When formatting ends, a completion message appears. Press the MENU dial to dismiss the message.

[Note]

All data is erased when an SD card is formatted, and the data cannot be restored.

To use media formatted with this unit in the slots of other devices

Make a backup of the media, then format it using the other device.

Using with AXS-R7

You can record video/audio in RAW or X-OCN to an AXS-R7 AXS (Access Memory Card System) Recorder (optional) by attaching the recorder to the unit.

[Note]

Update the AXS-R7 to version 1.1 before attaching it to the unit. After updating the version, remove the docking module from the AXS-R7 and attach the AXS-R7 to the unit. For details about updating the recorder, refer to the Update Guide for the AXS-R7.

Attaching the AXS-R7

[Note]

Attach/remove the AXS-R7 while the unit is turned off.

- 1 Unscrew the four hex screws (3 mm) on the rear of the unit, and remove the battery plate.

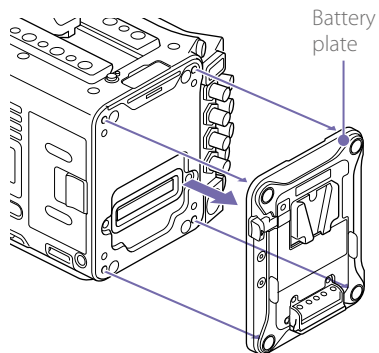

- 2 Unscrew the four hex screws on the rear of the AXS-R7, and remove the docking module from the AXS-R7.

Docking module

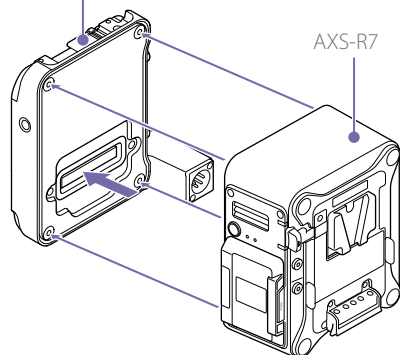

- 3 Attach the AXS-R7 to the unit, and tighten the four hex screws.

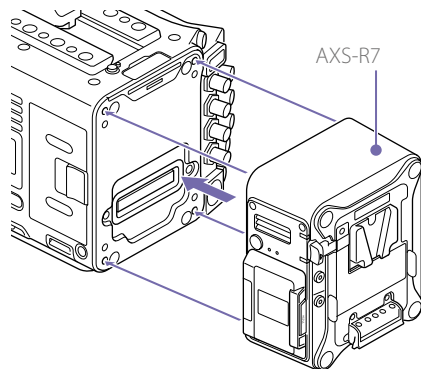

To remove the AXS-R7

Unscrew the four hex screws, and remove the AXS-R7.

Inserting an AXS Memory Card

- 1 Press the memory card slot cover open button to open the cover.

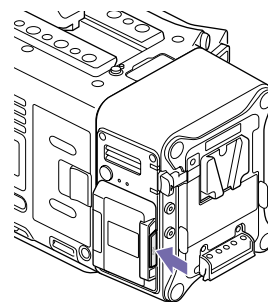

- 2 Insert the AXS memory card into the card slot with the label facing as indicated below.

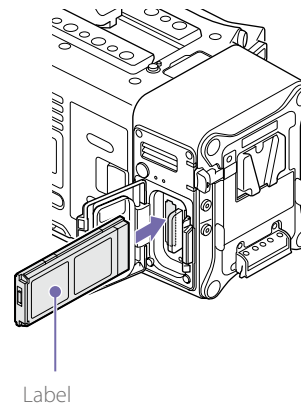

- 3 Close the cover.

Removing an AXS Memory Card

Open the memory slot cover of the AXS-R7, and pull out the AXS memory card.

[Note]

Data integrity is not guaranteed if the power is turned off or an AXS memory card is removed while it is being accessed. Data on the card may be destroyed. Be sure that its ACCESS lamp is lit in green or off when you turn off the power or remove a memory card.

Recording to an AXS Memory Card

You can select the format for recording to an AXS memory card using Project category > AXS Rec Format (page 36) in the menu.

[Note]

The AXS memory card in the AXS-R7 does not switch to the second card automatically, even if the card becomes full while recording. To switch cards, use the SLOT SELECT button on the AXS-R7 during recording standby mode.

Formatting (Initializing) an AXS Memory Card

AXS memory cards must be formatted the first time they are used in the AXS-R7 attached to the unit.

Use the format function of the unit to format AXS memory cards for use in the AXS-R7. It is also necessary to format an AXS memory card if a caution message is displayed when the unit is turned on with the AXS recorder attached.

If an AXS memory card that was formatted in a format not supported by the AXS-R7 is loaded, a file system mismatch message is displayed.

- 1 Select TC/Media category > Format Media in the menu, then press the MENU dial.
- 2 Select AXS Slot A (slot A) or AXS Slot B (slot B). A confirmation screen prompting whether to format the card appears.
- 3 Press and hold ITEM key 1 and ITEM key 3 for 3 seconds to execute formatting. Formatting starts, a message is displayed during execution, and the ACCESS lamp lights in red. When formatting ends, a completion message appears. Press the MENU dial to dismiss the message.

[Note]

All data is erased when a memory card is formatted, and the data cannot be restored.

Checking the Remaining Recording Time

While shooting (recording or standby), you can check the remaining capacity on a loaded AXS memory card using the recording media remaining capacity indicator on the Home screen of the sub display (page 27) or the viewfinder screen (page 11).

The available time for recording with the current video format (recording bit rate) is calculated according to the remaining space of each card and displayed in time units of minutes.

[Note]

A  icon appears if an AXS memory card is write-protected.

Restoring an AXS Memory Card

If for any reason an error should occur in a memory card, the card must be restored before use.

If an AXS memory card that needs to be restored is loaded, a message prompting you to execute restoration is displayed.

To start the restore process, select Execute by turning the MENU dial, then press the MENU dial.

The restoration starts.

During execution, a message is displayed and the ACCESS lamp lights in red.

When restoration ends, a completion message appears. Press the MENU dial to dismiss the message.

If restoration fails

- A write-protected AXS memory card or one on which an error occurred cannot be restored. For such a card, a warning message is displayed. Release the write protection or replace the card, according to the instructions in the message.
- An AXS memory card on which an error occurred may become usable again when reformatted.
- In some cases, some clips can be restored while others cannot. Playback of the restored clips becomes possible again.

[Note]

For restoration of media recorded with this unit, be sure to use this unit.

Media recorded with a device other than this unit or with another unit of different version (even of the same model) may not be restored using this unit.

Updating the management file

If clips cannot be played back, updating the management file on the card may improve the situation.

Use TC/Media > Update Media (page 45) in the full menu to update the management file.

Sub Display

The sub display displays the Home screen, clip list screen, playback screen, menu screen, full menu screen, and user functions screen. You can switch between the screens on the sub display using the buttons on the Assistant side of the unit.

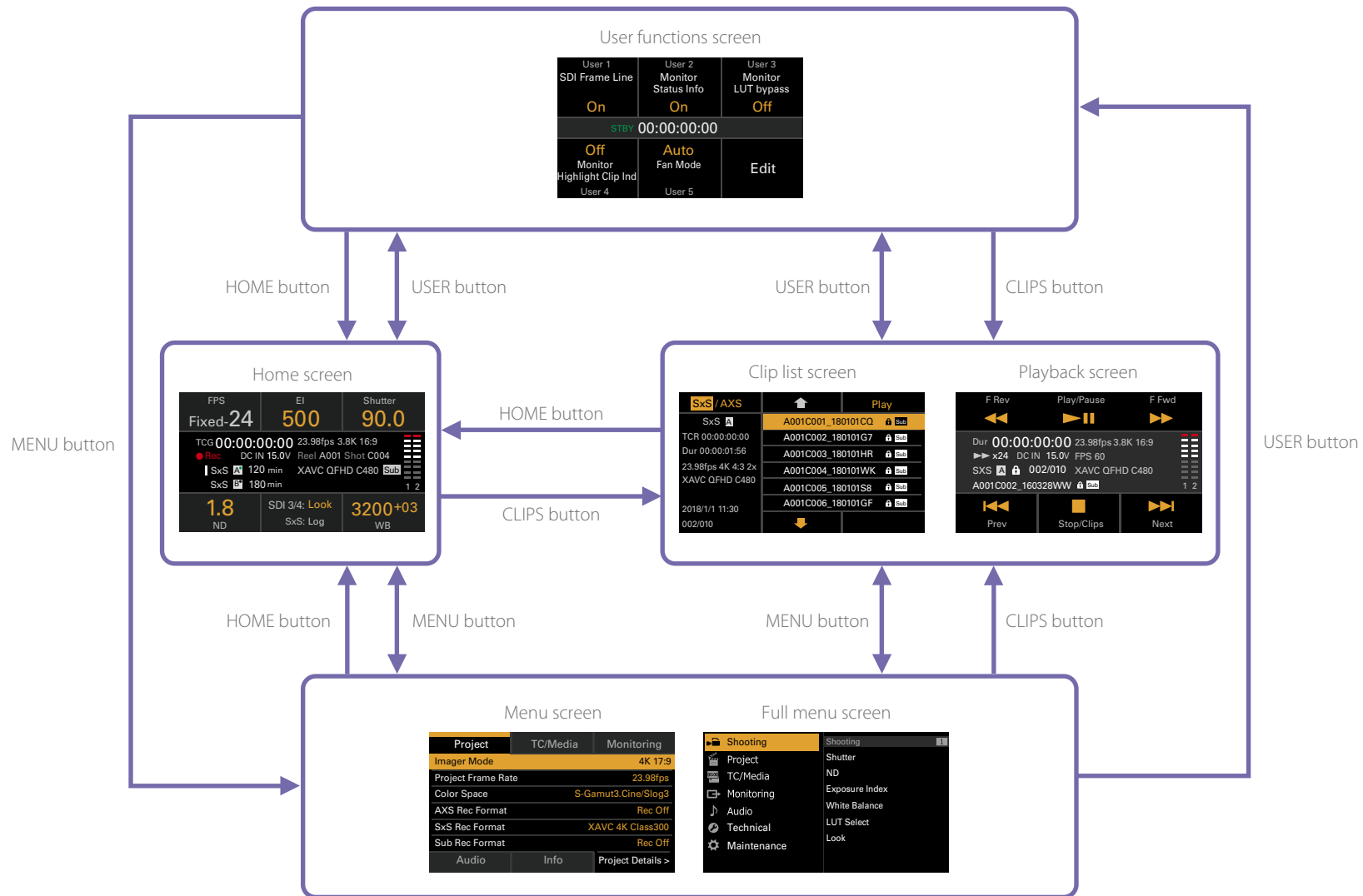

Home Screen

Press the HOME button on the Assistant side to display the Home screen. You can check the status of the unit and set basic settings for the unit on the Home screen.

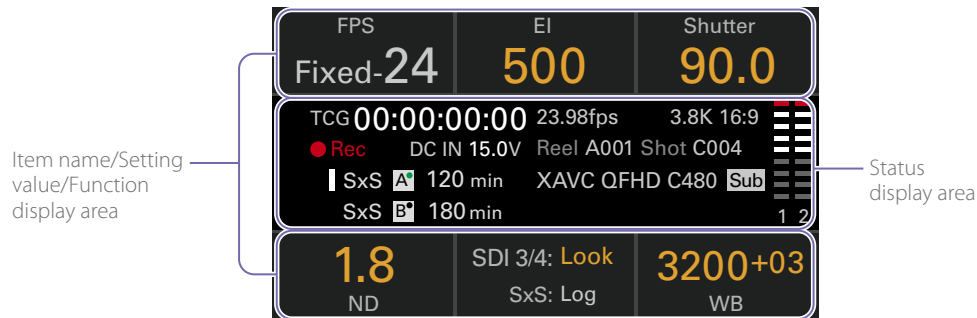

Item name/Setting value/Function display area

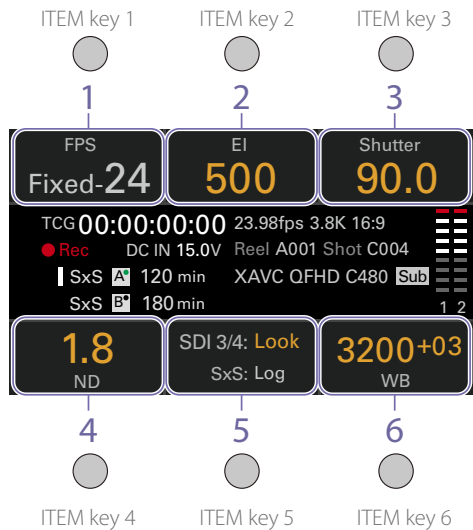

- FPS**
Displays the video frame rate.
- Exposure Index**
Displays and sets the exposure index (EI).
- Shutter**
Displays and sets the shutter speed/shutter angle of the electronic shutter.
- ND Filter**
Displays and sets the ND filter position.
- LUT**
Displays and sets the monitor LUT.
- WB (White Balance)**
Displays and sets the white balance.

[Note]

The areas labeled 1 to 6 correspond to ITEM keys 1 to 6 (page 32). Press an ITEM key to select the corresponding item. The ITEM keys for functions displayed in orange text color are enabled. FPS selection using ITEM key 1 is not supported in firmware version 1.0.

Status display area

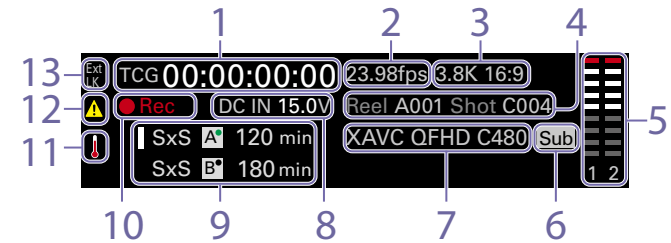

- Time data display**
Displays the duration or timecode, depending on the TC/Media category > TC Display setting in the menu (page 36).
Displays the type of data currently shown in the time data display, as follows.
TCG: Recorded timecode
TCR: Playback timecode
DUR: Duration
- Frame rate indicator**
Displays the value of the Project category > Project Frame Rate setting in the menu (page 36).
- Imager mode indicator**
Displays the Project category > Imager Mode setting in the menu, and de-squeeze information.
- Clip name display**
Displays "Reel: Camera ID + Reel Number" and "ShotNumber".
- Audio level meters**
Displays the audio recording or playback levels. The numbers 1 and 2 indicate channels 1 and 2.
- Simultaneous recording indicator**
When 1-slot simultaneous recording is configured for the displayed media, a "Sub" icon appears on the right of the displayed main recording format.
- Recording format (codec) indicator**
Displays the format of the recording on an AXS memory card or an SxS memory card (page 39).
- Power supply voltage/Remaining battery capacity indicator**
Displays the power supply voltage or remaining battery capacity.
- Remaining media capacity indicator**
Displays the active media icon, media type, slot type (A/B), and remaining recording time (when recording in the current recording format).
It also displays the clip name during playback.
- Recording status indicator**
Displays the following recording operation states of the unit.

Display	Description
Stby	Recording standby
●Rec	During recording
- Thermometer icon**
Displayed when a high temperature warning message is issued.
The description is displayed in the Info category in the menu.

12. Warning icon

Displayed when other than a high temperature warning message is issued. The description is displayed in the Info category in the menu.

13. Ext-LK icon

Displayed when the internal timecode generator is locked to an external signal input to the TC IN (timecode input) connector.

Operations on the Home Screen of the Sub Display

Basic Operation

- 1 Press the HOME button.
The Home screen appears.

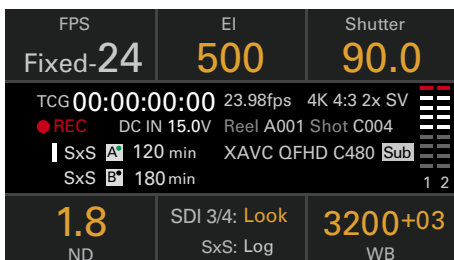

- 2 Select the item to set using the ITEM keys 1 to 6.
The setting value for items that can be changed are displayed in orange.
The following diagram shows an example when ITEM key 3 is pressed.

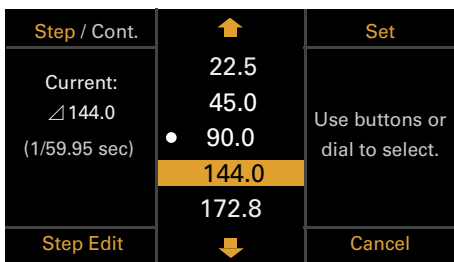

- 3 Move the cursor to the item or setting value to select using the **↑** button (ITEM key 2), **↓** button (ITEM key 5), or MENU dial.
- 4 Press the MENU dial or Set button (ITEM key 3) to apply the setting.

Changing the brightness of the sub display

You can change the brightness of the sub display using Technical > Control Display > Brightness level (page 50) in the full menu.
On the Home screen, you can also press and hold the BACK button and turn the MENU dial clockwise to change the brightness of the sub display in the sequence Minimum → Low → Mid → High with the current setting as the base point.
You can also press and hold the BACK button and turn the MENU dial counterclockwise to change the brightness of the sub display in the sequence High → Mid → Low → Minimum with the current setting as the base point.

[Note]

The display brightness setting is common to both the sub display and the mini display, and is reflected on both displays simultaneously.

Step Edit Operation

You can change the settings available for selection when "Step Edit" is displayed for ITEM key 4 in step 2 in the basic operation. You can add and delete settings on the settings edit screen.

- 1 On the settings selection screen, move the cursor to the setting you want to change or delete, and press the Step Edit button (ITEM key 4).
The settings edit screen appears.

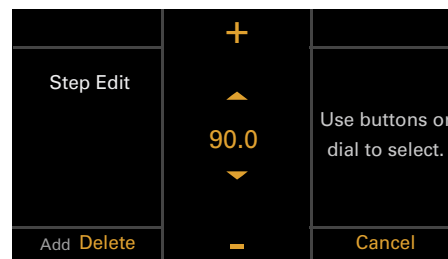

- 2 To delete a setting, press the Delete button (ITEM key 4).

[Note]

The selected setting can be deleted if the "Delete" character string is displayed in orange.

- 3 Press the **↑** button (ITEM key 2), **↓** button (ITEM key 5), or MENU dial to change a setting.

- 4 When finished, press the Add button (ITEM key 4).
The setting is added and the display returns to the setting selection screen.

[Note]

A setting can be added if the "Add" character string is displayed in orange.

When setting White Balance

On the White Balance settings edit screen, you can press the Coarse/Fine button (ITEM key 1) to change the 1-step increment variation to coarse or fine. You can also press the Temp/Tint button (ITEM key 3) to switch the value between color temperature (Temp) and color tone (Tint).

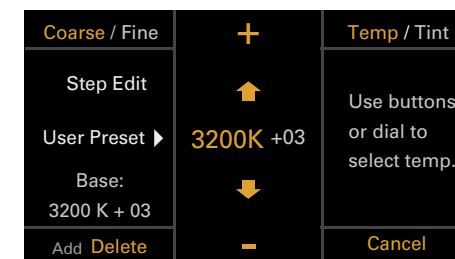

LUT Operation

Setting a LUT

You can set a LUT for each output system using ITEM key 5 on the Home screen.

- 1 Press ITEM key 5 on the Home screen.
The LUT selection screen appears.

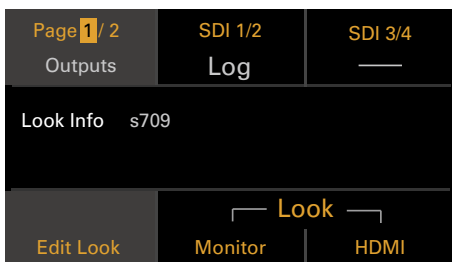

The LUT selection screen has two pages, and you can switch the page by pressing ITEM key 1. On page 1, you can set the LUT settings for SDI 1/2 (display only), SDI 3/4, Monitor, and HDMI. On page 2, you can set the LUT settings for the viewfinder, SxS Rec, and Sub Rec.

- 2 Select the output to set using ITEM keys 2, 3, 5, and 6.
The settings edit screen appears.
- 3 Press the **↑** button (ITEM key 2), **↓** button (ITEM key 5), or MENU dial to change a setting.
- 4 Press the MENU dial or Set button (ITEM key 3) to apply the setting.

Changing Preset Look

You can set a LUT when Look is selected on the LUT selection screen using the Edit Look button (ITEM key 4) on page 1 or page 2.

- 1 Press the Edit Look button (ITEM key 4) on the LUT selection screen.
The Look selection screen appears.

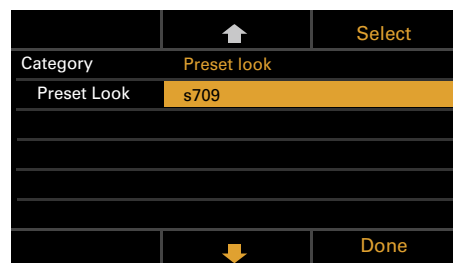

- 2 Press the Select button (ITEM key 3).
The items that can be selected are displayed.
- 3 Press the **↑** button (ITEM key 2), **↓** button (ITEM key 5), or MENU dial to change a setting.
- 4 Press the MENU dial or Set button (ITEM key 3) to apply the setting.

Home Screen Items on the Sub Display

The names of items and corresponding setting values are given below. Default values are shown underlined and in **bold** text.

Item	Description														
FPS	Displays the video frame rate. The setting is determined by the Project category > Project Frame Rate setting (page 36) in the menu.														
	<table border="1"> <thead> <tr> <th>Project Frame Rate</th> <th>Display</th> </tr> </thead> <tbody> <tr> <td>23.98</td> <td>Fixed-24</td> </tr> <tr> <td>24</td> <td>Fixed-24</td> </tr> <tr> <td>25</td> <td>Fixed-25</td> </tr> <tr> <td>29.97</td> <td>Fixed-30</td> </tr> <tr> <td>50</td> <td>Fixed-50</td> </tr> <tr> <td>59.94</td> <td>Fixed-60</td> </tr> </tbody> </table>	Project Frame Rate	Display	23.98	Fixed-24	24	Fixed-24	25	Fixed-25	29.97	Fixed-30	50	Fixed-50	59.94	Fixed-60
Project Frame Rate	Display														
23.98	Fixed-24														
24	Fixed-24														
25	Fixed-25														
29.97	Fixed-30														
50	Fixed-50														
59.94	Fixed-60														
Exposure Index	Sets the EI value. The following settings are available. 125EI/160EI/200EI/250EI/320EI/400EI/ <u>500EI</u> /640EI/800EI/1000EI/ 1250EI/1600EI/2000EI														
Shutter	Sets the electronic shutter angle/shutter speed. Press the Step/Cont. button (ITEM key 1) to switch between step and continuous selection methods. Step: Select from up to 16 preset values registered as shutter steps. You can press the Step Edit button (ITEM key 4) to change any setting from the preset value after selection. Displays the following selection options depending on the Technical > System Configuration > Shutter Mode (page 49) setting in the full menu. Angle: Shutter angle indicator Default selection options 360/180/172.8/144/90/45/22.5/11.2/5.6 Speed: Shutter speed indicator Default selection options 1/24, 1/25, 1/30, 1/50, 1/60, 1/100, 1/120, 1/250, 1/500, 1/1000, 1/2000 ¹⁾ [Note] The default speed values for different Project Frame Rate (page 36) settings are given below. 23.98/24: 1/24, 25: 1/25, 29.97: 1/30, 50: 1/50, 59.94: 1/60														

Cont.: Select an angle/speed within the supported range.

Item	Description
ND Filter	Sets the ND filter position. The following settings are available. Clear/0.3/0.6/0.9/1.2/1.5/1.8/2.1/2.4
LUT	Configures settings related to the LUT to apply to the output video. Page 1 SDI 1/2 (ITEM key 2): Log Display only, as LUT cannot be applied to the SDI 1/2 output image. SDI 3/4 (ITEM key 3): Log/Look Selects the LUT to apply to the SDI 3/4 output image. Disabled when Monitoring category > Output Format > SDI 1/2 is set to 4K/QFHD in the menu. Monitor (ITEM key 5): Log/s709/R709(800%) Selection becomes Log/Look when Monitoring category > Output Format > SDI 1/2 is set to 4K/QFHD in the menu. HDMI (ITEM key 6): Log/s709/R709(800%) Fixed to Log when Monitoring category > Output Format > SDI 1/2 is set to 4K/QFHD and HDMI is set to 4K/QFHD in the menu. In all other cases, the options are the same as for Monitor. Page 2 Viewfinder (ITEM key 2): Log/s709/R709(800%) Selects the LUT to apply to the viewfinder output image. SxS Rec (ITEM key 5): Log/Look Disabled when Project category > SxS Rec Format is set to Rec Off in the menu, or fixed to Log when set to XAVC. Sub Rec (ITEM key 6): Log/Look Disabled when Project category > SxS Rec Format is set to Rec Off in the menu. Page 1/2 common items Edit Look: Sets a LUT to apply as a Look. s709/R709(800%)
WB (White Balance)	Sets the color temperature/color tone of the white balance. Default selection options 3200K+00/4300K+00/5500K+00 You can press the Step Edit button (ITEM key 4) to change the white balance preset value and Tint value.

¹⁾ The options are 1/60 and subsequent values when the project frame rate is 59.94, 1/50 and subsequent values when 50.0, 1/30 and subsequent values when 29.97, and 1/25 and subsequent values when 25.0.

User Functions Screen

You can press the USER button (page 8) to display the user functions screen on the sub display and use the ITEM keys 1 to 5 as assignable buttons (User 1 to 5).

There are also four assignable buttons (pages 6, 7, 8) to which you can assign various functions.

Functions can be assigned to these buttons using the user functions screen, in addition to using Project > Assignable Button in the full menu.

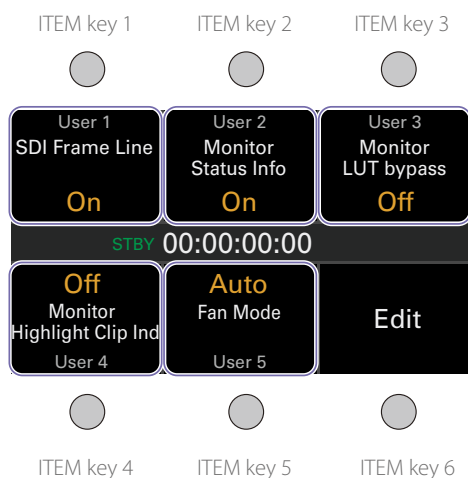

Changing Button Functions

The user functions selection screen is displayed by pressing the Edit button (ITEM key 6) on the user functions screen. You can set the functions for the User 1 to 5 buttons and assignable buttons 1 to 4 on the user functions selection screen.

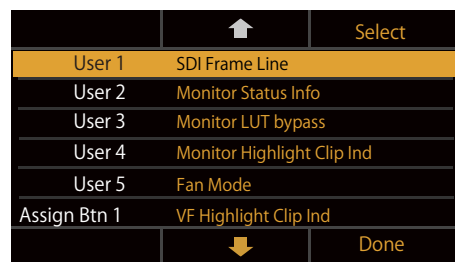

- 1 On the user functions selection screen, move the cursor to the button you want to change, and press the Select button (ITEM key 3). The functions that can be selected are displayed.

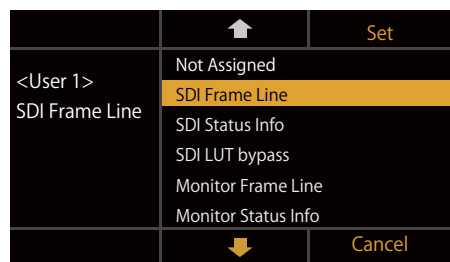

- 2 Press the **↑** button (ITEM key 2), **↓** button (ITEM key 5), or MENU dial to change a setting.
- 3 When finished, press the Set button (ITEM key 3). The display returns to the user functions screen, and displays the changed function.

The following tables lists the functions that are assigned when the unit is shipped from the factory.

Button	Function	Assignable Button setting
Assignable 1	Displays clipped highlight areas in red in the viewfinder.	VF Highlight Clip Ind
Assignable 2	No assignment	Not Assigned
Assignable 3	No assignment	Not Assigned
Assignable 4	No assignment	Not Assigned
ITEM key 1	No assignment	Not Assigned
ITEM key 2	No assignment	Not Assigned
ITEM key 3	No assignment	Not Assigned
ITEM key 4	Displays clipped highlight areas in red on the Monitor output.	Monitor Highlight Clip Ind
ITEM key 5	Sets the fan control mode.	Fan Mode

Functions that can be Assigned to ITEM Keys 1 to 5

Assignable Button setting	Function	State when unit is powered on
Not Assigned	No assignment	–
SDI Frame Line	Turns superimposition of frame lines on the SDI 3/4 output image on/off.	Setting retained
SDI Status Info	Turns display of information on the SDI 3/4 output image on/off.	Setting retained
SDI LUT bypass	Disables the LUT applied to the SDI 3/4 output image while the key is pressed, and sets Log image quality without applying a LUT.	Setting not retained
Monitor Highlight Clip Ind	Turns the function that displays clipped highlight areas in red on the Monitor output image on/off.	Setting retained
Monitor Frame Line	Turns superimposition of frame lines on the Monitor output image on/off.	Setting retained
Monitor Status Info	Turns display of information on the Monitor output image on/off.	Setting retained
Monitor LUT bypass	Disables the LUT applied to the Monitor output image while the button is pressed, and sets Log image quality without applying a LUT.	Setting not retained
Color Bars	Turns color bars on/off.	Setting retained
AXS Slot Change	Switches the active slot when two AXS memory cards are inserted. Switches between A and B each time the key is pressed.	Setting retained

Assignable Button setting	Function	State when unit is powered on
SxS Slot Change	Switches the active slot when two SxS memory cards are inserted. Switches between A and B each time the key is pressed.	Setting retained
Fan Mode	Sets the fan control mode. Switches between Auto → Max → Off in Rec/ Auto → Off in Rec/Max each time the key is pressed.	Setting retained
Format Media AXS Slot A	Formats media in AXS slot A.	–
Format Media AXS Slot B	Formats media in AXS slot B.	–
Format Media SxS Slot A	Formats media in SxS slot A.	–
Format Media SxS Slot B	Formats media in SxS slot B.	–
APR	Executes APR.	–
Lens Interface	Selects the lens interface. Switches between Off → Type C each time the key is pressed.	Setting retained
VF Highlight Clip Ind	Turns the function to display clipped highlight areas in red in the viewfinder on/off.	Setting retained

Functions that can be Assigned to Assignable Buttons 1 to 4

Assignable Button setting	Function	State when unit is powered on
Not Assigned	No assignment	–
SDI Frame Line	Turns superimposition of frame lines on the SDI 3/4 output image on/off.	Setting retained
SDI Status Info	Turns display of information on the SDI 3/4 output image on/off.	Setting retained
SDI LUT bypass	Disables the LUT applied to the SDI 3/4 output image while the button is pressed, and sets Log image quality without applying a LUT.	Setting not retained
Monitor Frame Line	Turns superimposition of frame lines on the Monitor output image on/off.	Setting retained
Monitor Status Info	Turns display of information on the Monitor output image on/off.	Setting retained
Monitor LUT bypass	Disables the LUT applied to the Monitor output image while the button is pressed, and sets Log image quality without applying a LUT.	Setting not retained
Monitor Highlight Clip Ind	Turns the function that displays clipped highlight areas in red on the Monitor output image on/off.	Setting retained
Color Bars	Turns color bars on/off.	Setting retained
AXS Slot Change	Switches the active slot when two AXS memory cards are inserted. Switches between A and B each time the button is pressed.	–
SxS Slot Change	Switches the active slot when two SxS memory cards are inserted. Switches between A and B each time the button is pressed.	–
Rec Review	Executes the Rec Review function.	Setting not retained
VF Frame Line	Turns superimposition of frame lines on the viewfinder output image on/off.	Setting retained
VF Zebra	Turns the zebra function of the viewfinder output image on/off.	Setting retained
VF Status Info	Turns the information display on the viewfinder output image on/off.	Setting retained

Assignable Button setting	Function	State when unit is powered on
VF Focus Magnifier	Turns the focus magnifier function of the viewfinder on/off.	Setting not retained
VF LUT bypass	Disables the LUT applied to the viewfinder output image while the button is pressed, and sets Log image quality without applying a LUT.	Setting not retained
VF Highlight Clip Ind	Turns the function to display clipped highlight areas in red in the viewfinder on/off.	Setting retained

Menu Operations

By pressing the MENU button while shooting (during recording or recording standby) or during playback, you can display and operate the menu screen on the sub display.

- Project category: Basic settings and recording format settings
- TC/Media category: Timecode value and TC format settings
- Monitoring category: SDI/HDMI/Monitor external signal output format, OSD, and marker overlay status settings
- Audio category: Audio source and audio level settings
- Info category: Camera, media, and battery status information

Controls

MENU button (page 7)

Press to display the menu on the sub display.

ITEM keys 1 to 6 (page 7)

Selects the category of the menu.

SEL/SET dial (MENU dial) (page 7)

Turn to move the cursor in the corresponding direction to select setting items or setting values. Press the MENU dial to apply the selected item.

BACK button (page 8)

Press to return to the previous menu. Unconfirmed changes are canceled.

Basic Operation

- 1 Press the MENU button.
The menu screen appears.
- 2 Select the category to set using ITEM keys 1 to 6.
- 3 Turn the MENU dial to move the cursor to the setting item to select.
For each setting item, the setting value is displayed.

"Menu Item List" (page 36)

Project	TC/Media	Monitoring
Imager Mode		4K 17:9
Project Frame Rate		23.98
Input Color Space		S-Gamut3.Cine/Slog3
AXS Rec Format		Rec Off
SxS Rec Format		XAVC 4K Class300
Sub Rec Format		Rec Off
Audio	Info	Project Details >

- 4 Press the MENU dial.
The setting value selection screen appears next to the selected item.

Project	TC/Media	Monitoring
Imager Mode		4K 4:3
Project Frame Rate		4K 17:9
Input Color Space		3.8K 16:9
AXS Rec Format		Rec Off
SxS Rec Format		XAVC 4K Class300
Sub Rec Format		Rec Off
Audio	Info	Project Details >

- 5 Turn the MENU dial to move the cursor to the setting value.
- 6 Press the MENU dial to apply the setting.

Menu Item List

The items available in each category are given below.

Project category

Default values are shown underlined and in **bold** text.

Item	Settings	Description
Imager Mode	6K 3:2/4K 4:3/ 4K 17:9 /3.8K 16:9	Sets the effective picture size. [Notes] <ul style="list-style-type: none"> • “6K 3:2” and “4K 4:3” are displayed only when a license is installed. • Clips recorded in 6K 3:2 cannot be played back on the unit.
Project Frame Rate	23.98 /24/25/29.97/50/59.94	Sets the project frame rate.
Input Color Space	S-Gamut3.Cine/Slog3	Sets the color space. Fixed to S-Gamut3.Cine/Slog3 in firmware version 1.0.
AXS Rec Format ¹⁾ (Only when an AXS-R7 is attached)	Rec Off /RAW SQ/X-OCN ST/X-OCN LT	Sets the recording format for AXS memory cards when an AXS-R7 is connected.
SxS Rec Format ¹⁾	Rec Off/XAVC 4K Class480/ XAVC 4K Class300 /XAVC QFHD Class480/XAVC QFHD Class300/MPEG HD P/MPEG HD i	Sets the main recording format for SxS memory cards.
Sub Rec Format ¹⁾	Rec Off /MPEG HD P/MPEG HD i	Sets the sub recording format for SxS memory cards.
Project Details (ITEM key 6)		Displays the contents of the Project menu (page 43) in the full menu.

¹⁾ The recording formats available vary depending on the combination of the effective picture size and project frame rate settings. For details about settings, see “Recording Format Settings” (page 39).

TC/Media category

Default values are shown underlined and in **bold** text.

Item	Settings	Description
TC Mode	Preset F-Run (Ext-Lk)/ Preset R-Run /Int Regen	Sets the timecode mode. Preset F-Run (Ext-Lk): Timecode advances continuously from specified value, regardless of whether recording or not. Preset R-Run: Timecode advances from specified value only when recording. Int Regen: Timecode continues from that of the previous clip.
TC Display	Timecode /Duration	Switches the time data indication.
TC Setting (set when switching to another screen)	Setting (H, M, S, F)	Sets the timecode to a desired value.
	Reset	Resets the timecode to 00:00:00:00.
	TC Format	DF /NDF DF: Drop frame NDF: Non drop frame
	TC Source	Internal/External Display only.
Cam ID	A to Z	Sets the camera ID used when generating clip names. Clip name: Camera ID + Reel Number + Shot Number + date + random string
Reel#	001 to 999	Sets the numeric portion of the Reel Number used when generating clip names. Clip name: Camera ID + Reel Number + Shot Number + date + random string
Camera Position	C /L/R	Sets the first character portion of the Shot Number used when generating clip names. Clip name: Camera ID + Reel Number + Shot Number + date + random string

Item	Settings	Description
Format Media (executed when switching to another screen)	AXS Slot A	Formats the AXS memory card in slot A.
	AXS Slot B	Formats the AXS memory card in slot B.
	SxS Slot A	Formats the SxS memory card in slot A.
	SxS Slot B	Formats the SxS memory card in slot B.
	SD Card	Formats the SD card.
Media Details (ITEM key 6)		Displays the contents of the TC/Media menu (page 44) in the full menu.

Monitoring category

Default values are shown underlined and in **bold** text.

[Notes]

- The unit supports independent configuration of Info and Frame Line for each system. The display information for the A and B output images is configured using the Monitoring menu (page 45).
- Info and Frame Line may not be displayed depending on the Output Format setting. In this case, “–” is displayed and the setting cannot be changed.

Item	Settings	Description	
VF	Info	<u>A/B/Off</u>	Selects the information to display superimposed on the viewfinder image.
	Frame Line	<u>A/B/Off</u>	Selects the frame lines to display superimposed on the viewfinder image.
SDI 1/2	Output Format	The available settings vary according to the imager mode, project frame rate, and SxS recording format settings.	Selects the SDI 1/2 output format. ¹⁾
	Info	–	Information display is not superimposed on the SDI 1/2 output.
	Frame Line	<u>A/B/Off</u>	Selects the frame lines to display superimposed on the SDI 1/2 output.

[Note]
Frame lines are only superimposed if the output format is 4K/QFHD.

Item	Settings	Description	
SDI 3/4 [Note] Depending on the Output Format setting of SDI 1/2, the Output Format, Info, Frame Line settings of SDI 3/4 may be blank and cannot be changed.	Output Format	The available settings vary depending on the SDI 1/2 setting.	Selects the SDI 3/4 output format. ¹⁾
	Info	<u>A/B/Off</u>	Selects the information to display superimposed on the SDI 3/4 output.
	Frame Line	<u>A/B/Off</u>	Selects the frame lines to display superimposed on the SDI 3/4 output.
Monitor	Output Format	The available settings vary depending on the SDI 1/2 setting.	Selects the Monitor output format. ²⁾
	Info	<u>A/B/Off</u>	Selects the information to display superimposed on the Monitor output.
	Frame Line	<u>A/B/Off</u>	Selects the frame lines to display superimposed on the Monitor output.
HDMI	Output Format	The available settings vary depending on the SDI 1/2 setting.	Selects the HDMI output format. ²⁾
Moni. Details (ITEM key 6)		Displays the contents of the Monitoring menu (page 45) in the full menu.	

¹⁾ For details about formats available for selection, see “SDI OUT Connector Output Formats” (page 64).

²⁾ For details about formats available for selection, see “MONITOR OUT Connector/HDMI OUT Connector Output Formats” (page 66).

Audio category

Default values are shown underlined and in **bold** text.

Item	Settings	Description
Source Switch	LINE / AES/EBU / MIC	Displays the position of the AUDIO IN switch (page 7) that sets the CH1 and CH2 input source.
CH-1 Audio Level	Auto/Manual –99 to <u>±0</u> to +99	The audio recording level is adjusted automatically when set to Auto. The audio recording level is adjusted manually when set to Manual.
CH-2 Audio Level	Auto/Manual –99 to <u>±0</u> to +99	The audio recording level is adjusted automatically when set to Auto. The audio recording level is adjusted manually when set to Manual.
MIC Reference	–60dB/ <u>–50dB</u> –40dB	Selects the reference input level of the microphone.
Monitor CH	When Monitor Output CH Pair is set to CH-1/CH-2 <u>CH-1/CH-2</u> , CH-1, CH-2 When Monitor Output CH Pair is set to CH-3/CH-4 <u>CH-3/CH-4</u> , CH-3, CH-4	Selects the audio channel that is output to the headphones and speaker.
Monitor Level	<u>0</u> to 99	Adjusts the monitor audio level.
CH1 Level Meter	–	Displays the CH1 level meter.
CH2 Level Meter	–	Displays the CH2 level meter.
CH3 Level Meter	–	Displays the CH3 level meter.
CH4 Level Meter	–	Displays the CH4 level meter.
Audio Details (ITEM key 6)		Displays the contents of the Audio menu (page 48) in the full menu.

Checking the Status using the Info Category

You can check the status of media and the battery, and check the contents of warnings and errors that are issued using the Info category. The contents of the display update in realtime as the status of the unit changes.

The Info category consists of the following six information pages. Turn the MENU dial to switch the page.

No.	Page	Description
1	Camera Condition	Displays warning messages and error messages. When there are no messages, "All Systems are OK" is displayed at the top of the display area.
2	Firmware	Displays the firmware version of the unit, the serial number and firmware version of the AXS-R7 attached to the unit, and the name and validity of option software licenses on the unit. If an option is not added or currently valid, "Not Installed" or "Expired" is displayed.
3	System	Displays the following system information. <ul style="list-style-type: none"> • Date and time • Fan rotation speed • Sensor detection temperature • Hours meter • IP Address
4	Battery	Displays the following battery information. <ul style="list-style-type: none"> • Detected battery name or type • Remaining capacity (%) • Estimated remaining time • Remaining capacity (Ah) • Voltage (V) • Number of times that the battery has been charged • Power source • Supplied power source voltage
5	Media	Displays the remaining capacity, remaining recording time, and lifespan data of SxS memory cards, AXS memory cards (when AXS-R7 is attached), and SD cards.
6	Lens	Displays the following information for the lens attached to the unit. <ul style="list-style-type: none"> • Lens model name • T value of iris • Focal length • Focus distance • Depth of field • Serial number

Recording Format Settings

The following recording formats can be selected for different combinations of effective picture size and project frame rate settings.

If a value shown underlined and in **bold** text is selected, a LUT setting can be applied to the recorded video signal.

Project Frame Rate	Effective picture size (Imager Mode)	Main recording format		SxS sub recording format (Sub Rec Format)
		AXS Rec Format	SxS Rec Format	
23.98	4K 17:9 (4096×2160)	Off	Off	–
			4K XAVC-I Class480	Off
			4K XAVC-I Class300	Off
		RAW/X-OCN ST/X-OCN LT	Off	–
		MPEG HD422¹⁾	–	
		MPEG HD422¹⁾	–	
	3.8K 16:9 (3840×2160)	Off	Off	Off
			QFHD XAVC-I Class480	Off
			QFHD XAVC-I Class300	Off
		RAW/X-OCN ST/X-OCN LT	Off	–
		MPEG HD422	–	
		MPEG HD422	–	
4K 4:3 Anamorphic (4096×3024)	Off	Off	Off	
	X-OCN ST/X-OCN LT	Off	–	
	MPEG HD422¹⁾	–		
6K 3:2 (6048×4032)	Off	Off	Off	
	X-OCN ST/X-OCN LT	Off	Off	

Project Frame Rate	Effective picture size (Imager Mode)	Main recording format		SxS sub recording format (Sub Rec Format)	
		AXS Rec Format	SxS Rec Format		
24	4K 17:9 (4096×2160)	Off	Off	–	
			4K XAVC-I Class480	Off	
			4K XAVC-I Class300	Off	
	RAW/X-OCN ST/X-OCN LT	Off	–		
	3.8K 16:9 (3840×2160)	Off	Off	Off	
			RAW/X-OCN ST/X-OCN LT	Off	
RAW/X-OCN ST/X-OCN LT			Off		
4K 4:3 Anamorphic (4096×3024)	Off	Off	Off		
		X-OCN ST/X-OCN LT	Off		
		X-OCN ST/X-OCN LT	Off		
6K 3:2 (6048×4032)	Off	Off	Off		
		X-OCN ST/X-OCN LT	Off		
25/29.97	4K 17:9 (4096×2160)	Off	Off	–	
			4K XAVC-I Class480	Off	
			4K XAVC-I Class300	Off	
			RAW/X-OCN ST/X-OCN LT	Off	–
			MPEG HD422¹⁾	–	
			MPEG HD422¹⁾	–	
	3.8K 16:9 (3840×2160)	Off	Off	Off	
			QFHD XAVC-I Class480	Off	
			QFHD XAVC-I Class300	Off	
		RAW/X-OCN ST/X-OCN LT	Off	–	
		MPEG HD422¹⁾	–		
		MPEG HD422	–		
4K 4:3 Anamorphic (4096×3024)	Off	Off	Off		
		X-OCN ST/X-OCN LT	Off		
		MPEG HD422	–		
6K 3:2 (6048×4032)	Off	Off	Off		
		X-OCN ST/X-OCN LT	Off		

Project Frame Rate	Effective picture size (Imager Mode)	Main recording format		SxS sub recording format (Sub Rec Format)
		AXS Rec Format	SxS Rec Format	
50/59.94	4K 17:9 (4096×2160)	Off	Off	–
			4K XAVC-I Class300	Off MPEG HD422 ¹⁾
			RAW/X-OCN ST/X-OCN LT	Off MPEG HD422 ¹⁾
	3.8K 16:9 (3840×2160)	Off	Off	Off
			QFHD XAVC-I Class300	Off MPEG HD422
			MPEG HD422	–
	RAW/X-OCN ST/X-OCN LT	Off MPEG HD422	– –	

¹⁾ Horizontal frame with black bars across top and bottom (letterboxing).

Full Menu Operations

The full menu for configuring the required settings for shooting and playback is displayed on the sub display by pressing and holding the MENU button for 2 seconds or longer.

Menu Structure

Shooting menu

Menu used to make settings related to shooting.

Project menu

Menu used to make basic settings for a project.

TC/Media menu

Menu used to make settings related to timecode and recording media.

Monitoring menu

Menu used to make settings related to video output and viewfinder output.

Audio menu

Menu used to make settings related to audio.

Technical menu

Menu used to make settings related to technical matters.

Maintenance menu

Menu used to make unit settings, such as the clock and language settings.

Controls

MENU button (page 7)

Press and hold for 2 seconds or longer to display the full menu on the sub display.

SEL/SET dial (MENU dial) (page 7)

Turn to move the cursor in the corresponding direction to select setting items or setting values. Press the MENU dial to apply the selected item.

BACK button (page 8)

Press to return to the previous menu. Unconfirmed changes are canceled.

Setting Menu Items

Turn the MENU dial to move the cursor to the menu item you want to set, then press the MENU dial to select that item.

- The menu item selection area can show a maximum of nine lines. When all the selectable items cannot be displayed at one time, you can scroll the display up or down by moving the cursor.
- For items having a wide range of available values (example: -99 to +99), the selection area is not displayed. The current setting is highlighted to indicate that the value can be changed.
- If you select Execute for an executable item, the corresponding function is executed.
- When you select an item that you must confirm before execution, a confirmation message appears. Follow the instructions in the message to execute or cancel the operation.

Full Menu List

The functions and available settings of each menu item are given below.

Shooting Menu

Default values are shown underlined and in **bold** text.

Shooting > Shutter		
Makes settings related to the electronic shutter.		
Menu item	Settings	Description
Shutter Select	When Shutter Mode (page 49) is set to Speed Default selection options 1/24, 1/25, 1/30, 1/50, 1/60, 1/100, 1/120, 1/250, 1/500, 1/1000, 1/2000 ¹⁾ When Shutter Mode (page 49) is set to Angle Default selection options 360.0/ 180.0 /172.8/144.0/ 90.0/45.0/22.5/11.2/5.6 When Step/Cont. Select is set to Continuous, the selection range is 360.0 to 4.2 (Angle) or 1/24 ¹⁾ to 1/8000 ²⁾ (Speed).	Selects shutter angle or speed of the electronic shutter. The default speed values for different Project Frame Rate (page 43) settings are given below. 23.98/24: 1/24 25: 1/25 29.97: 1/30 50: 1/50 59.94: 1/60
Step/Cont. Select	Step /Continuous	Selects whether the electronic shutter values are step values or continuous.
Add/Change Step		Adds or edits a selection option available in Shutter Select in Step mode. Up to 16 selection options can be added.
Delete Step		Deletes a selection option available in Shutter Select in Step mode.
Shooting > ND		
Sets the ND filter position.		
Menu item	Settings	Description
ND Position	Clear /0.3/0.6/0.9/1.2/1.5/1.8/ 2.1/2.4	Selects the density of the ND filter.
Shooting > Exposure Index		
Sets the EI value.		
Menu item	Settings	Description
EI Select	125EI/160EI/200EI/250EI/320EI/ 400EI/ 500EI /640EI/800EI/1000EI/ 1250EI/1600EI/2000E	Selects the EI value.

Shooting > White Balance		
Makes settings related to white balance.		
Menu item	Settings	Description
Color Temp. Select	3200K+00 /4300K+00/ 5500K+00 + other added options (up to 16)	Displays and selects the color temperature/color tone of the white balance.
Add/Change Step		Adds or edits a selection option by changing the color temperature and tint value of white balance.
Delete Step		Deletes an added selection option.
Shooting > LUT Select		
Makes settings related to the LUT to apply to the output image.		
Menu item	Settings	Description
SDI 1/2	Log	Display only, as LUT cannot be applied to the SDI 1/2 output image.
SDI 3/4	Log/ Look /---	Selects the LUT to apply to the SDI 3/4 output image.
Monitor	Log/s709/R709(800%)/ Look /--- The default values are given below. When Output Format > SDI 1/2 is 2K/HD: s709 When Output Format > SDI 1/2 is 4K/QFHD: Look	Selects the LUT to apply to the Monitor output image.
HDMI	Log/s709/R709(800%)/ Look The default values are given below. When Output Format > SDI 1/2 is 2K/HD: s709 When Output Format > SDI 1/2 is 4K/QFHD and HDMI is not 4K/QFHD: Look When Output Format > HDMI is 4K/QFHD: Log	Displays the LUT to apply to HDMI output image.
VF LUT	Log/ s709 /R709(800%)	Selects the LUT to apply to the viewfinder output image.
SxS Rec	Log /Look/---	Selects the LUT to apply to SDI Main clip recorded video.
Sub Rec	Log/ Look /---	Selects the LUT to apply to SDI Sub clip recorded video.

Shooting > Look

Makes settings related to Preset Look.

Menu item	Settings	Description
Category	Preset Look	Displays the LUT category.
Preset Look Select	<u>s709</u> /R709(800%)	Selects the Preset Look. Outputs images that are suitable as the starting point for color grading or images that are close to print film quality. s709: Cinema color R709(800%): Faithful color

¹⁾ The options are 1/60 and subsequent values when the project frame rate is 59.94, 1/50 and subsequent values when 50.0, 1/30 and subsequent values when 29.97, and 1/25 and subsequent values when 25.0.

²⁾ The options are 1/7000 and preceding values when the project frame rate is 50.0 or 25.0, and 1/6000 and preceding values when 24.0 or 23.98.

Project Menu

Default values are shown underlined and in **bold** text.

Project > Basic Setting

Makes settings related to picture size and project frame rate.

Menu item	Settings	Description
Imager Mode	6K 3:2/4K 4:3/ <u>4K 17:9</u> /3.8K 16:9	Selects the effective picture size. [Notes] <ul style="list-style-type: none"> • "6K 3:2" and "4K 4:3" are displayed only when a license is installed. • Clips recorded in 6K 3:2 cannot be played back on the unit.
Project Frame Rate	<u>23.98</u> /24/25/29.97/50/59.94	Selects the project frame rate.
AXS Rec Format (Only when an AXS-R7 is attached)	<u>Rec Off</u> /RAW SQ/X-OCN ST/X-OCN LT	Selects the video format for recording onto an AXS memory card inserted into an AXS-R7.
SxS Rec Format	Rec Off/XAVC 4K Class480/ <u>XAVC 4K Class300</u> /XAVC QFHD Class480/XAVC QFHD Class300/MPEG HD P/MPEG HD i	Selects the video format to be recorded on an SxS memory card.
Sub Rec Format	<u>Rec Off</u> /MPEG HD P/MPEG HD i	Selects the sub recording format for SxS memory cards.
SxS/Output De-Squeeze	×2.0	Displays the de-squeeze process status for SxS recording signals and video output signals. Displayed only when Imager Mode is set to 4K 4:3.

Project > Assignable Button

Assigns functions to assignable buttons.

For details about assigning functions, see "User Functions Screen" (page 32).

Menu item	Settings	Description
<1>	page 32	Assigns a function to assignable button 1.
<2>	page 32	Assigns a function to assignable button 2.
<3>	page 32	Assigns a function to assignable button 3.
<4>	page 32	Assigns a function to assignable button 4.
<User 1>	page 32	Assigns a function to ITEM key 1.
<User 2>	page 32	Assigns a function to ITEM key 2.
<User 3>	page 32	Assigns a function to ITEM key 3.
<User 4>	page 32	Assigns a function to ITEM key 4.
<User 5>	page 32	Assigns a function to ITEM key 5.

Project > All File		
Makes settings related to All-settings files.		
Menu item	Settings	Description
Load SD Card		Load an All-settings file from an SD card.
Save SD Card		Save an All-settings file on an SD card.
File ID		Displays the file ID of the All-settings file for editing.
Format SD Card		Formats an SD card.

TC/Media Menu

Default values are shown underlined and in **bold** text.

TC/Media > Timecode		
Makes settings related to timecode.		
Menu item	Settings	Description
Mode	Preset F-Run (Ext-Lk)/ <u>Preset R-Run</u> /Int Regen	Selects the timecode mode. Preset F-Run (Ext-Lk): Timecode advances continuously from specified value, in sync with external input timecode. Preset R-Run: Timecode advances from specified value only when recording. Int Regen: Timecode continues from that of the previous clip.
Manual Setting	<u>00:00:00:00</u> to 23:59:59:29	Sets an arbitrary timecode value.
Reset	Execute/Cancel	Resets the timecode to 00:00:00:00 (execute by selecting Execute).
TC Format	<u>DF</u> /NDF	Selects the timecode format. DF: Drop frame NDF: Non drop frame
TC Source	Internal/External	Displays the TCG sync source.
Time Data Display	<u>Timecode</u> /Duration	Selects the time data to display.
TC/Media > Clip Name Format		
Sets clip names. (Clip name: Camera ID + Reel Number + Shot Number + date + random string)		
Menu item	Settings	Description
Camera ID	<u>A</u> to Z	Sets the camera ID used when generating clip names.
Reel Number	<u>001</u> to 999	Sets the numeric portion of the Reel Number used when generating clip names.
Camera Position	<u>C</u> /L/R	Sets the first character portion of the Shot Number used when generating clip names.
TC/Media > Format Media		
Formats media.		
Menu item	Settings	Description
AXS Slot A (Only when an AXS-R7 is attached)	Execute/Cancel	Initializes the AXS memory card in slot A (execute by selecting Execute).
AXS Slot B (Only when an AXS-R7 is attached)	Execute/Cancel	Initializes the AXS memory card in slot B (execute by selecting Execute).

TC/Media > Format Media		
Formats media.		
Menu item	Settings	Description
SxS Slot A	Execute/Cancel	Initializes the SxS memory card in slot A (execute by selecting Execute).
SxS Slot B	Execute/Cancel	Initializes the SxS memory card in slot B (execute by selecting Execute).
SD Card	Execute/Cancel	Formats the SD card (execute by selecting Execute).

TC/Media > Update Media		
Updates the media's management file.		
Menu item	Settings	Description
AXS Slot A (Only when an AXS-R7 is attached)	Execute/Cancel	Updates the management file on the AXS memory card in slot A of the AXS recorder (execute by selecting Execute).
AXS Slot B (Only when an AXS-R7 is attached)	Execute/Cancel	Updates the management file on the AXS memory card in slot B of the AXS recorder (execute by selecting Execute).
SxS Slot A	Execute/Cancel	Updates the management file on the SxS memory card in slot A (execute by selecting Execute).
SxS Slot B	Execute/Cancel	Updates the management file on the SxS memory card in slot B (execute by selecting Execute).

Monitoring Menu

Default values are shown underlined and in **bold** text.

Monitoring > Output Format		
Makes settings related to output format.		
Menu item	Settings	Description
SDI 1/2	The available settings vary according to the imager mode, project frame rate, and SxS recording format settings.	Selects the SDI 1/2 output format. Settings vary according to the recording format (page 64).
SDI 3/4	The available settings vary depending on the SDI 1/2 setting.	Selects the SDI 3/4 output format. Settings vary according to the recording format (page 64).
Monitor	The available settings vary depending on the SDI 1/2 setting.	Selects the Monitor output format. Settings vary according to the recording format (page 66).
HDMI	The available settings vary depending on the SDI 1/2 setting.	Selects the HDMI output format. Settings vary according to the recording format (page 66).

Monitoring > VF OSD		
Makes settings related to information and frame lines superimposed on the viewfinder output signal.		
Menu item	Settings	Description
Status Info	<u>On</u> /Off	Turns the function to superimpose information on the viewfinder output signal on/off.
Status Info Select	<u>Info. A</u> /Info. B	Selects the information to display superimposed on the viewfinder output signal.
Frame Line	On/ <u>Off</u>	Turns the function to superimpose frame lines on the viewfinder output signal on/off.
Frame Line Select	<u>Frame Line A</u> /Frame Line B	Selects the frame lines to display superimposed on the viewfinder output signal.

Monitoring > SDI OSD		
Makes settings related to information and frame lines superimposed on the SDI output signal.		
Menu item	Settings	Description
Status Info	<u>On</u> /Off	Turns the function to superimpose information on the SDI 3/4 output signal on/off.
Status Info Select	Info. A/ <u>Info. B</u>	Selects the information to display superimposed on the SDI 3/4 output signal.
Frame Line	On/ <u>Off</u>	Turns the function to superimpose frame lines on the SDI 3/4 output signal on/off.

Monitoring > SDI OSD

Makes settings related to information and frame lines superimposed on the SDI output signal.

Menu item	Settings	Description
Frame Line Select	Frame Line A/ Frame Line B	Selects the frame lines to display superimposed on the SDI 3/4 output signal.

Monitoring > Monitor OSD

Makes settings related to information and frame lines superimposed on the Monitor/HDMI output signal.

Menu item	Settings	Description
Status Info	On/Off	Turns the function to superimpose information on the Monitor/HDMI output signal on/off.
Status Info Select	Info. A/ Info. B	Selects the information to display superimposed on the Monitor/HDMI output signal.
Frame Line	On/Off	Turns the function to superimpose frame lines on the Monitor/HDMI output signal on/off.
Frame Line Select	Frame Line A/ Frame Line B	Selects the frame lines to display superimposed on the Monitor/HDMI output signal.

Monitoring > HDMI OSD

Makes settings related to information superimposed on the HDMI output signal.

Menu item	Settings	Description
OSD Status	Same as SDI/Same as Monitor	Selects whether the information displayed superimposed on the HDMI output signal is the same as for the SDI output signal or Monitor output signal.

Monitoring > Status Info A

Makes settings related to information displayed on the output image when Status Info Select is set to "Info. A" for each OSD menu item.

Menu item	Settings	Description
Project	On/Off	Turns the project information display on/off.
Timecode	On/Off	Turns the timecode information display on/off.
Audio Level Meter	On/Off	Turns the audio level meter indicators on/off.
Look Status	On/Off	Turns the Look type indicator on/off.
Output LUT	On/Off	Turns the output LUT information display on/off.
Recording LUT	On/Off	Turns the recording LUT information display on/off.
VF Status	On/Off	Turns the viewfinder status indicator on/off.
Lens Status	On/Off	Turns the lens information display on/off.

Monitoring > Status Info B

Makes settings related to information displayed on the output image when Status Info Select is set to "Info. B" for each OSD menu item.

Menu item	Settings	Description
Project	On/Off	Turns the project information display on/off.
Timecode	On/Off	Turns the timecode information display on/off.
Audio Level Meter	On/Off	Turns the audio level meter indicators on/off.
Look Status	On/Off	Turns the Look type indicator on/off.
Output LUT	On/Off	Turns the output LUT information display on/off.
Recording LUT	On/Off	Turns the recording LUT information display on/off.
VF Status	On/Off	Turns the viewfinder status indicator on/off.
Lens Status	On/Off	Turns the lens information display on/off.

Monitoring > Display Info

Makes settings related to focus position display units.

Menu item	Settings	Description
Focus Distance Format	Meter/ Feet	Selects the focus position display units.

Monitoring > Frame Line A

Makes settings related to information displayed on the output image when Frame Line is set to Frame Line A for each OSD menu item.

Menu item	Settings	Description
Center Marker	On/Off	Turns the center marker on/off.
Aspect Ratio	On/Off	Turns the aspect marker on/off.
Aspect Safety Zone	On/Off	Turns the aspect safety zone marker on/off.
Picture Area	On/Off	Turns the picture area indicator on/off.
Safety Zone	On/Off	Turns the safety zone indicator on/off.
User Frame Line	On/Off	Turns the user frame lines indicator on/off.

Monitoring > Frame Line B

Makes settings related to information displayed on the output image when Frame Line is set to Frame Line B for each OSD menu item.

Menu item	Settings	Description
Center Marker	On/Off	Turns the center marker on/off.
Aspect Ratio	On/Off	Turns the aspect marker on/off.
Aspect Safety Zone	On/Off	Turns the aspect safety zone marker on/off.
Picture Area	On/Off	Turns the picture area indicator on/off.
Safety Zone	On/Off	Turns the safety zone indicator on/off.
User Frame Line	On/Off	Turns the user frame lines indicator on/off.

Monitoring > Frame Line

Makes settings related to lines and markers displayed on the output image.

Menu item	Settings	Description
Color	White /Yellow/Cyan/Green/Magenta/Red/Blue	Selects the display color of frame lines.
Center Marker	Cross /Open Cross/Dot	Selects the display form of the center marker.
Safety Area	80%/90%/92.5%/95%	Selects the safety zone range.
Aspect Ratio Type	Line /Mask	Select the display form of the aspect marker. Line: Displays lines with color set by Color. Mask: Displays a lower video signal level for areas outside the marker area.
Aspect Ratio Select	17:9/ 16:9 /15:9/14:9/13:9/4:3/1.66:1/1.85:1/2.35:1/2.39:1	Selects the mode when displaying the aspect marker.
Aspect Ratio Mask	0 to 15 (12)	Selects the brightness of the image outside the aspect marker when Aspect Ratio Type is set to Mask.
Aspect Safety Area	80%/90%/92.5%/95%	Selects the size (percentage of the entire screen) of the aspect safety zone marker.
Frame Line on Playback	On /Off	Turns the function to superimpose frame lines during playback on/off.

Monitoring > User Frame Line

Makes settings related to the user frame lines.

Menu item	Settings	Description
Width	3 to 479 (240)	Sets the user frame line width (distance from the center to the left and right edges).
Height	3 to 269 (135)	Sets the user frame line height (distance from the center to the top and bottom edges).
H Position	Max. -476 to 476 (±0)	Sets the horizontal position of the center of the user frame lines. The setting range becomes narrower as the Width setting increases above 3.
V Position	Max. -266 to 266 (±0)	Sets the vertical position of the center of the user frame lines. The setting range becomes narrower as the Height setting increases above 3.

Monitoring > VF Display

Makes settings related to the viewfinder display.

Menu item	Settings	Description
VF LUT	Log/s709/R709(800%)	Selects the LUT to apply to the viewfinder output image.
Status Info	On /Off	Turns the function to superimpose information on the viewfinder output image on/off.

Monitoring > VF Display

Makes settings related to the viewfinder display.

Menu item	Settings	Description
Status Info Select	Info. A /Info. B	Selects the information to display superimposed on the viewfinder output image.
Frame Line	On/ Off	Turns the function to superimpose frame lines on the viewfinder output image on/off.
Frame Line Select	Frame Line A /Frame Line B	Selects the frame lines to display superimposed on the viewfinder output image.
Color	-99 to ±0 to +99	Adjusts the color depth of the viewfinder image.

Monitoring > VF Function

Makes settings related to viewfinder functions.

Menu item	Settings	Description
Double Speed Scan	On/ Off	Turns the viewfinder double speed scan function on/off.
Peaking Frequency	Normal /High	Selects whether the peaking frequency is normal or high during peaking.
Zebra	On/ Off	Turns the zebra function on/off.
Zebra Select	1/2 /Both	Selects the zebra pattern type (Zebra 1, Zebra 2, Both).
Zebra1 Level	0% to 107% (41%)	Sets the display level of zebra 1.
Zebra1 Aperture Level	1% to 20% (10%)	Sets the aperture level of zebra 1.
Zebra2 Level	0% to 109% (61%)	Sets the display level of zebra 2.

Audio Menu

Default values are shown underlined and in **bold** text.

Audio > Audio Input

Makes settings related to audio recording levels.

[Note]

The audio recording level with AES/EBU signal selected is fixed.

Menu item	Settings	Description
CH-1 Audio Select	<u>Auto</u> /Manual	Automatically adjusts the audio recording when set to Auto.
CH-2 Audio Select	<u>Auto</u> /Manual	Automatically adjusts the audio recording when set to Auto.
CH-1 Audio Level	-99 to <u>±0</u> to +99	Adjusts the audio recording level when CH-1 Audio Select is set to Manual.
CH-2 Audio Level	-99 to <u>±0</u> to +99	Adjusts the audio recording level when CH-2 Audio Select is set to Manual.
MIC Reference	-60dB/ <u>-50dB</u> /-40dB	Selects the reference input level of the microphone.

Audio > Audio Monitor

Makes settings related to audio monitoring.

Menu item	Settings	Description
Monitor CH	When Monitor Output CH Pair is set to CH-1/CH-2 <u>CH-1/CH-2</u> , CH-1, CH-2 When Monitor Output CH Pair is set to CH-3/CH-4 <u>CH-3/CH-4</u> , CH-3, CH-4	Selects the audio channel that is output to the headphones and speaker. CH-1/CH-2 (CH-3/CH-4): Channel 1+2 (Channel 3+4) CH-1 (CH-3): Channel 1 (Channel 3) only CH-2 (CH-4): Channel 2 (Channel 4) only
Monitor Level	<u>0</u> to 99	Adjusts the monitor audio level.

Audio > Audio Configuration

Makes settings related to audio input/output.

Menu item	Settings	Description
Input Limiter Mode	<u>Off</u> /-6dB/-9dB/-12dB/-15dB/-17dB	Selects the limiter characteristic (saturation level) for large input signals when adjusting the audio input level manually. Select Off if not using the limiter.
AGC Level	<u>-6dB</u> /-9dB/-12dB/-15dB/-17dB	Selects the AGC characteristic (saturation level).
AGC Mono/Stereo	Mono/ <u>Stereo</u>	Automatically adjusts the input level of analog audio signals recorded on channels 1 and 2, and selects whether to make the adjustments separately for each channel (Mono) or in stereo mode (Stereo).

Audio > Audio Configuration

Makes settings related to audio input/output.

Menu item	Settings	Description
MIC Input Mono/Stereo	Mono/ <u>Stereo</u>	Selects whether the front microphone is monaural (Mono) or stereo (Stereo).
Phantom Power +48V	<u>On</u> /Off	Turns the function to supply a +48 V external source (phantom power) to the microphone on/off.
Monitor Output CH Pair	<u>CH-1/CH-2</u> , CH-3/CH-4	Sets the audio output channels to either channels 1 and 2 or channels 3 and 4.
Headphone Mono/ST	<u>Mono</u> /Stereo	Sets the headphones output to monaural (Mono) or stereo (Stereo).

Technical Menu

Default values are shown underlined and in **bold** text.

Technical > Test Signals		
Makes settings related to color bars.		
Menu item	Settings	Description
Color Bars	On/ <u>Off</u>	Turns color bars on/off.
Color Bars Type	<u>ARIB</u> /SMPTE	Selects the type of color bars.
1KHz Tone on Color Bars	On/ <u>Off</u>	Turns the function to output a 1 kHz test signal in color bars mode on/off.
Test Saw	On/ <u>Off</u>	Turns the test signal on/off.
Technical > Switch & Rec Light		
Makes settings related to the REC button.		
Menu item	Settings	Description
Lock Operator Side	<u>without Rec Button</u> /with Rec Button	Sets whether to lock the REC button operation when buttons are locked using the LOCK switch on the Operator side.
Lock Assistant Side	<u>without Rec Button</u> /with Rec Button	Sets whether to lock the REC button operation when buttons are locked using the LOCK switch on the Assistant side.
Rec Light	<u>On</u> /Off	Turns the REC lamp on/off.
Rec Start/Stop Beep	On/ <u>Off</u>	Turns the function to emit a beep sound when recording starts and stops on/off.
Technical > System Configuration		
Makes settings related to control of the unit.		
Menu item	Settings	Description
Fan Control	Auto/Max/ <u>Off in Rec/Auto</u> / Off in Rec/Max	Selects the fan control mode. Auto: Controls the fan automatically in response to the internal temperature. Max: Fan rotates at maximum speed. Off in Rec/Auto: The fan is silent when recording, and operates automatically in response to the internal temperature when not recording. Off in Rec/Max: The fan is silent when recording, and rotates at maximum speed when not recording.
Lens Interface	<u>Type C</u> /Off	Sets the lens interface, before attaching a lens, according to the lens type to attach. [Note] If changing this setting while the lens is attached to the unit, turn the turn off and then on again.

Technical > System Configuration		
Makes settings related to control of the unit.		
Menu item	Settings	Description
SDI Rec Remote Trigger	<u>Off</u> /HD SDI Remote I/F/Parallel Rec	Selects the SDI remote mode control method. Off: Disables remote control. HD SDI Remote I/F: Uses HD SDI Remote control method. Parallel Rec: Uses valid flag control method.
SD HDMI	On/ <u>Off</u>	Turns the function to set the HDMI output signal to SD format on/off.
Shutter Mode	Speed/ <u>Angle</u>	Selects the operating mode of the electronic shutter.
Technical > APR		
Executes APR (Auto Pixel Restoration: auto adjustment of the image sensor).		
Menu item	Settings	Description
APR	Execute/Cancel	Executes the automatic pixel noise reduction function (execute by selecting Execute).
Reset	Execute/Cancel	Deletes white flecks added by execution of the APR and automatic black balance adjustment functions (execute by selecting Execute).
Technical > Battery		
Makes settings related to batteries.		
Menu item	Settings	Description
Near End:Info Battery	<u>5%</u> to 100% (5% increments)	Sets the threshold value at which the remaining battery capacity indicator starts flashing when using an InfoLithium battery.
End:Info Battery	<u>0%</u> to 5%	Sets the threshold value for displaying the "Battery End" warning when using an InfoLithium battery.
Near End:Sony Battery	<u>11.5V</u> to 17V (0.1V increments)	Sets the threshold value at which the remaining battery capacity indicator starts flashing when using a Sony non-InfoLithium battery.
End:Sony Battery	<u>11.0V</u> to 11.5V (0.1V increments)	Sets the threshold value for displaying the "Battery End" warning when using a Sony non-InfoLithium battery.
Near End:Other Battery	11.5V to 17V (<u>11.8V</u>) (0.1V increments)	Sets the threshold value at which the remaining battery capacity indicator starts flashing warning when using a non-Sony battery.
End:Other Battery	<u>11.0V</u> to 14V (0.1V increments)	Sets the threshold value for displaying the "Battery End" warning when using a non-Sony battery.
Detected Battery	Sony Info Battery/Sony Battery/ Other Battery/DC IN (12V)/DC IN (24V)	Displays the result of automatic battery pack type detection.

Technical > DC Voltage Alarm Sets alarms relating to external DC supply voltage.		
Menu item	Settings	Description
DC Low Voltage1	<u>11.5V</u> to 17V (0.1V increments)	Sets the threshold value for displaying a low voltage warning when using an external power source connected to the DC IN connector.
DC Low Voltage2	<u>11.0V</u> to 14V (0.1V increments)	Sets the threshold value for displaying an undervoltage warning when using an external power source connected to the DC IN connector.
DC(24V) Low Voltage1	<u>22.5V</u> to 34.0V (0.1V increments)	Sets the threshold value for displaying a low voltage warning when using a 24 V external power source connected to the DC IN connector.
DC(24V) Low Voltage2	<u>22.0V</u> to 28.0V (0.1V increments)	Sets the threshold value for displaying an undervoltage warning when using a 24 V external power source connected to the DC IN connector.
Technical > Control Display Makes settings related to the displays.		
Menu item	Settings	Description
Brightness level	<u>High</u> /Mid/Low/Minimum	Adjusts the brightness of the sub display and mini display.
Technical > Genlock Makes settings related to genlock.		
Menu item	Settings	Description
Input Source	<u>HD SDI</u> /Analog	Selects the genlock input signal. HD SDI: Digital Analog: Analog
Reference Lock Type	Internal/External(HD)/ External(SD)	Displays the genlock status. Displays the signal type when genlocked. Internal: Not genlocked. External(HD): Genlocked by the HD signal. External(SD): Genlocked by the SD signal.

Maintenance Menu

Default values are shown underlined and in **bold** text.

Maintenance > Clock Set Makes settings related to the built-in clock.		
Menu item	Settings	Description
Time Zone	UTC + 14:00 to <u>UTC Greenwich</u> to UTC – 12:00 (30-minute increments)	Selects the difference in time from UTC (Greenwich Mean Time) in units of 30 increments.
Date Mode	<u>YYMMDD</u> /MMDDYY/DDMMYY	Selects the display format for dates. YYMMDD: Year, month, day MMDDYY: Month, day, year DDMMYY: Day, month, year
Date		Sets the current date (apply by pressing Set).
Time		Sets the current time (apply by pressing Set).
Maintenance > Language Selects the display language for menus and messages.		
Menu item	Settings	Description
Select	English/ <u>中文(简)</u>	Selects the display language for the full menu and messages.
Maintenance > Hours Meter Displays the accumulated usage time.		
Menu item	Settings	Description
Camera(System)		Displays the accumulated time of use of the unit (cannot be reset).
R7 Recorder (System) (Only when an AXS-R7 is attached)		Displays the accumulated time of use of the AXS recorder connected to the unit (cannot be reset).
Camera(Resettable)		Displays the accumulated time of use of the unit (can be reset).
R7 Recorder (Resettable) (Only when an AXS-R7 is attached)		Displays the accumulated time of use of the AXS recorder connected to the unit (can be reset).
Reset-Cam (Resettable)	Execute/Cancel	Resets the Camera(Resettable) display to 0 (execute by selecting Execute).
Reset-R7 (Resettable) (Only when an AXS-R7 is attached)	Execute/Cancel	Resets the R7 Recorder(Resettable) display for the AXS recorder connected to the unit to 0 (execute by selecting Execute).

Maintenance > Reset to Default		
Returns the unit to factory default state.		
Menu item	Settings	Description
Reset	Execute/Cancel	Initializes all unit settings (execute by selecting Execute).
Maintenance > License Options		
Installs software options.		
Menu item	Settings	Description
Install: <target_license>	Execute/Cancel	Installs software options (execute by selecting Execute).
Anamorphic	Permanent License Installed/ XX days Remaining (YY keys)/ Expired/Not Installed	Displays whether the Anamorphic option is enabled. Permanent License Installed: Permanent license is installed XX days Remaining (YY keys): Expiration of timed license Expired: Timed license has expired Not Installed: Not installed
Full Frame	Permanent License Installed/ XX days Remaining (YY keys)/ Expired/Not Installed	Displays whether the Full Frame option is enabled. Permanent License Installed: Permanent license is installed XX days Remaining (YY keys): Expiration of timed license Expired: Timed license has expired Not Installed: Not installed
Unique Device ID		Displays the ID used for issuing the software option license key.
Maintenance > Firmware		
Displays the version of the unit and AXS recorder, and updates the unit.		
Menu item	Settings	Description
Camera		Displays the firmware version of the unit (Vx.xx).
AXS (Only when an AXS-R7 is attached)		Displays the firmware version of the AXS recorder connected to the unit (Vx.xx).
FW Update-camera	Execute/Cancel	Updates the unit (execute by selecting Execute).

Clip Operations

Clip operations are performed using the clip list screen and the playback screen. You can play a clip by selecting the clip to play from the clip list screen displayed on the sub display.

When AXS Rec Format is not set to Rec Off in the Project category in the menu, AXS media becomes playable. Similarly, when SxS Rec Format is not set to Rec Off, SxS media becomes playable.

Clip List Screen

Press the CLIPS button (page 8) on the Assistant side to display the clip list screen for playable media on the sub display.

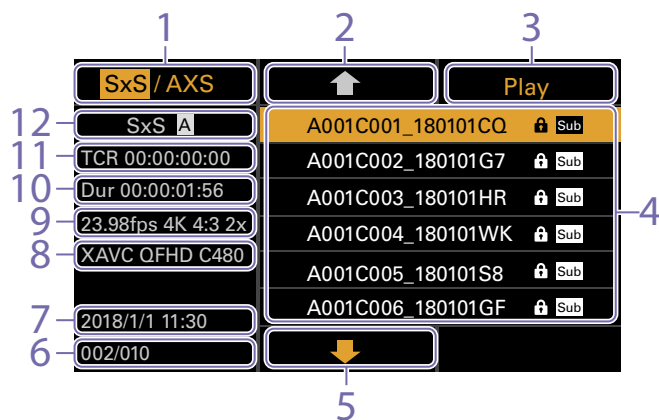

1. Media select button

Displays "SxS/AXS" if both SxS and AXS media are playable. Press ITEM key 1 to switch the playback media.

2. Cursor up button

Press ITEM key 2 to select the clip to play from the clip list.

3. Playback start button

Press ITEM key 3 to display the playback screen (page 13) and start playback.

4. Clip list

Displays a list of clips on the active playback media. It also displays the clips status using icons.

Icon	Meaning
Sub	Clip with a created sub clip
🔒	Locked (write protection) clip

5. Cursor down button

Press ITEM key 5 to select the clip to play from the clip list.

6. Clip position in playback media

Displays the number of the clip indicated by the cursor and total number of clips.

7. Creation date and time

Displays the creation date and time of the clip indicated by the cursor.

8. Format (codec)

Displays the recording format (codec) of the clip indicated by the cursor.

9. Project frame rate/picture size indicator

Displays the project frame rate and picture size of the clip indicated by the cursor.

10. Duration (Dur)

Displays the duration of the clip indicated by the cursor.

11. Timecode (TCR)

Displays the timecode of the first frame of the clip indicated by the cursor.

12. Active playback media

Displays the active playback media of the displayed list.

Playback Screen

The playback screen is displayed when you select a clip to play on the clip list screen and press the MENU dial or Play button (ITEM key 3).

Function display area



1. F Rev button

Play back at high speed in the reverse direction.

2. Play/Pause button

Play a clip or pause playback.

3. F Fwd button

Play back at high speed in the forward direction.

4. Prev button

Skip to the start of the previous clip.

5. Stop/Clips button

Stop playback and return to the clip list screen.

6. Next button

Skip to the start of the next clip.

Status display area

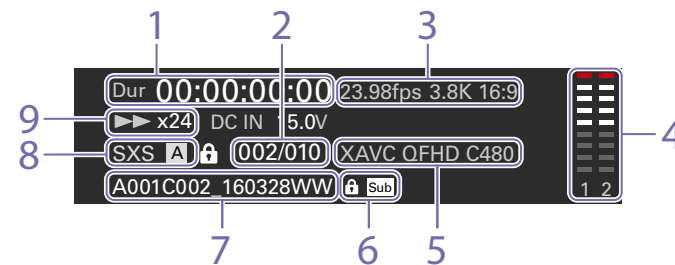

1. Time data display

Displays the timecode of the playback position.

2. Clip number

Displays the Current playback clip number/ Total number of playable clips.

3. Frame rate/imager mode indicator

Displays the project frame rate and picture size.

4. Audio level meters

Displays the playback audio level.

5. Playback clip format (codec) indicator

Displays the format (codec) of the playback clip.

6. Icon display

Displays the clip status using icons.

7. Clip name indicator

Displays the name of the clip.

8. Media indicator

Displays the media being played.

9. Playback status indicator

Displays the playback status.



Icon	Meaning
Sub	Clip with a created sub clip
🔒	Locked (write protection) clip

Playback

You can play recorded clips while the unit is in standby mode.

[Note]

The playback controls appear on ITEM keys 1 to 6 (page 7). Press an ITEM key to select the corresponding item.

- 1 Insert the SxS memory card to play .
- 2 Press the CLIPS button (page 8) on the Assistant side.
The clip list on the active playback media appears on the sub display.
- 3 Press the  button (ITEM key 2),  button (ITEM key 5), or MENU dial to select a clip to play.
- 4 Press the MENU dial or the Play button (ITEM key 3).
The playback image appears on the viewfinder screen.



Playback operations

Playback operation is performed using the buttons on the sub display (page 53).

Play/Pause button: Pause playback. To resume playback, press this button again.

F Fwd button/F Rev button: Fast forward/reverse.
To return to normal playback, press the Play/Pause button.

Stop/Clips button: Stop playback and return to the clip list screen.

Monitoring audio

In normal playback mode, you can monitor the recorded audio through the built-in speaker (page 6) or connected headphones.

When headphones are connected to the headphones connector (page 6), the built-in speaker is turned off.

You can select the channel to monitor and adjust the volume using Audio category > Monitor CH and Monitor Level (page 38) in the menu.

Cueing up

To play from the start of a clip, press the Prev button on the sub display (page 27).

You can skip clips and cue-up another clip by pressing the Prev button or Next button repeatedly.

Switching the SxS memory cards

When two SxS memory cards are loaded, press the SLOT SELECT button (page 7) to switch memory cards.

[Note]

You cannot switch SxS memory cards during playback. Continuous playback of cards in slots A and B is not possible.

Switching to an AXS memory card

You can quickly play video recorded on an AXS memory card in the AXS-R7.

To switch to an AXS memory card, press ITEM key 1 (page 27) on the sub display.

The playback signal is output from the output connector of the unit.

Operations on the Home Screen of the Mini Display

You can check the status of the unit and set basic settings for the unit on the Home screen of the mini display.

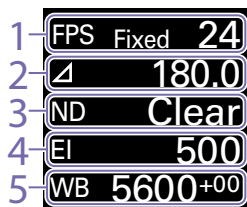

1. **FPS**
Displays the video frame rate.
2. **Shutter**
Displays and sets the shutter speed/shutter angle of the electronic shutter.
3. **ND Filter**
Displays and sets the density of the ND filter.
4. **Exposure Index**
Displays and sets the exposure index (EI).
5. **WB (White Balance)**
Displays and sets the white balance.

Controls

HOME button (page 6)

Press to return to the Home screen. Unconfirmed changes are canceled.

ITEM key 1 (↑) (page 6)

Press to select items on the Home screen.

ITEM key 2 (●) (page 6)

Press to apply the selected item.

ITEM key 3 (↓) (page 6)

Press to select items on the Home screen.

Basic Operation

- 1 Press ITEM key 1, 2, or 3.
The cursor appears.
- 2 Select the item to set using the ↑ button (ITEM key 1) or ↓ button (ITEM key 3).

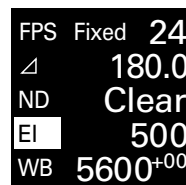

- 3 Press the ● button (ITEM key 2).
The setting value selection screen appears for the selected item.

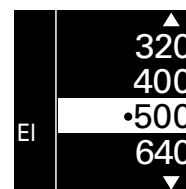

[Note]

The ● mark indicates the current setting.

- 4 Move the cursor to the item or setting value using the ↑ button (ITEM key 1) or ↓ button (ITEM key 3).
- 5 Press the ● button (ITEM key 2) to apply the setting.
- 6 Press the HOME button to hide the cursor.

Home Screen Items on the Mini Display

The names of items and corresponding setting values are given below.
Default values are shown underlined and in **bold** text.

Item	Description														
FPS	Displays the video frame rate. The setting is determined by the Project category > Project Frame Rate setting (page 36) in the menu.														
	<table border="1"> <thead> <tr> <th>Project Frame Rate</th> <th>Display</th> </tr> </thead> <tbody> <tr> <td>23.98</td> <td>Fixed 24</td> </tr> <tr> <td><u>24</u></td> <td>Fixed 24</td> </tr> <tr> <td>25</td> <td>Fixed 25</td> </tr> <tr> <td>29.97</td> <td>Fixed 30</td> </tr> <tr> <td>50</td> <td>Fixed 50</td> </tr> <tr> <td>59.94</td> <td>Fixed 60</td> </tr> </tbody> </table>	Project Frame Rate	Display	23.98	Fixed 24	<u>24</u>	Fixed 24	25	Fixed 25	29.97	Fixed 30	50	Fixed 50	59.94	Fixed 60
Project Frame Rate	Display														
23.98	Fixed 24														
<u>24</u>	Fixed 24														
25	Fixed 25														
29.97	Fixed 30														
50	Fixed 50														
59.94	Fixed 60														
Exposure Index	Sets the EI value. The following settings are available. 125EI/160EI/200EI/250EI/320EI/400EI/ <u>500EI</u> /640EI/800EI/1000EI/ 1250EI/1600EI/2000EI														
Shutter	Sets the electronic shutter angle/shutter speed. Select from preset values registered as shutter steps. [Note] Not available when the electronic shutter operation is set to Continuous. Displays the following selection options depending on the Technical > System Configuration > Shutter Mode (page 49) setting in the full menu. Angle (Δ): Shutter angle indicator 360.0/ <u>180.0</u> /172.8/144.0/90.0/45.0/22.5/11.2 ¹⁾ Speed (SS): Shutter speed indicator 1/24, 1/25, 1/30, 1/50, 1/60, 1/100, 1/120, 1/250, 1/500, 1/1000, 1/2000 ¹⁾														
ND Filter	Sets the density of the ND filter. The following settings are available. <u>Clear</u> /0.3/0.6/0.9/1.2/1.5/1.8/2.1/2.4														
WB (White Balance)	Sets the color temperature of the white balance. Select from preset values registered as WB steps. <u>3200K+00</u> /4300K+00/5500K+00 ¹⁾														

¹⁾ The selection options can be changed using Step Edit on the Home screen of the sub display.

Basic Operations

Basic recording can be performed with the following procedures.

- 1 Make sure that the necessary devices are attached to the unit and power is supplied to them.
- 2 Set the power switch (page 6) to the ON position.
The recording screen is displayed on the viewfinder screen.
- 3 Load the memory card(s).
If you load two SxS memory cards, recording is continued by automatically switching to the second card when the first card becomes full.
- 4 Press the REC button (pages 6, 8).
The REC lamp lights and recording begins.

[Note]

If the unit cannot start recording immediately after the pressing the REC button, the REC lamp flashes. The REC lamp lights when recording starts.
- 5 To stop recording, press the REC button again.
Recording stops and the unit enters STBY (recording standby) mode.
When you stop recording, the video, audio, and subsidiary data from the start to the end of the recording are recorded as a single clip.

Clip names

Clip names are recorded using the "Cam ID + Reel#" format. The clip name is created according to the following rules.

- When there is already a clip that is stored using the "Cam ID + Reel#" name format on the inserted SxS memory card or AXS memory card, the new file inherits from the last file.
Example: If "B002C003_XXXXXXXX" exists on the AXS memory card, the next created clip will be named "B002C004_XXXXXXXX."
- If the inserted AXS memory card has no files, "1" is added to the Reel Number of the clip that was recorded last.
Example: If you record on empty card 2 after recording up to "D001CXXX_XXXXXXXX" on card 1, the next created clip will be named "D002C001_XXXXXXXX." The clip name flashes until recording starts.
- If you set Camera ID and Reel Number using TC/Media category > Clip Naming in the menu, that information is applied.
Example: If you change Camera ID to "F" and Reel Number to "001" in the menu for the AXS memory card that has recorded up to "E003CXXX_XXXXXXXX," the next clip will be named "F001CXXX_XXXXXXXX." When you change Camera ID only, Reel Number is changed to "001."

Maximum duration of a clip

The maximum single clip length that you can record to an SxS memory card is 6 hours. Recording stops if the recording time exceeds the maximum clip duration.

Useful Functions

Simultaneous Recording (Simul Rec)

You can simultaneously record two sizes of pictures on an SxS memory card in one slot. You can also simultaneously record an HD signal on an SxS memory card in the unit while recording video and audio in RAW format on the AXS-R7.

You can perform simultaneous recording using Project category > AXS Rec Format and SxS Rec Format or SxS Rec Format and Sub Rec Format in the menu as described in "Recording Format Settings" (page 39).

[Note]

In simultaneous recording mode, the unit cannot switch to the second card automatically even if a card becomes full.

In 1-slot simultaneous recording, the XAVC 4K Class480/XAVC 4K Class300/XAVC QFHD Class480/XAVC QFHD Class300 clip is recorded in the XDROOT/Clip directory on the SxS memory card, but the MPEG2 1920×1080 clip is recorded in the XDROOT/Sub directory on the SxS memory card. The suffix "S02" is appended to the end of the clip name.

Recording Review (Rec Review)

You can review the last recorded clip on the screen by assigning the Rec Review function to one of assignable buttons 1 to 4 (page 32).

When you stop recording and press the button assigned with Rec Review, the clip is played at normal speed starting from the first frame.

The clip is played to the end, then Rec Review ends and the unit returns to STBY (recording standby) mode.

If the HOME button is pressed on the Operator side or Assistant side during playback, playback stops and the unit switches to shooting mode.

Focus Magnifier Function

By pressing the FOCUS MAG button of the viewfinder (DVF-EL200, DVF-L700) attached to the unit, you can expand the center part of the viewfinder, making it is easier to adjust the focus. After adjusting the focus, press the button again to return to the normal (recording) screen. The magnified display does not affect the recorded image or output signal.

Viewfinder Double Speed Scan Function

If the project frame rate is 23.98P, 24P, 25P, or 29.97P, the image may become blurred and hard to see due to low frame frequency when you shoot while swaying the unit to the right and the left.

In this case, you can decrease image blur and make it easier to see by activating the viewfinder double speed scan function.

To activate the function, set Monitoring category > Moni. Details > VF Function > Double Speed Scan (page 47) in the menu to On.

[Note]

When this function is activated, the shutter angle of the electronic shutter function is limited to 180 degrees or lower.

Connecting External Monitors and Recording Devices

To display the recording/playback image on an external monitor, select the output signal and use an appropriate cable for the monitor to be connected.

The output signal from the unit can be recorded by connecting a recording device, such as a VTR. The same status information and menus can be displayed on the external monitor as those on the viewfinder screen. Set the content to display, according to the output signal for the monitor, using the Monitoring menu (page 45).

SDI OUT Connector (BNC Type)

Set the output format using the Monitoring menu (page 45).

Use a commercially available 75-ohm coaxial cable for connection.

[Note]

Check that the ground connection between the unit and external device is securely grounded before turning the power on. (We recommend turning on the unit and external device after connecting a 75-ohm coaxial cable.) When connecting an external device to the unit while the unit is turned on, connect to the unit after connecting a 75-ohm coaxial cable to the external device.

To start synchronized recording on an external device

With SDI signal output selected, synchronized recording is possible by feeding a REC trigger signal to an external recording device connected to the SDI OUT connector. Enable synchronized recording by setting Technical > System Configuration > SDI Rec Remote Trigger (page 49) in the menu to HD SDI Remote I/F or Parallel Rec.

[Note]

When a connected external device does not support a REC trigger signal, the device cannot be operated.

MONITOR OUT Connector (BNC Type)

Outputs an HD SDI signal.

Set the output format using the Monitoring menu (page 45).

Use a commercially available 75-ohm coaxial cable for connection.

HDMI OUT Connector (Type A Connector)

Set the output format using the Monitoring menu (page 45).

Use a commercially available HDMI cable for connection.

If the output format has the same resolution as the MONITOR OUT connector signal, the same video signal is output.

12V OUT Connector (DC OUT 12V, Hirose 4-pin)

Supplies 12 V DC power to an accessory when the power switch is set to ON. You can output a REC Tally signal and input a REC Trigger signal through the 12V OUT connector.

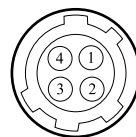

No.	Signal	I/O	Specification
1	UNREG GND	–	GND for UNREG
2	REC TALLY	OUT	Open-collector output (Max. 50 mA) Low: REC
3	REC TRIGGER	IN	Open or +5 V DC: Normal GND: Active (REC)
4	UNREG +12 V OUT	OUT	+11 V to 17 V DC output 11 V to 17 V input Output voltage: Same as the input voltage Maximum output current: 1.0 A 22 V to 32 V input Output voltage : 15 V Maximum output current: 0.8 A

24V OUT Connector (DC OUT 24 V, Fischer 3-pin)

Supplies 24 V DC power to an accessory when the power switch is set to ON. You can output a REC Tally signal and input a REC Trigger signal through the 24V OUT connector.

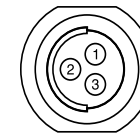

No.	Signal	Specification
1	GND	
2	24V-AUX	11 V to 17 V input Output voltage : 24 V Maximum output current: 1.0 A 22 V to 32 V input Output voltage: Same as the input voltage Maximum output current: 2.0 A
3	R/S	

AUX Connector (LEMO 5-pin)

Outputs the timecode signal.

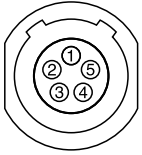

No.	Signal
1	Factory Use
2	NC
3	-
4	TC OUT
5	GND

External Synchronization

When shooting with multiple units, synchronized recording can be performed using a specific reference signal to synchronize the timecode among all the units.

Synchronizing the Phase of the Video Signal (Genlock)

Genlock operation is enabled by supplying one of the following reference signals to the GENLOCK IN connector (page 9) of the unit.

- HDSDI 1.5G digital I (Interlaced or PsF)
- HD Y analog
- SD VBS analog

Set the genlock input signal using Technical > Genlock > Input Source (page 50) in the full menu.

Valid input reference signals vary depending on the project frame rate setting.

Project frame rate	Valid reference signal
23.98P	1920×1080 47.95i (23.98PsF)
24P	1920×1080 48i (24PsF)
25P	1920×1080 50i 720×576 50i
29.97P	1920×1080 59.94i 720×486 59.94i
50i	1920×1080 50i 720×576 50i
50P	1920×1080 50i 720×576 50i
59.94i	1920×1080 59.94i 720×486 59.94i
59.94P	1920×1080 59.94i 720×486 59.94i

You can check the genlock status using Technical > Genlock > Reference Lock Type (page 50) in the menu.

[Notes]

- If the reference signal is unstable, genlock is not possible.
- The subcarrier is not synchronized.

Synchronizing the Timecode with Another Device

Set the unit that supplies the timecode to a mode in which the timecode output keeps advancing (Free Run mode).

- 1 Set TC/Media > Timecode > Mode (page 44) in the menu to Preset F-Run (Ext-Lk).
- 2 Supply an HD or SD reference video signal to the GENLOCK IN connector (page 9) and a reference timecode synchronized with that signal to the TC IN (page 9) connector.

The built-in timecode generator of your unit locks to the reference timecode, and the message "Ext-Lk" is displayed on the screen. Once about ten seconds have elapsed after the timecode locks, the external lock state is maintained even if the external timecode source is disconnected.

[Notes]

- Check that the reference timecode and the reference video signal are in a phase relationship that complies with the SMPTE timecode standards.
- When you finish the above procedure, the timecode is immediately synchronized with the external timecode, and the time data indication will show the value of the external timecode. However, wait for a few seconds until the timecode generator stabilizes before recording.
- If the frequency of the reference video signal and the frame frequency are not the same, lock cannot be acquired, and the unit will not operate properly. If this occurs, the timecode will not acquire successful lock with the external timecode.
- When the connection is removed, the timecode advance may shift one frame per hour with respect to the reference timecode.

To release external lock

Change the TC/Media > Timecode > Mode (page 44) setting in the menu.

Usage Precautions

Read this section in conjunction with the information provided in the supplied "Before Using this Unit" document.

Use and Storage

Do not subject the unit to severe shock

The internal mechanism may be damaged or the body warped.

Do not cover the unit while operating

Putting a cloth, for example, over the unit can cause excessive internal heat build-up.

After use

Always set the power switch to OFF.

Before storing the unit for a long period

Remove the battery pack.

Do not leave the unit with the lens facing the sun

Direct sunlight can enter through the lens, be focused in the unit, and cause fire.

Shipping

- Remove the memory cards before transporting the unit.
- If sending the unit by truck, ship, air or other transportation service, pack it in the shipping carton of the unit.

Care of the Unit

If the body of the unit is dirty, clean it with a soft, dry cloth. In extreme cases, use a cloth moistened in a little neutral detergent, then wipe dry. Do not use organic solvents, such as alcohol or thinners, as these may cause discoloration or other damage to the finish of the unit. Refrain from cleaning with high air pressure equipment, such as an air duster, as these may damage optical components.

In the event of operating problems

If you should experience problems with the unit, contact your Sony dealer.

Periodic Replacement of Fan and Battery

The fan and battery are consumable parts that will need periodic replacement.

When operating at room temperature, a normal replacement cycle will be about 5 years. However, this replacement cycle represents only a general guideline and does not imply that the life expectancy of these parts is guaranteed. For details on parts replacement, contact your dealer.

Life Expectancy of the Electrolytic Capacitor

The life expectancy of the electrolytic capacitor is about 5 years under normal operating temperatures and normal usage (8 hours per day; 25 days per month).

If usage exceeds the above normal usage frequency, the life expectancy may be reduced correspondingly.

Note about the Battery Terminal

The battery terminal of this unit (the connector for battery packs and AC adaptors) is a consumable part.

Power may not be supplied to the unit properly if the pins of the battery terminal are bent or deformed by shock or vibrations, or if they become corroded due to prolonged outdoor use. Periodic inspections are recommended to keep the unit working properly and to prolong its usable lifetime.

Contact a Sony service or sales representative for more information about inspections.

Use and Storage Locations

Store in a level, ventilated place.

Avoid using or storing the unit in the following places.

- In excessive heat or cold (operating temperature range: 0 °C to 40 °C (32 °F to 104 °F))
Remember that in summer in warm climates the temperature inside a car with the windows closed can easily exceed 50 °C (122 °F).
- In damp or dusty locations
- Locations where the unit may be exposed to rain
- Locations subject to violent vibration
- Near strong magnetic fields
- Close to radio or TV transmitters producing strong electromagnetic fields.
- In direct sunlight or close to heaters for extended periods

To prevent electromagnetic interference from portable communications devices

The use of portable telephones and other communications devices near this unit can result in malfunctions and interference with audio and video signals.

It is recommended that the portable communications devices near this unit be powered off.

Note on laser beams

Laser beams may damage the CMOS image sensor. If you shoot a scene that includes a laser beam, be careful not to let the laser beam be directed into the lens of the unit. Specifically, high-power laser beams from medical devices or other devices may cause damage due to reflected light and scattered light.

About the Screens

- Do not leave the screens facing direct sunlight, as this may damage the screens.
- Do not press/swipe the screens forcefully, or leave objects on the screens, as it may cause a malfunction, such as picture irregularity, etc.
- The screens may become warm in use. This is not a malfunction.

LCD and OLED Panels

The LCD panel fitted to this unit is manufactured with high precision technology, giving a functioning pixel ratio of at least 99.99%. Thus a very small proportion of pixels may be “stuck”, either always off (black), always on (red, green, or blue), or flashing. In addition, over a long period of use, because of the physical characteristics of the liquid crystal display, such “stuck” pixels may appear spontaneously.

These problems are not a malfunction.

Note that any such problems have no effect on recorded data.

The OLED (organic light emitting diode) panel of this unit may also exhibit “stuck” pixels and/or bright spots. These problems are not a malfunction.

On Condensation

If the unit is suddenly taken from a cold to a warm location, or if ambient temperature suddenly rises, moisture may form on the outer surface of the unit and/or inside of the unit. This is known as condensation. If condensation occurs, turn off the unit and wait until the condensation clears before operating the unit. Operating the unit while condensation is present may damage the unit.

Phenomena Specific to CMOS Image Sensors

The following phenomena that may appear in images are specific to CMOS (Complementary Metal Oxide Semiconductor) image sensors. They do not indicate malfunctions.

White flecks

Although the CMOS image sensors are produced with high-precision technologies, fine white flecks may be generated on the screen in rare cases, caused by cosmic rays, etc. This is related to the principle of image sensors and is not a malfunction.

The white flecks especially tend to be seen in the following cases.

- When operating at high environmental temperatures

Aliasing

When fine patterns, stripes, or lines are shot, they may appear jagged or flicker.

Focal plane

Owing to the characteristics of the pickup elements (CMOS sensors) for reading video signals, subjects that quickly move across the screen may appear slightly skewed.

Flashbanding

The luminance at the top and bottom of the screen may change when shooting a flashlight beam or a light source that quickly flashes.

Flicker

If recording is made under lighting produced by discharge tubes, such as fluorescent, sodium, or mercury-vapor lamps, the screen may flicker, colors may vary, or horizontal stripes may appear distorted.

Notes on the Display

- Pictures on the viewfinder screen may be distorted by the following operations.
 - Changing the video format
- When you change the line of sight in the viewfinder, you may see primary colors red, green, and blue, but this is not a defect of the unit. These primary colors are not recorded on any recording media.

Fragmentation

If pictures cannot be recorded/reproduced properly, try formatting the recording medium. While repeating picture recording/playback with a certain recording media for an extended period, files in the media may be fragmented, disabling proper recording/storage. In such a case, make a backup of clips in the media then perform formatting of the media using TC/Media > Format Media (page 44) in the menu.

Output Voltages of the Unit

The total output power that can be supplied to peripheral devices from the unit varies depending on the input voltage to the unit and the state of the connected accessories. The maximum output capacity ratings of the following connectors that can supply power may not be achieved depending on the conditions.

LENS connector: 1 A max.

12V OUT connector (4-pin):

0.8 A max. (Input voltage: 22 V to 32 V)

1 A max. (Input voltage: 11 V to 17 V)

24V OUT connector (3-pin):

2 A max. (Input voltage: 22 V to 32 V)

1 A max. (Input voltage: 11 V to 17 V)

When an AXS-R7 and DVF-EL200 are attached and the input voltage to the unit is 14 V or lower, the power rating available for peripheral devices is limited.

Total power rating of peripheral devices: Y [W]

Voltage of power supply to the unit: X [V]

Power consumption of the unit: Approx. 60 W

Power consumption of the AXS-R7:

Approx. 24 W

Power consumption of the DVF-EL200:

Approx. 2.5 W

$Y [W] = X [V] \times 9.0 [A]^1 - (60 + 24 + 2.5) [W]$

When supplying power from the unit to peripheral devices, make sure that the total power requirement does not exceed the total power rating given by the equation above.

(Note that the equation does not apply if the calculated result exceeds the sum of the maximum allowable output power of each power output connector.)

¹⁾ 6.0 [A] when using the AC-DN10.

Recording Formats and Output Signals

SDI OUT Connector Output Formats

The serial digital signal from an SDI OUT connector is output according to the Project category and Monitoring category settings in the menu. For details about Project category settings combinations, see "Recording Format Settings" (page 39).

Default values are shown underlined and in **bold** text.

Project			Monitoring > Output Format		Output format						
Project Frame Rate	Imager Mode	SxS Rec Format	SDI 1/2	SDI 3/4	SDI 1	SDI 2	SDI 3	SDI 4			
59.94/50	4K 17:9	<u>XAVC-I 4K Class300/</u> Rec Off	4096x2160P 2SI	4096x2160P 2SI	4096x2160P YPbPr 3G Level B-DL						
			4096x2160P Square	4096x2160P Square	4096x2160P YPbPr 3G Level B-DL						
			2048x1080P	<u>1920x1080i</u>	2048x1080P YPbPr 3G Level B-DL	2048x1080P YPbPr 3G Level B-DL	1920x1080i YPbPr 1.5G	1920x1080i YPbPr 1.5G			
			1920x1080P	<u>1920x1080i</u>	1920x1080P YPbPr 3G Level B-DL	1920x1080P YPbPr 3G Level B-DL	1920x1080i YPbPr 1.5G	1920x1080i YPbPr 1.5G			
				<u>1920x1080i</u>	<u>1920x1080i</u>	1920x1080i YPbPr 1.5G	1920x1080i YPbPr 1.5G	1920x1080i YPbPr 1.5G	1920x1080i YPbPr 1.5G		
		3.8K 16:9	<u>XAVC-I QFHD</u> <u>Class300/</u> Rec Off	3840x2160P 2SI	3840x2160P 2SI	3840x2160P YPbPr 3G Level B-DL					
				3840x2160P Square	3840x2160P Square	3840x2160P YPbPr 3G Level B-DL					
				1920x1080P	<u>1920x1080i</u>	1920x1080P YPbPr 3G Level B-DL	1920x1080P YPbPr 3G Level B-DL	1920x1080i YPbPr 1.5G	1920x1080i YPbPr 1.5G		
					<u>1920x1080i</u>	1920x1080i YPbPr 1.5G	1920x1080i YPbPr 1.5G	1920x1080i YPbPr 1.5G	1920x1080i YPbPr 1.5G		
				4K 17:9/ 3.8K 16:9	MPEG 1920x1080i	1920x1080i	1920x1080i	1920x1080i YPbPr 1.5G	1920x1080i YPbPr 1.5G	1920x1080i YPbPr 1.5G	1920x1080i YPbPr 1.5G
29.97/25	4K 17:9	<u>XAVC-I 4K Class480/</u> <u>XAVC-I 4K Class300/</u> Rec Off	4096x2160P 2SI	–	4096x2160P YPbPr 3G Level B-DS		No output	No output			
			4096x2160P Square	4096x2160P Square	4096x2160P YPbPr 1.5G						
			2048x1080PsF	<u>1920x1080PsF</u>	2048x1080PsF YPbPr 1.5G	2048x1080PsF YPbPr 1.5G	1920x1080PsF YPbPr 1.5G	1920x1080PsF YPbPr 1.5G			
				<u>1920x1080PsF</u>	1920x1080PsF YPbPr 1.5G	1920x1080PsF YPbPr 1.5G	1920x1080PsF YPbPr 1.5G	1920x1080PsF YPbPr 1.5G			
		3.8K 16:9	<u>XAVC-I QFHD Class480/</u> <u>XAVC-I QFHD</u> <u>Class300/</u> Rec Off	3840x2160P 2SI	–	3840x2160P YPbPr 3G Level B-DS		No output	No output		
				3840x2160P Square	3840x2160P Square	3840x2160P YPbPr 1.5G					
					<u>1920x1080PsF</u>	1920x1080PsF YPbPr 1.5G	1920x1080PsF YPbPr 1.5G	1920x1080PsF YPbPr 1.5G	1920x1080PsF YPbPr 1.5G		
					<u>1920x1080PsF</u>	1920x1080PsF YPbPr 1.5G	1920x1080PsF YPbPr 1.5G	1920x1080PsF YPbPr 1.5G	1920x1080PsF YPbPr 1.5G		
				4K 17:9/ 3.8K 16:9	MPEG 1920x1080P	<u>1920x1080PsF</u>	<u>1920x1080PsF</u>	1920x1080PsF YPbPr 1.5G	1920x1080PsF YPbPr 1.5G	1920x1080PsF YPbPr 1.5G	1920x1080PsF YPbPr 1.5G
24	6K 3:2/4K 4:3/ 4K 17:9	<u>XAVC-I 4K Class480/</u> <u>XAVC-I 4K Class300/</u> Rec Off	4096x2160P 2SI	–	4096x2160P YPbPr 3G Level B-DS		No output	No output			
			4096x2160P Square	4096x2160P Square	4096x2160P YPbPr 1.5G						
			2048x1080P	<u>1920x1080P</u>	2048x1080PsF YPbPr 1.5G	2048x1080PsF YPbPr 1.5G	1920x1080P YPbPr 1.5G	1920x1080P YPbPr 1.5G			
				<u>1920x1080P</u>	1920x1080PsF YPbPr 1.5G	1920x1080PsF YPbPr 1.5G	1920x1080P YPbPr 1.5G	1920x1080P YPbPr 1.5G			

Project			Monitoring > Output Format		Output format			
Project Frame Rate	Imager Mode	SxS Rec Format	SDI 1/2	SDI 3/4	SDI 1	SDI 2	SDI 3	SDI 4
23.98	6K 3:2/ 4K 4:3/ 4K 17:9	XAVC-I 4K Class480/ XAVC-I 4K Class300/ Rec Off	4096x2160P 2SI	–	4096x2160P YPbPr 3G Level B-DS		No output	No output
			4096x2160P Square	4096x2160P Square	4096x2160P YPbPr 1.5G			
			2048x1080P	–	2048x1080PsF YPbPr 1.5G	2048x1080PsF YPbPr 1.5G	1920x1080P YPbPr 1.5G	1920x1080P YPbPr 1.5G
	3.8K 16:9	XAVC-I QFHD Class480/ XAVC-I QFHD Class300/ Rec Off	3840x2160P 2SI	–	3840x2160P YPbPr 3G Level B-DS		No output	No output
			3840x2160P Square	3840x2160P Square	4096x2160P YPbPr 1.5G			
			1920x1080P	1920x1080P	1920x1080PsF YPbPr 1.5G	1920x1080PsF YPbPr 1.5G	1920x1080P YPbPr 1.5G	1920x1080P YPbPr 1.5G
4K 4:3/ 4K 17:9/ 3.8K 16:9	MPEG 1920x1080P	1920x1080P	1920x1080P	1920x1080PsF YPbPr 1.5G	1920x1080PsF YPbPr 1.5G	1920x1080P YPbPr 1.5G	1920x1080P YPbPr 1.5G	

MONITOR OUT Connector/HDMI OUT Connector Output Formats

The digital signal from the MONITOR OUT and HDMI OUT connectors is output according to the Project category and Monitoring category settings in the menu. For details about Project category settings combinations, see “Recording Format Settings” (page 39).

Default values are shown underlined and in **bold** text.

Project		Monitoring > Output Format				Output format				
Project Frame Rate	Imager Mode	SxS Rec Format	SDI 1/2	SDI 3/4	Monitor	HDMI	Monitor Out	HDMI		
59.94/50	4K 17:9	<u>XAVC-I 4K Class300/</u> Rec Off	4096x2160P 2SI	4096x2160P 2SI	<u>1920x1080i</u>	4096x2160P <u>1920x1080i</u>	1920x1080i YPbPr 1.5G	4096x2160P		
			4096x2160P Square	4096x2160P Square	<u>1920x1080i</u>	<u>1920x1080i</u>		1920x1080i YPbPr 1.5G	1920x1080i	
			2048x1080P	<u>1920x1080i</u>	<u>1920x1080i</u>	<u>1920x1080i</u>	1920x1080i YPbPr 1.5G	1920x1080i		
			1920x1080P	<u>1920x1080i</u>	<u>1920x1080i</u>	<u>1920x1080i</u>	1920x1080i YPbPr 1.5G	1920x1080i		
			<u>1920x1080i</u>	<u>1920x1080i</u>	<u>1920x1080i</u>	<u>1920x1080i</u>	1920x1080i YPbPr 1.5G	1920x1080i		
			<u>1920x1080i</u>	<u>1920x1080i</u>	<u>1920x1080i</u>	<u>1920x1080i</u>	1920x1080i YPbPr 1.5G	1920x1080i		
	3.8K 16:9	<u>XAVC-I QFHD Class300/</u> Rec Off	3840x2160P 2SI	3840x2160P 2SI	1920x1080i	3840x2160P 1920x1080i	1920x1080i YPbPr 1.5G	3840x2160P		
			3840x2160P Square	3840x2160P Square	1920x1080i	1920x1080i		1920x1080i YPbPr 1.5G	1920x1080i	
			1920x1080P	<u>1920x1080i</u>	<u>1920x1080i</u>	<u>1920x1080i</u>	1920x1080i YPbPr 1.5G	1920x1080i		
			<u>1920x1080i</u>	<u>1920x1080i</u>	<u>1920x1080i</u>	<u>1920x1080i</u>	1920x1080i YPbPr 1.5G	1920x1080i		
			4K 17:9/ 3.8K 16:9	MPEG 1920x1080i	1920x1080i	1920x1080i	1920x1080i	1920x1080i 720x480P ¹⁾²⁾ 720x576P ¹⁾³⁾	1920x1080i YPbPr 1.5G	1920x1080i 720x480P 720x576P
			–	–	–	–	–	No output	No output	
29.97/25	4K 4:3/4K 17:9	<u>XAVC-I 4K Class480/</u> <u>XAVC-I 4K Class300/</u> Rec Off	4096x2160P 2SI	–	<u>1920x1080PsF</u>	4096x2160P <u>1920x1080PsF</u>	1920x1080PsF YPbPr 1.5G	4096x2160P		
			4096x2160P Square	4096x2160P Square	<u>1920x1080PsF</u>	<u>1920x1080PsF</u>		1920x1080PsF YPbPr 1.5G	1920x1080PsF	
			2048x1080PsF	<u>1920x1080PsF</u>	<u>1920x1080PsF</u>	<u>1920x1080PsF</u>	1920x1080PsF YPbPr 1.5G	1920x1080PsF		
			<u>1920x1080PsF</u>	<u>1920x1080PsF</u>	<u>1920x1080PsF</u>	<u>1920x1080PsF</u>	1920x1080PsF YPbPr 1.5G	1920x1080PsF		
			3.8K 16:9	<u>XAVC-I QFHD Class480/</u> <u>XAVC-I QFHD Class300/</u> Rec Off	3840x2160P 2SI	–	<u>1920x1080PsF</u>	3840x2160P <u>1920x1080PsF</u>	1920x1080PsF YPbPr 1.5G	3840x2160P
			3840x2160P Square		3840x2160P Square	<u>1920x1080PsF</u>	<u>1920x1080PsF</u>	1920x1080PsF YPbPr 1.5G		1920x1080PsF
	<u>1920x1080PsF</u>	<u>1920x1080PsF</u>	<u>1920x1080PsF</u>		<u>1920x1080PsF</u>	1920x1080PsF YPbPr 1.5G	1920x1080PsF			
	4K 17:9/ 3.8K 16:9	MPEG 1920x1080P	<u>1920x1080PsF</u>	<u>1920x1080PsF</u>	<u>1920x1080PsF</u>	<u>1920x1080PsF</u>	1920x1080PsF YPbPr 1.5G	1920x1080PsF		
	24	6K 3:2/ 4K 4:3/ 4K 17:9	<u>XAVC-I 4K Class480/</u> <u>XAVC-I 4K Class300/</u> Rec Off	4096x2160P 2SI	–	<u>1920x1080P</u>	4096x2160P <u>1920x1080P</u>	1920x1080P YPbPr 1.5G	4096x2160P	
				4096x2160P Square	4096x2160P Square	<u>1920x1080P</u>	<u>1920x1080P</u>		1920x1080P YPbPr 1.5G	1920x1080P
				2048x1080P	<u>1920x1080P</u>	<u>1920x1080P</u>	<u>1920x1080P</u>	1920x1080P YPbPr 1.5G	1920x1080P	
				<u>1920x1080P</u>	<u>1920x1080P</u>	<u>1920x1080P</u>	<u>1920x1080P</u>	1920x1080P YPbPr 1.5G	1920x1080P	
<u>1920x1080P</u>				<u>1920x1080P</u>	<u>1920x1080P</u>	<u>1920x1080P</u>	1920x1080P YPbPr 1.5G	1920x1080P		

Project			Monitoring > Output Format				Output format	
Project Frame Rate	Imager Mode	SxS Rec Format	SDI 1/2	SDI 3/4	Monitor	HDMI	Monitor Out	HDMI
23.98	6K 3:2/ 4K 4:3/ 4K 17:9	XAVC-I 4K Class480/ XAVC-I 4K Class300/ Rec Off	4096×2160P 2SI	–	1920×1080P	4096×2160P 1920×1080P	1920×1080P YPbPr 1.5G	4096×2160P
			4096×2160P Square	4096×2160P Square	1920×1080P	1920×1080P		1920×1080P YPbPr 1.5G
			2048×1080P	1920×1080P	1920×1080P	1920×1080P	1920×1080P YPbPr 1.5G	1920×1080P
			1920×1080P	1920×1080P	1920×1080P	1920×1080P	1920×1080P YPbPr 1.5G	1920×1080P
	3.8K 16:9	XAVC-I QFHD Class480/ XAVC-I QFHD Class300/ Rec Off	3840×2160P 2SI	–	1920×1080P	3840×2160P 1920×1080P	1920×1080P YPbPr 1.5G	3840×2160P
			3840×2160P Square	3840×2160P Square	1920×1080P	1920×1080P		1920×1080P YPbPr 1.5G
			1920×1080P	1920×1080P	1920×1080P	1920×1080P	1920×1080P YPbPr 1.5G	1920×1080P
			1920×1080P	1920×1080P	1920×1080P	1920×1080P	1920×1080P YPbPr 1.5G	1920×1080P
	4K 4:3/ 4K 17:9/ 3.8K 16:9	MPEG 1920×1080P	1920×1080P	1920×1080P	1920×1080P	1920×1080P	1920×1080P YPbPr 1.5G	1920×1080P

¹⁾ When AXS Rec Format is set to Rec Off, this output is selected when Technical > System Configuration > SD HDMI is set to On in the menu

²⁾ When Project Frame Rate is 59.94.

³⁾ When Project Frame Rate is 50.0.

Error/Warning Indications

If a warning, caution, or operating condition that requires confirmation occurs on the unit, a message is displayed on the sub display, the REC lamp starts flashing, and a warning sound is emitted.

The buzzer is output to the built-in speaker or to the headphones connected via the headphone connector.

When the unit is turned on, a message appears on the sub display screen prompting you to execute APR if the auto adjustment for the image sensor (APR) has not been performed for a certain period of time. In this case, follow the on-screen instructions to execute APR (page 49).

Error Display

The unit will stop operation when the following kind of display occurs.

Error display indication	Buzzer	REC lamp	Cause and Solution
E + Error code	Intermittent	High-speed flashing	The unit may be defective. Recording stops even if ●REC is displayed on the viewfinder screen. Turn off the power and check the connected equipment, cables, and media. If the error persists when the unit is turned on again, contact your Sony service representative. (If power cannot be turned off by setting the power switch to OFF, remove the battery pack or the DC IN source.)

Warning Display

When one of the following messages occurs, use the following table to resolve the problem.

Warning display indication	Buzzer	REC lamp	Cause and Solution
Media Full ¹⁾	Continuous	High-speed flashing	Clips could not be recorded, copied, or split because there is no remaining capacity on the SxS memory card. Replace immediately.
Battery End ¹⁾	Continuous	High-speed flashing	The battery pack is dead. Recording is disabled. Stop operation and recharge the battery pack.
Temperature High ¹⁾	Intermittent	Flashing	The internal temperature is high. Turn off the unit and allow it to cool down before operating it again.

Warning display indication	Buzzer	REC lamp	Cause and Solution
Insufficient Voltage ¹⁾	Continuous	High-speed flashing	The DC IN voltage is too low. Recording is disabled. Connect another power source.
EXT. I/F Signal Error	–	–	An error was detected with the signal on the mounting terminal for an expansion unit. Check the connection to the AXS-R7 or other device.
AXS Recorder Temp. High ¹⁾	–	–	The internal temperature of the AXS recorder is high. Turn off the unit and allow it to cool down before operating it again.

¹⁾ Message is not displayed on the monitor screen.

Caution and Operation Confirmation Display

The following caution and operation confirmation messages may appear on the monitor screen or sub display, and warning icons may be displayed and messages displayed in the Info category > Camera Condition in the menu. Follow the instructions provided to resolve the issue.

Display indication	Cause and Solution
Battery Error Please Change Battery	An error was detected in the battery pack. Replace with a normal battery pack.
Backup Battery End Please Change	The remaining capacity of the backup battery is insufficient. Replace the backup battery.
Cannot Use SxS(A)* Please Change	A memory card that has been partitioned or a memory card containing more clips that can be handled by the unit was inserted. The card cannot be used in the unit, and must be replaced.
Cannot Use SxS(A)* Unsupported File System	A card using a different file system or an unformatted card was inserted. The card cannot be used in the unit, and must be replaced or formatted using the unit.
Media Error SxS(A)* Needs to be Restored	An error occurred with the memory card. The card requires restoration. Restore the card.
SxS(A)* Error Recording Halted Playback Halted	Recording or playback stopped because an error occurred on the memory card. If the problem persists, replace the memory card.

Display indication	Cause and Solution
Input AES/EBU is Invalid Emphasis	Emphasis signal that is not compatible with the AES/EBU input was input. The unit is compatible with 50u-15u Emphasis only.
Input AES/EBU is not Pro Use	A signal other than Professional Use was input to the AES/EBU input. The unit is compatible with Professional Use only.
Fan Stopped	The fan in the unit has stopped. Avoid use under high temperature conditions. Turn the unit off and contact a Sony service representative.
AXS Recorder Fan Stopped	The fan in the AXS-R7 that is connected to the unit has stopped. Avoid use under high temperature conditions. Remove the AXS-R7 from the unit and contact a Sony service representative.
Unsupported FPS Change AXS(A) to AXS S48 Memory	Unsupported AXS memory was detected. Recording cannot be performed. Change the recording format for the AXS memory card, or change the card to an AXS-A512S48 or AXS-A1TS48.
Abnormal Lens Communication Please Check "Lens IF" Setting	The type of the connected lens does not match the unit's setting. Check the Technical > System Configuration > Lens Interface setting in the menu.
Please Execute APR	The auto adjusting of the image sensor (APR) has not been executed for a certain period. Execute APR by pressing the MENU dial.
Invalid setting value was reset: Media/Clip Naming/Camera Position Please save All File again	The setting of Clip Naming was reset because an invalid All-settings file is loaded. Save the All-settings file again after setting the desired values.
XXXX License Y days Remaining (XXXX: Type of license, Y: Number of days remaining)	There are 2 days remaining before the license for the software option will expire.

* "SxS(B)" is displayed for the SxS memory card in slot B, "AXS(A)" is displayed for the AXS memory card in slot A of the AXS-R7, and "AXS(B)" is displayed for the AXS memory card in slot B of the AXS-R7.

Items Saved in Files

Table legend

Yes: Saved

No: Not saved

–: Not saved (temporary setting)

Shooting Menu

Item	Sub-item	File type
All		
Shutter ¹⁾	Shutter Select	Yes
	Step/Cont. Select	Yes
	Add/Change Step	Yes
	Delete Step	Yes
ND	ND Position	Yes
Exposure Index	EI Select	Yes
White Balance ¹⁾	Color Temp. Select	Yes
	Add/Change Step	Yes
	Delete Step	Yes
LUT Select	SDI 1/2	Yes
	SDI 3/4	Yes
	Monitor	Yes
	HDMI	Yes
	VF LUT	Yes
	SxS Rec	Yes
	Sub Rec	Yes
Look	Category	–
	Preset Look Select	Yes

¹⁾ Selection options added or edited by a user are also saved.

Project Menu

Item	Sub-item	File type	
All			
Basic Setting	Imager Mode	Yes	
	Project Frame Rate	Yes	
	AXS Rec Format	Yes	
	SxS Rec Format	Yes	
	Sub Rec Format	Yes	
	SxS/Output De-Squeeze	No	
Assignable Button	<1>	Yes	
	<2>	Yes	
	<3>	Yes	
	<4>	Yes	
	<User 1>	Yes	
	<User 2>	Yes	
	<User 3>	Yes	
	<User 4>	Yes	
	<User 5>	Yes	
	All File	Load SD Card	–
		Save SD Card	–
File ID		Yes	
Format SD Card		–	

TC/Media Menu

Item	Sub-item	File type
		All
Timecode	Mode	Yes
	Manual Setting	–
	Reset	–
	TC Format	Yes
	TC Source	–
	Time Data Display	Yes
Clip Name Format	Camera ID	Yes
	Reel Number	Yes
	Camera Position	Yes
Format Media	AXS Slot A	–
	AXS Slot B	–
	SxS Slot A	–
	SxS Slot B	–
	SD Card	–
Update Media	AXS Slot A	–
	AXS Slot B	–
	SxS Slot A	–
	SxS Slot B	–

Monitoring Menu

Item	Sub-item	File type	
		All	
Output Format	SDI 1/2	Yes	
	SDI 3/4	Yes	
	Monitor	Yes	
	HDMI	Yes	
VF OSD	Status Info	Yes	
	Status Info Select	Yes	
	Frame Line	Yes	
	Frame Line Select	Yes	
SDI OSD	Status Info	Yes	
	Status Info Select	Yes	
	Frame Line	Yes	
	Frame Line Select	Yes	
Monitor OSD	Status Info	Yes	
	Status Info Select	Yes	
	Frame Line	Yes	
	Frame Line Select	Yes	
HDMI OSD	OSD Status	–	
	Status Info A	Project	Yes
Status Info A	Timecode	Yes	
	Audio Level Meter	Yes	
	Look Status	Yes	
	Output LUT	Yes	
	Recording LUT	Yes	
	VF Status	Yes	
	Lens Status	Yes	
	Status Info B	Project	Yes
	Timecode	Yes	
	Audio Level Meter	Yes	
Look Status	Yes		
Output LUT	Yes		
Recording LUT	Yes		
VF Status	Yes		
Lens Status	Yes		
Display Info	Focus Distance Format	Yes	

Item	Sub-item	File type
		All
Frame Line A	Center Marker	Yes
	Aspect Ratio	Yes
	Aspect Safety Zone	Yes
	Picture Area	Yes
	Safety Zone	Yes
	User Frame Line	Yes
Frame Line B	Center Marker	Yes
	Aspect Ratio	Yes
	Aspect Safety Zone	Yes
	Picture Area	Yes
	Safety Zone	Yes
	User Frame Line	Yes
Frame Line	Color	Yes
	Center Marker	Yes
	Safety Area	Yes
	Aspect Ratio Type	Yes
	Aspect Ratio Select	Yes
	Aspect Ratio Mask	Yes
	Aspect Safety Area	Yes
	Frame Line on Playback	Yes
User Frame Line	Width	Yes
	Height	Yes
	H Position	Yes
	V Position	Yes
VF Display	VF LUT	Yes
	Status Info	Yes
	Status Info Select	Yes
	Frame Line	Yes
	Frame Line Select	Yes
	Color	Yes
VF Function	Double Speed Scan	Yes
	Peaking Frequency	Yes
	Zebra	Yes
	Zebra Select	Yes
	Zebra1 Level	Yes
	Zebra1 Aperture Level	Yes
	Zebra2 Level	Yes

Audio Menu

Item	Sub-item	File type
		All
Audio Input	CH-1 Audio Select	Yes
	CH-2 Audio Select	Yes
	CH-1 Audio Level	Yes
	CH-2 Audio Level	Yes
	MIC Reference	Yes
Audio Monitor	Monitor CH	Yes
	Monitor Level	Yes
Audio Configuration	Input Limiter Mode	Yes
	AGC Level	Yes
	AGC Mono/Stereo	Yes
	MIC Input Mono/Stereo	Yes
	Phantom Power +48V	Yes
	Monitor Output CH Pair	Yes
	Headphone Mono/ST	Yes

Technical Menu

Item	Sub-item	File type
		All
Test Signals	Color Bars	Yes
	Color Bars Type	Yes
	1kHz Tone on Color Bars	Yes
	Test Saw	Yes
Switch & Rec Light	Lock Operator Side	Yes
	Lock Assistant Side	Yes
	Rec Light	Yes
	Rec Start/Stop Beep	Yes
System Configuration	Fan Control	Yes
	Lens Interface	Yes
	SDI Rec Remote Trigger	Yes
	SD HDMI	Yes
	Shutter Mode	Yes
APR	APR	–
	Reset	–
Battery	Near End:Info Battery	Yes
	End:Info Battery	Yes
	Near End:Sony Battery	Yes
	End:Sony Battery	Yes
	Near End:Other Battery	Yes
	End:Other Battery	Yes
	Detected Battery	–
DC Voltage Alarm	DC Low Voltage1	Yes
	DC Low Voltage2	Yes
	DC(24V) Low Voltage1	Yes
	DC(24V) Low Voltage2	Yes
Control Display	Brightness level	Yes
Genlock	Input Source	Yes
	Reference Lock Type	–

Maintenance Menu

Item	Sub-item	File type
		All
Clock Set	Time Zone	Yes
	Date Mode	Yes
	Date	–
	Time	–
Language	Select	Yes
Hours Meter	Camera(System)	–
	R7 Recorder(System)	–
	Camera(Resettable)	–
	R7 Recorder(Resettable)	–
	Reset-Cam(Resettable)	–
Reset to Default	Reset-R7(Resettable)	–
	Reset	–
License Options	Install: xxx	–
	Anamorphic	–
	Full Frame	–
	Unique Device ID	–
Firmware	Camera	–
	AXS	–
	FW Update-camera	–

Licenses

MPEG-4 Visual Patent Portfolio License

THIS PRODUCT IS LICENSED UNDER THE MPEG-4 VISUAL PATENT PORTFOLIO LICENSE FOR THE PERSONAL AND NON-COMMERCIAL USE OF A CONSUMER FOR

(i) ENCODING VIDEO IN COMPLIANCE WITH THE MPEG-4 VISUAL STANDARD ("MPEG-4 VIDEO") AND/OR

(ii) DECODING MPEG-4 VIDEO THAT WAS ENCODED BY A CONSUMER ENGAGED IN A PERSONAL AND NON-COMMERCIAL ACTIVITY AND/OR WAS OBTAINED FROM A VIDEO PROVIDER LICENSED BY MPEG LA TO PROVIDE MPEG-4 VIDEO.

NO LICENSE IS GRANTED OR SHALL BE IMPLIED FOR ANY OTHER USE. ADDITIONAL INFORMATION INCLUDING THAT RELATING TO PROMOTIONAL, INTERNAL AND COMMERCIAL USES AND LICENSING MAY BE OBTAINED FROM MPEG LA, LLC. SEE [HTTP://WWW.MPEGLA.COM](http://www.mpegla.com)

MPEG LA is offering licenses for (i) manufacturing/sales of any storage media storing MPEG-4 Visual video information (ii) distribution/broadcasting of MPEG-4 Visual video information in any manner (such as online video distribution service, internet broadcasting, TV broadcasting).

Other usage of this product may be required to obtain license from MPEG LA. Please contact MPEG LA for any further information. MPEG LA, L.L.C., 250 STEELE STREET, SUITE 300, DENVER, COLORADO 80206
<http://www.mpegla.com>

MPEG-4 AVC Patent Portfolio License

THIS PRODUCT IS LICENSED UNDER THE AVC PATENT PORTFOLIO LICENSE FOR THE PERSONAL USE OF A CONSUMER OR OTHER USES IN WHICH IT DOES NOT RECEIVE REMUNERATION TO

(i) ENCODE VIDEO IN COMPLIANCE WITH THE AVC STANDARD ("AVC VIDEO") AND/OR

(ii) DECODE AVC VIDEO THAT WAS ENCODED BY A CONSUMER ENGAGED IN A PERSONAL ACTIVITY AND/OR WAS OBTAINED FROM A VIDEO PROVIDER LICENSED TO PROVIDE AVC VIDEO.

NO LICENSE IS GRANTED OR SHALL BE IMPLIED FOR ANY OTHER USE. ADDITIONAL INFORMATION MAY BE OBTAINED FROM MPEG LA, L.L.C. SEE [HTTP://WWW.MPEGLA.COM](http://www.mpegla.com)

On Accessing Software to which the GPL/LGPL Applies

This product uses software to which the GPL/LGPL applies. This informs you that you have a right to have access to, modify, and redistribute source code for these software programs under the conditions of the GPL/LGPL.

The source code is provided on the internet. Use the following URL and follow the download instructions.
<http://www.sony.net/Products/Linux/common/search.html>

We would prefer that you do not contact us about the contents of the source code.

For the content of these licenses, see "License1.pdf" in the "License" folder of the supplied CD-ROM.

Adobe Reader must be installed on your computer to view PDF files.

If Adobe Reader is not installed on your computer, you can download it by accessing the following URL.

<http://get.adobe.com/reader/>

Open Software Licenses

On the basis of license contracts between Sony and the software copyright holders, this product uses open software.

To meet the requirements of the software copyright holders, Sony is obligated to inform you of the content of these licenses.

For the content of these licenses, see "License1.pdf" in the "License" folder of the supplied CD-ROM.

Specifications

General Specifications

Mass	Approx. 3.9 kg (8 lb 9.6 oz) (excluding handle, VF attachment, bottom cover)
Dimensions	See page 77.
Power requirements	12 V DC (11 V to 17 V) 24 V DC (22 V to 32 V)
Power consumption	Approx. 60 W (when recording XAVC)
Operating temperature	0 °C to 40 °C (32 °F to 104 °F)
Storage temperature	-20 °C to +60 °C (-4 °F to +140 °F)
Continuous operating time	Approx. 60 minutes (using BP-FLX75)
Recording format (video)	RAW SQ (4K, 17:9) (when the AXS-R7 is attached) X-OCN ST (6K 3:2, 4K 4:3, 4K 17:9) (when the AXS-R7 is attached) X-OCN LT (6K 3:2, 4K 4:3, 4K 17:9) (when the AXS-R7 is attached) XAVC-I Class480 (4K, QFHD) XAVC-I Class300 (4K, QFHD) MPEG HD422 (HD)
Recording format (audio)	LPCM 8CH (2CH recording/playback), 24-bit, 48 kHz
Recording frame rate	RAW SQ (when the AXS-R7 is attached): 4K 17:9/3.8K 16:9 59.94P/50P/29.97P/25P/24P/ 23.98P X-OCN (when the AXS-R7 is attached): 6K 3:2 24P/23.98P 4K 4:3 24P/23.98P 4K 17:9/3.8K 16:9 59.94P/50P/29.97P/25P/24P/ 23.98P

XAVC-I Class480:	4K: 4096×2160 29.97P/25P/24P/23.98P QFHD: 3840×2160 29.97P/25P/ 23.98P
XAVC-I Class300:	4K: 4096×2160 59.94P/50P/29.97P/25P/24P/ 23.98P QFHD: 3840×2160 59.94P/50P/29.97P/25P/23.98P
MPEG HD422(50Mbps):	HD: 1920×1080 29.97P/25P/23.98P/59.94i/50i
Recording/playback time	XAVC-I Class480 23.98P Approx. 34 minutes when using SBP-128B/C/D XAVC-I Class300 23.98P Approx. 54 minutes when using SBP-128B/C/D MPEG2 HD422 Approx. 108 minutes when using SBS-64G1A/B

[Note]

The recording and playback times are for a continuous recording as a single clip. The actual times may be shorter, depending on the number of clips recorded. The recording/playback time may vary due to usage conditions and memory characteristics.

Camera

Imaging device	35 mm full size, single-chip CMOS image sensor
Number of pixels	24.8 M (total)
Built-in filters	

		ND filter A		
		Clear	0.3 (1/2)	0.6 (1/4)
ND filter B	Clear	Clear	0.3 (1/2)	0.6 (1/4)
	0.9 (1/8)	0.9 (1/8)	1.2 (1/16)	1.5 (1/32)
	1.8 (1/64)	1.8 (1/64)	2.1 (1/128)	2.4 (1/256)

ISO sensitivity	ISO 500 (D55 light source)
Lens mount	PL mount (with lens mount adaptor)
Flange focal length	52 mm
Latitude	15+ stops

Input/Output

Audio input	CH-1/CH-2: XLR-type 5-pin (female) (1), LINE / AES/EBU / MIC / MIC+48V selectable
DC input	XLR-type 4-pin (male), 11 V to 17 V or 22 V to 32 V DC
DC output (12 V)	Hirose 4-pin (1), 11 V to 17 V DC (Output voltage: Same as input voltage, Maximum output current: 1.0 A), 22 V to 32 V DC (Output voltage: 15 V, Maximum output current: 0.8 A), Using battery adaptor

[Notes]

- You can output a REC Tally signal and input a REC Trigger signal through the 12V OUT connector.
- Connect to the 12V OUT connector only devices with current consumption of 1.0 A or lower when the input voltage is 11 V to 17 V, or 0.8 A or lower when the input voltage is 22 V to 32 V.

DC output (24 V)	Fischer 3-pin (2), 11 V to 17 V DC (Output voltage: 24 V, Maximum output current: 1.0 A), 22 V to 32 V DC (Output voltage: Same as input voltage, Maximum output current: 2.0 A)
------------------	--

[Note]

Connect to the 24V OUT connector only devices with current consumption of 1.0 A or lower when the input voltage is 11 V to 17 V, or 2.0 A or lower when the input voltage is 22 V to 32 V.

SDI output	BNC type (4) 3G-SDI: SMPTE ST424/425 Level B-DL/DS HD SDI: SMPTE ST292 compliant
AUX	LEMO 5-pin (1)

Viewfinder output	LEMO 26-pin (1)
Network	RJ45 type (1)
Remote control	8-pin (1)
MONITOR output	BNC type (1) HD SDI: SMPTE ST292 compliant
Timecode input	TC IN: BNC type (1)
GENLOCK input	BNC type (1)
HDMI output	Type A (1)
External device connector	USB host: Type A (1)
Headphones output	Stereo mini jack (1)
Speaker output	Monaural

Media Slots

Type	ExpressCard/34 slot (2) SD card slot (1)
------	---

Supplied Accessories

VF attachment (1)
Handle (1)
VF cable (1)
Shim (circular) (1)
Shim (1/3 arc) (15)
Lens mount cover (1)
Before Using this Unit (1)
Operating Instructions (CD-ROM) (1)

Optional Accessories

0.7-inch type viewfinder	DVF-EL200
7-inch type viewfinder	DVF-L700
VF cable for attaching DVF-L700	A-2201-632-A or A-2201-633-A
Portable Memory Recorder	AXS-R7
SxS memory cards (SxS-1/SxS Pro/SxS Pro+)	SBP-256D, SBP-128B/C/D, SBP-64A/B/C/D, SBP-32G1A/B
Card Reader	SBAC-US30, SBAC-UT100, AXS-AR1
Shoulder Adaptor (attaches to VCT-14 using V shoe)	VCT-FSAS
PL mount lens	SCL-PK6/F (Feet), SCL-PK6/M (Meters) (6-lens kit: 20, 25, 35, 50, 85, 135 mm), SCL-P11X15 (11 mm to 16 mm zoom)
Battery Pack	BP-FL75, BP-FLX75
AC Adaptor	AC-DN2B, AC-DN10
Microphone	ECM-680S, ECM-678*, ECM-674* (*: EC-0.5X3F5M 3-pin XLR to 5-pin XLR adaptor cable required)
Dual Battery Adaptor	BKW-L200 (connection via battery connection adaptor)
SDI/HDMI Monitor	BVM series, PVM series, LMD series
XQD memory cards (QDA-EX1 XQD to SxS ExpressCard Adaptor required)	QD-S64E, QD-S32E, QD-N64, QD-G128A, QD-G64A, QD-G32A

Design and specifications are subject to change without notice.

Notes

- Always make a test recording, and verify that it was recorded successfully. SONY WILL NOT BE LIABLE FOR DAMAGES OF ANY KIND INCLUDING, BUT NOT LIMITED TO, COMPENSATION OR REIMBURSEMENT ON ACCOUNT OF FAILURE OF THIS UNIT OR ITS RECORDING MEDIA, EXTERNAL STORAGE SYSTEMS OR ANY OTHER MEDIA OR STORAGE SYSTEMS TO RECORD CONTENT OF ANY TYPE.
- Always verify that the unit is operating properly before use. SONY WILL NOT BE LIABLE FOR DAMAGES OF ANY KIND INCLUDING, BUT NOT LIMITED TO, COMPENSATION OR REIMBURSEMENT ON ACCOUNT OF THE LOSS OF PRESENT OR PROSPECTIVE PROFITS DUE TO FAILURE OF THIS UNIT, EITHER DURING THE WARRANTY PERIOD OR AFTER EXPIRATION OF THE WARRANTY, OR FOR ANY OTHER REASON WHATSOEVER.
- SONY WILL NOT BE LIABLE FOR CLAIMS OF ANY KIND MADE BY USERS OF THIS UNIT OR MADE BY THIRD PARTIES.
- SONY WILL NOT BE LIABLE FOR THE LOSS, REPAIR, OR REPRODUCTION OF ANY DATA RECORDED ON THE INTERNAL STORAGE SYSTEM, RECORDING MEDIA, EXTERNAL STORAGE SYSTEMS OR ANY OTHER MEDIA OR STORAGE SYSTEMS.
- SONY WILL NOT BE LIABLE FOR THE TERMINATION OR DISCONTINUATION OF ANY SERVICES RELATED TO THIS UNIT THAT MAY RESULT DUE TO CIRCUMSTANCES OF ANY KIND.

Dimensions

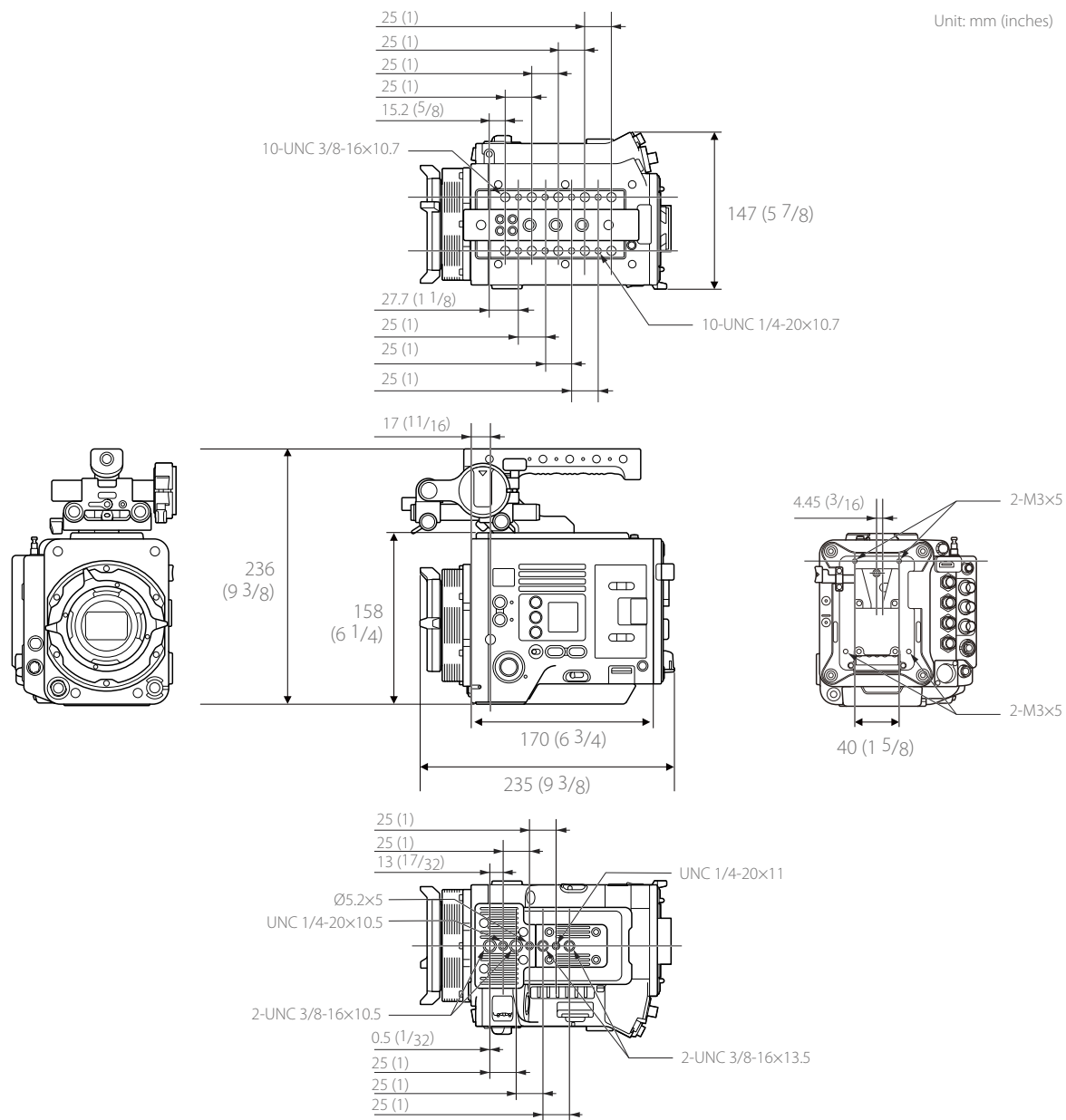

Trademarks

- XAVC and **XAVC** are registered trademarks of Sony Corporation.
- The terms HDMI and HDMI High-Definition Multimedia Interface, and the HDMI Logo are trademarks or registered trademarks of HDMI Licensing LLC in the United States and other countries.
- All system names and product names are registered trademarks or trademarks of their respective owners. Trademarked items are not indicated by ® or ™ symbols in this document.