



Aid NEXIS[®]

Setup and Maintenance Guide

Aid NEXIS Version 2021.3

Legal Notices

Product specifications are subject to change without notice and do not represent a commitment on the part of Avid Technology, Inc.

This product is subject to the terms and conditions of a software license agreement provided with the software. The product may only be used in accordance with the license agreement.

This product may be protected by one or more U.S. and non-U.S patents. Details are available at www.avid.com/patents.

Part of the software embedded in this product is gSOAP software.

Portions created by gSOAP are Copyright (C) 2001-2004 Robert A. van Engelen, Genivia inc. All Rights Reserved.

THE SOFTWARE IN THIS PRODUCT WAS IN PART PROVIDED BY GENIVIA INC AND ANY EXPRESS OR IMPLIED WARRANTIES, INCLUDING, BUT NOT LIMITED TO, THE IMPLIED WARRANTIES OF MERCHANTABILITY AND FITNESS FOR A PARTICULAR PURPOSE ARE DISCLAIMED. IN NO EVENT SHALL THE AUTHOR BE LIABLE FOR ANY DIRECT, INDIRECT, INCIDENTAL, SPECIAL, EXEMPLARY, OR CONSEQUENTIAL DAMAGES (INCLUDING, BUT NOT LIMITED TO, PROCUREMENT OF SUBSTITUTE GOODS OR SERVICES; LOSS OF USE, DATA, OR PROFITS; OR BUSINESS INTERRUPTION) HOWEVER CAUSED AND ON ANY THEORY OF LIABILITY, WHETHER IN CONTRACT, STRICT LIABILITY, OR TORT (INCLUDING NEGLIGENCE OR OTHERWISE) ARISING IN ANY WAY OUT OF THE USE OF THIS SOFTWARE, EVEN IF ADVISED OF THE POSSIBILITY OF SUCH DAMAGE.

This guide is protected by copyright. This guide is for your personal use and may not be reproduced or distributed, in whole or in part, without permission of Avid. Reasonable care has been taken in preparing this guide; however, it may contain omissions, technical inaccuracies, or typographical errors. Avid Technology, Inc. disclaims liability for all losses incurred through the use of this document. Product specifications are subject to change without notice.

Copyright © 2021 Avid Technology, Inc. and its licensors. All rights reserved.

The following disclaimer is required by Apple Computer, Inc.:

APPLE COMPUTER, INC. MAKES NO WARRANTIES WHATSOEVER, EITHER EXPRESS OR IMPLIED, REGARDING THIS PRODUCT, INCLUDING WARRANTIES WITH RESPECT TO ITS MERCHANTABILITY OR ITS FITNESS FOR ANY PARTICULAR PURPOSE. THE EXCLUSION OF IMPLIED WARRANTIES IS NOT PERMITTED BY SOME STATES. THE ABOVE EXCLUSION MAY NOT APPLY TO YOU. THIS WARRANTY PROVIDES YOU WITH SPECIFIC LEGAL RIGHTS. THERE MAY BE OTHER RIGHTS THAT YOU MAY HAVE WHICH VARY FROM STATE TO STATE.

The following disclaimer is required by Sam Leffler and Silicon Graphics, Inc. for the use of their TIFF library:

Copyright © 1988-1997 Sam Leffler
Copyright © 1991-1997 Silicon Graphics, Inc.

Permission to use, copy, modify, distribute, and sell this software [i.e., the TIFF library] and its documentation for any purpose is hereby granted without fee, provided that (i) the above copyright notices and this permission notice appear in all copies of the software and related documentation, and (ii) the names of Sam Leffler and Silicon Graphics may not be used in any advertising or publicity relating to the software without the specific, prior written permission of Sam Leffler and Silicon Graphics.

THE SOFTWARE IS PROVIDED "AS-IS" AND WITHOUT WARRANTY OF ANY KIND, EXPRESS, IMPLIED OR OTHERWISE, INCLUDING WITHOUT LIMITATION, ANY WARRANTY OF MERCHANTABILITY OR FITNESS FOR A PARTICULAR PURPOSE.

IN NO EVENT SHALL SAM LEFFLER OR SILICON GRAPHICS BE LIABLE FOR ANY SPECIAL, INCIDENTAL, INDIRECT OR CONSEQUENTIAL DAMAGES OF ANY KIND, OR ANY DAMAGES WHATSOEVER RESULTING FROM LOSS OF USE, DATA OR PROFITS, WHETHER OR NOT ADVISED OF THE POSSIBILITY OF DAMAGE, AND ON ANY THEORY OF LIABILITY, ARISING OUT OF OR IN CONNECTION WITH THE USE OR PERFORMANCE OF THIS SOFTWARE.

The following disclaimer is required by the Independent JPEG Group:

This software is based in part on the work of the Independent JPEG Group.

This Software may contain components licensed under the following conditions:

Copyright (c) 1989 The Regents of the University of California. All rights reserved.

Redistribution and use in source and binary forms are permitted provided that the above copyright notice and this paragraph are duplicated in all such forms and that any documentation, advertising materials, and other materials related to such distribution and use acknowledge that the software was developed by the University of California, Berkeley. The name of the University may not be used to endorse or promote products derived from this software without specific prior written permission. THIS SOFTWARE IS PROVIDED "AS IS" AND WITHOUT ANY EXPRESS OR IMPLIED WARRANTIES, INCLUDING, WITHOUT LIMITATION, THE IMPLIED WARRANTIES OF MERCHANTABILITY AND FITNESS FOR A PARTICULAR PURPOSE.

Copyright (C) 1989, 1991 by Jef Poskanzer.

Permission to use, copy, modify, and distribute this software and its documentation for any purpose and without fee is hereby granted, provided that the above copyright notice appear in all copies and that both that copyright notice and this permission notice appear in supporting documentation. This software is provided "as is" without express or implied warranty.

Copyright 1995, Trinity College Computing Center. Written by David Chappell.

Permission to use, copy, modify, and distribute this software and its documentation for any purpose and without fee is hereby granted, provided that the above copyright notice appear in all copies and that both that copyright notice and this permission notice appear in supporting documentation. This software is provided "as is" without express or implied warranty.

Copyright 1996 Daniel Dardailler.

Permission to use, copy, modify, distribute, and sell this software for any purpose is hereby granted without fee, provided that the above copyright notice appear in all copies and that both that copyright notice and this permission notice appear in supporting documentation, and that the name of Daniel Dardailler not be used in advertising or publicity pertaining to distribution of the software without specific, written prior permission. Daniel Dardailler makes no representations about the suitability of this software for any purpose. It is provided "as is" without express or implied warranty.

Modifications Copyright 1999 Matt Koss, under the same license as above.

Copyright (c) 1991 by AT&T.

Permission to use, copy, modify, and distribute this software for any purpose without fee is hereby granted, provided that this entire notice is included in all copies of any software which is or includes a copy or modification of this software and in all copies of the supporting documentation for such software.

THIS SOFTWARE IS BEING PROVIDED "AS IS", WITHOUT ANY EXPRESS OR IMPLIED WARRANTY. IN PARTICULAR, NEITHER THE AUTHOR NOR AT&T MAKES ANY REPRESENTATION OR WARRANTY OF ANY KIND CONCERNING THE MERCHANTABILITY OF THIS SOFTWARE OR ITS FITNESS FOR ANY PARTICULAR PURPOSE.

This product includes software developed by the University of California, Berkeley and its contributors.

The following disclaimer is required by Paradigm Matrix:

Portions of this software licensed from Paradigm Matrix.

The following disclaimer is required by Ray Sauers Associates, Inc.:

"Install-It" is licensed from Ray Sauers Associates, Inc. End-User is prohibited from taking any action to derive a source code equivalent of "Install-It," including by reverse assembly or reverse compilation, Ray Sauers Associates, Inc. shall in no event be liable for any damages resulting from reseller's failure to perform reseller's obligation; or any damages arising from use or operation of reseller's products or the software; or any other damages, including but not limited to, incidental, direct, indirect, special or consequential Damages including lost profits, or damages resulting from loss of use or inability to use reseller's products or the software for any reason including copyright or patent infringement, or lost data, even if Ray Sauers Associates has been advised, knew or should have known of the possibility of such damages.

The following disclaimer is required by Altura Software, Inc. for the use of its Mac2Win software and Sample Source Code:

©1993–1998 Altura Software, Inc.

The following disclaimer is required by Interplay Entertainment Corp.:

The "Interplay" name is used with the permission of Interplay Entertainment Corp., which bears no responsibility for Avid products.

This product includes portions of the Alloy Look & Feel software from Incors GmbH.

This product includes software developed by the Apache Software Foundation (<http://www.apache.org/>).

© DevelopMentor

This product may include the JCifs library, for which the following notice applies:

JCifs © Copyright 2004, The JCIFS Project, is licensed under LGPL (<http://jcifs.samba.org/>). See the LGPL.txt file in the Third Party Software directory on the installation CD.

Avid Interplay contains components licensed from LavanTech. These components may only be used as part of and in connection with Avid Interplay.

Attn. Government User(s). Restricted Rights Legend

U.S. GOVERNMENT RESTRICTED RIGHTS. This Software and its documentation are "commercial computer software" or "commercial computer software documentation." In the event that such Software or documentation is acquired by or on behalf of a unit or agency of the U.S. Government, all rights with respect to this Software and documentation are subject to the terms of the License Agreement, pursuant to FAR §12.212(a) and/or DFARS §227.7202-1(a), as applicable.

Trademarks

Avid, the Avid Logo, Avid Everywhere, Avid DNXHD, Avid DNXHR, Avid NEXIS, Avid NEXIS | Cloudspaces, AirSpeed, Eleven, EUCON, Interplay, iNEWS, ISIS, Mbox, MediaCentral, Media Composer, NewsCutter, Pro Tools, ProSet and RealSet, Maestro, PlayMaker, Sibelius, Symphony, and all related product names and logos, are registered or unregistered trademarks of Avid Technology, Inc. in the United States and/or other countries. The Interplay name is used with the permission of the Interplay Entertainment Corp. which bears no responsibility for Avid products. All other trademarks are the property of their respective owners. For a full list of Avid trademarks, see: <http://www.avid.com/US/about-avid/legal-notices/trademarks>.

The following disclaimer is required by Apple Computer, Inc.:

APPLE COMPUTER, INC. MAKES NO WARRANTIES WHATSOEVER, EITHER EXPRESS OR IMPLIED, REGARDING THIS PRODUCT, INCLUDING WARRANTIES WITH RESPECT TO ITS MERCHANTABILITY OR ITS FITNESS FOR ANY PARTICULAR PURPOSE. THE EXCLUSION OF IMPLIED WARRANTIES IS NOT PERMITTED BY SOME STATES. THE ABOVE EXCLUSION MAY NOT APPLY TO YOU. THIS WARRANTY PROVIDES YOU WITH SPECIFIC LEGAL RIGHTS. THERE MAY BE OTHER RIGHTS THAT YOU MAY HAVE WHICH VARY FROM STATE TO STATE.

Avid NEXIS Setup and Maintenance Guide • Revised July 2020 • This document is distributed by Avid in online (electronic) form only, and is not available for purchase in printed form.

Revision History

Date	Avid NEXIS FS Version	Description of Changes
March 2021	2021.3.0	Updated system drive capacities
July 2020	2020.5.0	Added Avid NEXIS FS description, cautions when adding Engines to an existing system . Some document restructuring.
May 2020	2020.5.0	Avid NEXIS All-Mirror support
April 2020	2020.3.0	USM version 1.37 or 1.37a factory installed on G2 labeled Controllers
March 2020	2020.3.0	Updated specs for Avid NEXIS E5 chassis and change to default Agent password
12/19/2019	(Update)	Strengthened caution to lock all E5 drives
10/29/2019	2019.10.0	Added new Controller types (USM 1.37 and 32GB memory)
06/30/2019	2019.6.0	Additional drive size support for Avid NEXIS E2 SSD

Contents

Using This Guide	vii
Symbols and Conventions	vii
If You Need Help	viii
Accessing the Online Documentation	viii
Avid Training Services	viii
Chapter 1 Avid NEXIS System Overview	1
Avid NEXIS Platforms	1
System Director Functionality	2
Supported Configurations	3
System and Component Details	5
Engine and SDA Serial Number Location	5
2U Chassis Front Details	5
2U Chassis Rear Details	6
4U Chassis Front Details	8
4U Chassis Rear Details	8
Control Panel for all 2U and 4U Chassis	9
5U Chassis Front View and Details	10
5U Chassis Drive Drawer and Sideplane Status Panel	11
5U Chassis Drive Slot Numbering	12
5U Chassis Rear View Details	13
Types of Controllers	13
Controller Functionality and Restrictions	18
Media Pack and System Drives	19
Power Supplies	22
Chapter 2 Connecting the Equipment	27
Rack Mounting Guidelines and Requirements	27
Mounting the Engine or System Director Appliance	27
Installing the Media Packs (2U and 4U Chassis)	31
Installing Media Pack Drives (5U Chassis)	31
Connecting Power to Equipment	32
Connecting the Hardware to a Switch	33
Enabling Link Aggregation	35
Chapter 3 Software Installation and System Setup	37
System Setup Information	37
Understanding the Shared Name Space	38
What is DNS?	39

What is NTP?	39
Installing and Setting Up the System	39
Registering the System and Downloading the Avid NEXIS Software	40
Configuring the Computer's IP Address	40
Installing the Software and Setting up the Avid NEXIS System	43
Chapter 4 Adding and Replacing Hardware	48
Collecting Logs for Customer Care	48
Understanding Hardware Faults	48
Expanding a System	49
Adding an Engine to Your Infrastructure	49
Adding Media Packs to an Engine	50
About Drive Failures	51
Identifying the Slot Number for a Failing or Failed Drive	52
Replacing a Drive	52
Power Supply Failures	55
Replacing a Power Supply (2U and 4U)	55
Replacing a Power Supply (5U)	56
Replacing a Cooling Module (5U only)	57
Installing a Redundant Controller	57
Dual Controller Connection Diagrams	59
About Controller Failures	60
Replacing a Controller	61
Removing or Replacing a Chassis	61
Chapter 5 Specifications and Notices	63
Physical	63
Electrical and Power	63
Altitude and Temperature	64
Shock, Vibration and Noise	64
Approvals	65
Uninterruptible Power Supply (UPS)	65
Warnings and Cautions	66
Proposition 65 Warning	66
FCC Notice	66
Class A Equipment	67
Class B Equipment	67
Modifications	67
Cables	67
Canadian Notice (Avis Canadien)	67
Class A Equipment	67
Class B Equipment	68





LED Safety Notices	68
European Union Declaration of Conformity.....	68
Disposal of Waste Equipment by Users in the European Union	70
Argentina Conformity.....	70
Australia and New Zealand EMC Regulations.....	70
Japan EMC Regulations	70
Class A Equipment	70
Korean EMC Regulations.....	71
Class A Equipment	71
Taiwan EMC Regulations.....	71
Index	76

Using This Guide

The Avid NEXIS® media network provides a high-performance distributed file system that contains high-capacity shared media storage for workgroups of connected Avid® editing workstations.

Symbols and Conventions

Avid documentation uses the following symbols and conventions:

Symbol or Convention	Meaning or Action
	A note provides important related information, reminders, recommendations, and strong suggestions.
	A caution means that a specific action you take could cause harm to your computer or cause you to lose data.
	A warning describes an action that could cause you physical harm. Follow the guidelines in this document or on the unit itself when handling electrical equipment.
	A user tip provides a helpful hint that can aid users in getting the most from their system.
	A shortcut shows the user keyboard or mouse shortcuts for a procedure or command.
>	This symbol indicates menu commands (and subcommands) in the order you select them. For example, File > Import means to open the File menu and then select the Import command.
▶	This symbol indicates a single-step procedure. Multiple arrows in a list indicate that you perform one of the actions listed.
(Windows), (Windows only), (Macintosh), or (Macintosh only)	This text indicates that the information applies only to the specified operating system, either Windows or Macintosh OS X.
Bold font	Bold font is primarily used in task instructions to identify user interface items and keyboard sequences.
<i>Italic font</i>	Italic font is used to emphasize certain words and to indicate variables.
Courier Bold font	Courier Bold font identifies text that you type.
Ctrl+key or mouse action	Press and hold the first key while you press the last key or perform the mouse action. For example, Command+Option+C or Ctrl+drag.
(pipe character)	The pipe character is used in some Avid product names, such as MediaCentral Production Management. In this document, the pipe is used in product names when they are in headings or at their first use in text.

If You Need Help

If you are having trouble using your Avid product:

1. Retry the action, carefully following the instructions given for that task in this guide. It is especially important to check each step of your workflow.
2. Check the latest information that might have become available after the documentation was published.

New information is available in the ReadMe PDF document, available online.

Always check online for the most up-to-date release notes or ReadMe because the online version is updated whenever new information becomes available. To view the online versions, visit the Knowledge Base at www.avid.com/US/support.

3. Check the documentation that came with your Avid application or your hardware for maintenance or hardware-related issues.
4. Visit the online Knowledge Base at www.avid.com/US/support. Online services are available 24 hours per day, 7 days per week. Search this online Knowledge Base to find answers, to view error messages, to access troubleshooting tips, to download updates, and to read or join online message-board discussions.

Accessing the Online Documentation

The Avid online documentation contains all the product documentation in PDF format and Help files where relevant. You can access the documentation on the Knowledge Base page for your release. Download and install Acrobat Reader before you access the PDF documentation.

Avid Training Services

Avid makes lifelong learning, career advancement, and personal development easy and convenient. Avid understands that the knowledge you need to differentiate yourself is always changing, and Avid continually updates course content and offers new training delivery methods that accommodate your pressured and competitive work environment.

For information on courses/schedules, training centers, certifications, courseware, and books, please visit www.avid.com/support and follow the Training links, or call Avid Sales at 800-949-AVID (800-949-2843).

1 Avid NEXIS System Overview

Avid NEXIS is a shared-storage solution for acquisition-, creative-, distribution-, and archive media workflows. Avid network storage systems are built for media and entertainment. They enable multiple clients to share, capture, play, and edit video and audio media.

Avid NEXIS uses Avid NEXIS | FS, a proprietary file system, which is scalable to support every media production team from individuals to the largest broadcast enterprises. As your storage needs grow, you can add more Media Packs and Engines to the same file system, seamlessly combining all the storage into one centrally-managed system.

Clients access Avid NEXIS systems through external switch connections. The Avid NEXIS Management Console provides full system management.

This chapter provides an overview of the Avid NEXIS system and the basic function of each component. Other chapters in this guide describe how to install the system in a rack, connect the power and Ethernet cables, and configure the system.

Avid NEXIS Platforms

The Avid NEXIS system is available in the following hardware platforms. For more information, see [“System and Component Details” on page 5](#).

Model	Size	Features
Avid NEXIS PRO (20TB) Avid NEXIS PRO (40TB)	2U	One Controller, two 764W power supply/cooling modules (PCMs), two solid state system drives, and one Media Pack (10 drives), of either 2TB drives (yielding a 20TB Media Pack) or 4TB drives (yielding a 40TB Media Pack)
Avid NEXIS E2 SSD	2U	One Controller, two 764W power supply/cooling modules (PCMs), two solid state system drives, and one SSD Media Pack (10 drives)
Avid NEXIS E2, Avid NEXIS E2 All-Mirror	2U	One or two Controllers, two 764W power supply/cooling modules (PCMs), two solid state system drives, and one Media Pack (10 drives)
Avid NEXIS E4, Avid NEXIS E4 All-Mirror	4U	One or two Controllers, four 580W power supply/cooling modules, two solid state system drives, and up to two Media Packs (20 drives) Empty drive slots must be covered with blank plates to maintain proper airflow and cooling.
Avid NEXIS E5, Avid NEXIS E5 All-Mirror	5U	One or two Controllers with 40GbE NICs, two 2200W power supplies, two solid state system drives, five fan modules, up to eight Media Packs (80 drives) and two spare media drives.
Avid NEXIS E5 NL	5U	One or two Controllers with 10GbE NICs, two 2200W power supplies, two solid state system drives, five fan modules, up to eight Media Packs (80 drives) and two spare media drives.

Model	Size	Features
System Director Appliance (SDA)	2U	<p>Server built from common hardware modules as other Avid NEXIS products. Contains one or two Controllers, two 764W power supply/cooling modules, and two solid state system drives.</p> <p>The System Director Appliance does not provide media storage; the unused drive slots are covered with blank plates.</p> <p>The System Director Appliance must be used with:</p> <ul style="list-style-type: none"> • Any Enterprise configuration with more than four Media Packs • Any configuration that includes Avid NEXIS E5 or Avid NEXIS E5 NL • Any configuration that is intended to support Media Mirroring, and with All-Mirror Engines <p>Cannot be used with Avid NEXIS PRO.</p>

System Director Functionality

The System Director maintains all information about the Avid NEXIS file system.

The System Director is either embedded on a Controller in an Engine, or runs separately on a System Director Appliance. In any Avid NEXIS configuration, there is only one System Director. If the System Director is embedded, the first Engine configured in a multi-Engine system runs the System Director for the entire system.

The embedded System Director can manage up to four Media Packs.

The System Director Appliance can manage more than four Media Packs, up to the limit described in the *Avid NEXIS ReadMe*, with either the Avid NEXIS | FS Extended license or the Avid NEXIS | FS Advanced license. The System Director Appliance cannot be used with an Avid NEXIS | PRO.

The System Director:

- Manages the metadata by storing directory information and file attributes.
- Provides a location to coordinate file access modes (read/write), file locking, range locking, performance data collection, logging, file lookup, and directory change tracking for client systems.
- Provides the following information:
 - Identity of all connected storage systems
 - Information about the drives, power, cooling and Controllers in the configuration
 - Names of workspaces
 - Lists of users and groups within the system

The System Director does not store client data (media files); these are stored on the Media Packs (drives) within one or more Engines. System Director metadata is mirrored on the system drives in the Engines or in the System Director Appliance.

System Directors, workgroup servers, and clients must all be synchronized with a common time of day. For information on setting the Network Time Protocol (NTP), see [“Software Installation and System Setup” on page 37](#).

Supported Configurations

The Avid NEXIS hardware can be configured into a single shared storage system, using a single name space, in any of the following ways.

Configurations with an Embedded System Director

All configurations running an embedded System Director use the Avid NEXIS | FS Foundation license.

Avid NEXIS Model	Functionality
Avid NEXIS PRO 20TB and 40TB	<p>Provides media storage and runs the System Director. Can manage up to four Media Packs (four Avid NEXIS PRO Engines).</p> <p>Avid NEXIS PRO cannot be combined with Avid NEXIS E-series (Enterprise class) Engines or the System Director Appliance.</p> <p>Supports up to 30 connected clients, 24 of which can be active at the same time.</p> <p>Supports a single Controller.</p>
Avid NEXIS E2 SSD	<p>Provides media storage and runs the System Director. Can be combined with Avid NEXIS E2, Avid NEXIS E2 SSD, and Avid NEXIS E4, up to a total of four Media Packs. For more than four Media Packs deploy a System Director Appliance.</p> <p>Supports one or two Controllers.</p> <p>Avid NEXIS E2 SSD cannot be combined with Avid NEXIS PRO Engines.</p>
Avid NEXIS E2	<p>System Director runs on the Avid NEXIS E2 Engine, which also provides storage. Can be combined with Avid NEXIS E2, Avid NEXIS E2 SSD and Avid NEXIS E4, up to a total of four Media Packs. For more than four Media Packs deploy a System Director Appliance.</p> <p>Supports one or two Controllers.</p> <p>Supports up to 40 clients.</p>
Avid NEXIS E4	<p>System Director runs on the Avid NEXIS E4 Engine, which also provides storage. Can be combined with Avid NEXIS E2, Avid NEXIS E2 SSD and Avid NEXIS E4, up to a total of four Media Packs. For more than four Media Packs deploy a System Director Appliance.</p> <p>Supports one or two Controllers.</p> <p>Supports up to 40 clients.</p>

Configurations with an External System Director (System Director Appliance)

The System Director Appliance runs the System Director (but does not provide media storage) for configurations that exceed the limits of the embedded System Director. The System Director Appliance uses either the Avid NEXIS | FS Extended license or the Avid NEXIS | FS Advanced license, depending on how many Media Packs or clients you want to manage. See the *Avid NEXIS ReadMe* for license details.

A System Director Appliance is required in the following configurations:

- More than four Media Packs (in any combinations of Avid NEXIS | E2, Avid NEXIS | E2 SSD, and Avid NEXIS | E4 Engines)
- Any configuration that is intended to support Media Mirroring, and with any Avid NEXIS All-Mirror Engines
- Any configuration that includes Avid NEXIS | E5 or Avid NEXIS | E5 NL Engines

The System Director Appliance cannot be used with Avid NEXIS | PRO.

Engine Protection (Media Mirroring) Configurations

Mirrored Workspaces protect against the failure of an entire Engine (all of its Media Packs) by duplicating (or mirroring) the Workspace data onto other Media Packs in separate Engines. In the event of an Engine failure, the Workspace remains usable with no data loss.

Mirrored Workspaces are supported with an System Director Appliance and at least three of the following in the same Storage Group:

- Avid NEXIS | E2 Engines
- Avid NEXIS | E2 SSD Engines
- Avid NEXIS | E4 Engines
- Avid NEXIS | E5 Engines

All the Engines in the configuration must have the same number and capacity of Media Packs, and all must be running Avid NEXIS | FS version 7.0 or higher. All of the Media Packs must be added to the same Storage Group, which then becomes mirror capable. In the Management Console on the Storage Groups page, when the Storage Group contains the correct number of Media Packs in equivalent Engines, the Mirror Capable column displays a Yes.



Mirrored Workspaces are not supported on Avid NEXIS | E5 NL systems or those running an embedded System Director.

For more information, see the *Avid NEXIS Administration Guide*.

All-Mirror Configurations

An Avid NEXIS All-Mirror configuration consists of a System Director Appliance and three or more of the following in their own All-Mirror Storage Group:

- Avid NEXIS | E2 All-Mirror Engines
- Avid NEXIS | E4 All-Mirror Engines
- Avid NEXIS | E5 All-Mirror Engines

Each All-Mirror Engine must contain the same number and capacity of Media Packs. All-Mirror Storage Groups can belong to the same shared-storage system as other Storage Groups.

See the *Avid NEXIS Administration Guide* for details and restrictions about managing an All-Mirror Storage Group.

System and Component Details

The Avid NEXIS Engines and the System Director Appliance are rack-mountable units housing the other system components (drives, Controllers, and power supplies). If a component fails, the Avid NEXIS shared-storage system is designed to remain operational while you replace it. Do not shut down an Engine or the System Director Appliance to replace a failed part.

Data passes between the Engine and clients through a switch connected to the Engine with one or more 10 Gb or 40 Gb Ethernet connections. These connections provide clients access to the data on the media drives.

Engine and SDA Serial Number Location

On all Avid NEXIS Engines (Enterprise and PRO) and the System Director Appliance, the chassis serial number is printed on a label attached to the left rear chassis mounting ear. The following figure shows the location of the serial number label on an Avid NEXIS | E4.

Serial Number Label Location



2U Chassis Front Details

The front of a 2U chassis has a removable bezel (not shown). Removing the bezel allows access to the drive slots. The 2U Engine supports one Media Pack (10 drives) for media storage and two system drives. The System Director Appliance supports two system drives.

As shipped from Avid, the system drives occupy the first two slots (0 and 1). Drive slot numbering for storage engines is shown below.



In the System Director Appliance, the empty slots are covered with blank plates for proper airflow and cooling.



2U Chassis Rear Details

The rear of the chassis provides access to the Controller and PCMs.

In Avid NEXIS | E2, Avid NEXIS | E2 All-Mirror, and the System Director Appliance the Controller is in slot 0 (top).

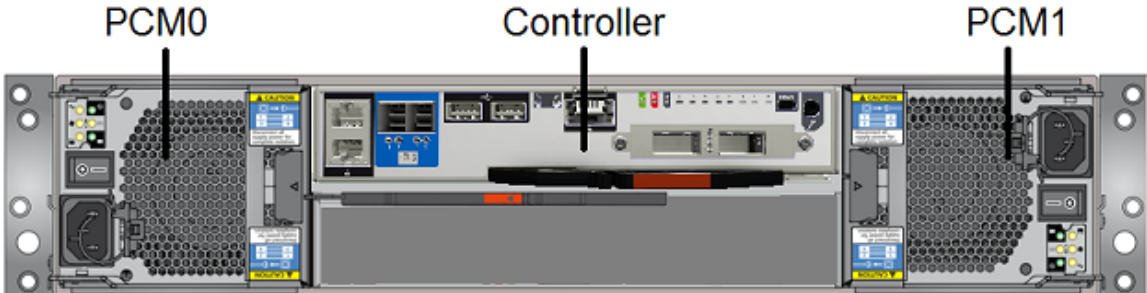

In an Avid NEXIS | PRO 20TB, the Controller is located in slot 0 (top), as shown. this type of Controller has no identification label, and the Host Fabric section is purple.

Avid NEXIS | PRO 20TB Rear View

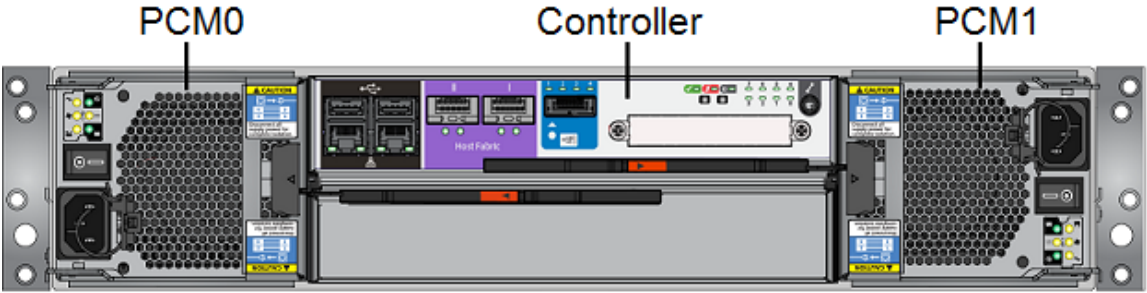

In Avid NEXIS | E2 SSD the Controller is upside-down in slot 1 (bottom).

Avid NEXIS | E2 SSD Rear View

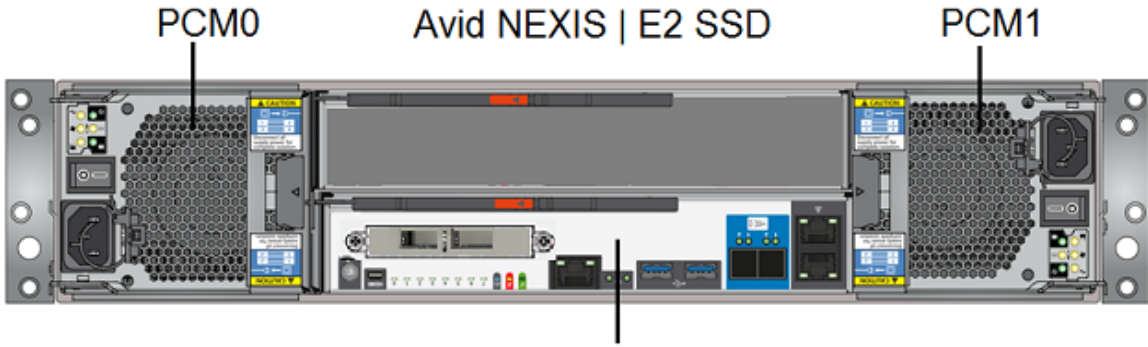

Controller MUST be upside down in slot 1 (Bottom Slot)

In an Avid NEXIS | PRO with a Media Pack of 4TB SATA drives, the Controller is always located in slot 1 (bottom), and is installed upside down so the internal connectors align correctly. An Avid NEXIS | PRO 40TB can use one of two types of Controllers, as shown.

Avid NEXIS | PRO 40TB with Purple Fascia Controller in Slot 1

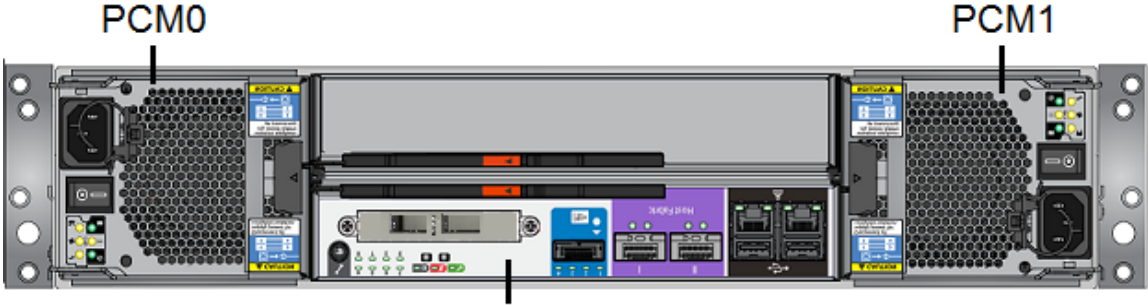

Controller

Avid NEXIS | PRO 40TB with Controller 10 in Slot 1



Controller

Rear View Features of 2U Chassis

Component	Notes
Power Supply/Cooling Modules (PCM)	764W power supply and cooling fan modules. The left power supply is numbered 0, the right is numbered 1, in event and error messages.
Controller	Avid NEXIS PRO (2TB drives)—Uses one Controller in slot 0 only Avid NEXIS PRO (4TB drives)—Uses one Controller in slot 1 only , upside down (can be one of two types of Controllers) Redundant controllers not supported in any Avid NEXIS PRO. Avid NEXIS E2 SSD uses only one Controller, which must be upside down in slot 1 (bottom slot). Avid NEXIS E2 and System Director Appliance can use one or two (redundant) Controllers. The second Controller is upside down in slot 1 (bottom slot).

4U Chassis Front Details

The front of the 4U chassis has a removable bezel (not shown). Removing the bezel allows access to the drive slots. The 4U chassis supports two Media Packs (10 drives each) for media storage and two system drives. As shipped from Avid, the system drives occupy the first two slots in the Engine (0 and 1). Drive slot numbering is shown below.

The drives in the 4U chassis are numbered from top left (0) to bottom right (23), as shown.



4U Chassis Rear Details

The rear of the 4U chassis provides access to the Controllers and the PCMs. If you use a redundant Controller, it must be installed in the third slot from the top (slot 2), as shown.

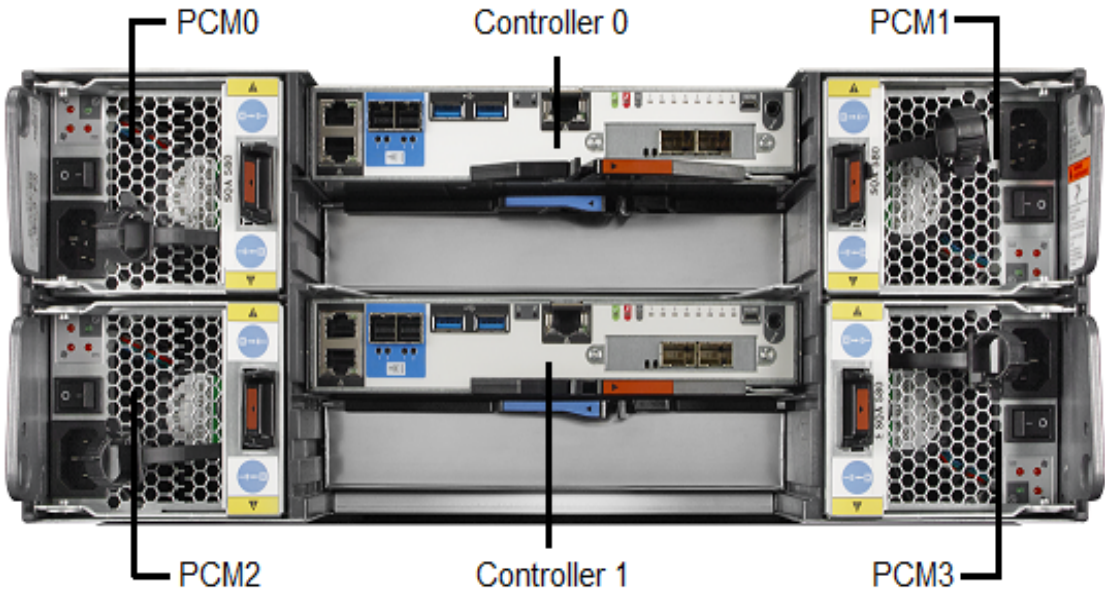

Rear View Features of 4U chassis

Component	Notes
Power/Cooling Module (PCM)	Four 580W PCMs (as viewed from the rear, PCM 0=top left, PCM 1=top right, PCM 2=bottom left, PCM 3=bottom right)
Storage Controller	In a single Controller configuration, it must be installed in the top slot (identified in error and status messages as Controller 0). If a second Controller is installed, it is identified as Controller 1.

Control Panel for all 2U and 4U Chassis

The following figure shows the control panel on the left side of the chassis on all 2U and 4U chassis.

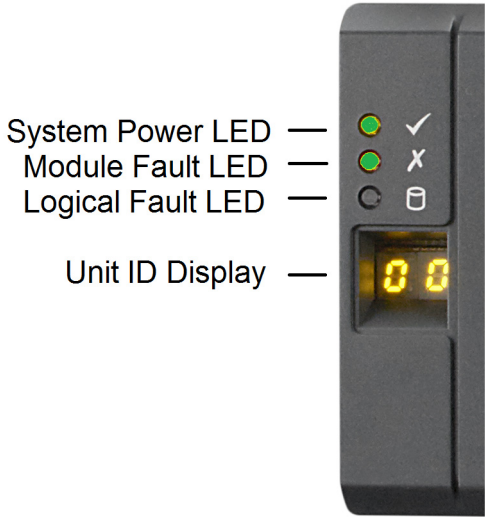

Control Panel Features on all 2U and 4U Chassis

Description	Status/Purpose
System Power LED	Green when system is on (operational). Amber when system is in standby mode (not operational).
Module Fault LED	Amber when there is a system hardware fault. In that case, another LED on the faulty component may be lit.
Logical Fault LED	Amber when something other than the enclosure management system (usually a drive) fails.
Enclosure ID Display	Displays the enclosure identification number (optional; useful with multiple enclosure systems)

5U Chassis Front View and Details

On 5U chassis, the bezels are attached at the factory and do not need to be removed for any system maintenance procedures. The 5U chassis has two drive drawers, each holding 42 drives. The front of the chassis has two status panels, as described below and shown in the following figure:

- Drive drawer and sideplane status panel (two on each drive drawer)

The LED lights when a drive has failed, indicating the drawer and slot of the drive. For details, see [“5U Chassis Drive Drawer and Sideplane Status Panel”](#) on page 11.

- Engine status and control panel

Indicates the overall status and fault conditions of the Engine.



5U Chassis Status and Control Panel

The 5U chassis has a Status and Control panel that indicates the overall status of the engine and has the following features.

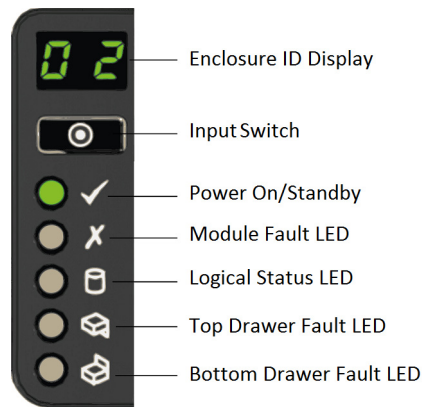

Description	Status/Purpose
Enclosure ID display	Displays the enclosure identification number (optional; helps you locate the engine in a high-density rack or cabinet populated with several other similar systems).
Input Switch	Sets the Enclosure ID display.
Power On/Standby	Green when system is on (operational). Amber when system is in standby mode (not operational).
Module Fault indicator	Amber when there is a system hardware fault. In that case, another LED on the faulty component may be lit.
Logical Status indicator	When lit, indicates that a drive has failed. To determine the location of the failed drive, see the drive status indicator panels on the Engine.
Top Drawer fault indicator	When amber, indicates a fault in the top drawer (drive, cable, or fan).
Bottom Drawer fault indicator	When amber, indicates a fault in the bottom drawer (drive, cable, or fan)

5U Chassis Drive Drawer and Sideplane Status Panel

The drive drawer and sideplane status panel indicates the health of the drives, and shows drive activity.

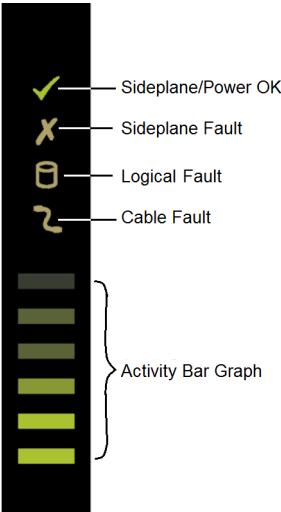

Description	Status/Purpose
Sideplane and Power OK	Green when the sideplane card is working and there are no power problems
Sideplane Fault	Amber if a drive has failed
Logical Fault	Flashes amber if one or more RAID sets have failed drives
Cable Fault	Amber if the cable between the drawer and the back of the enclosure has failed
Activity bar graph	Shows the amount of data I/O from zero segments lit (no I/O) to all six segments lit (maximum I/O)

5U Chassis Drive Slot Numbering

The 5U chassis has two drawers for the system and Media Pack drives. Drive slot numbering is shown in the following figure.

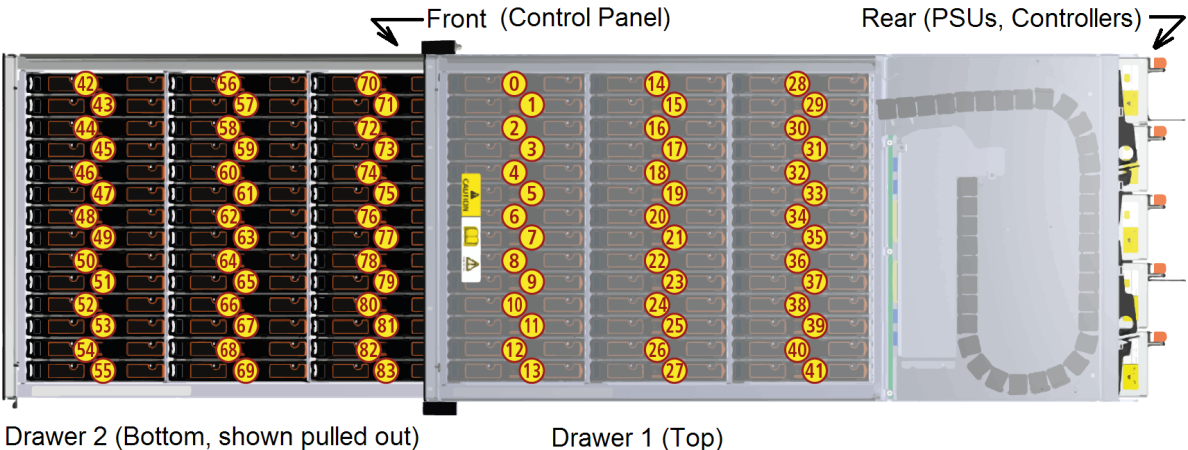

5U Chassis Rear View Details

The rear of the 5U chassis provides access to the Controllers, power supplies, and fans. In a single-Controller configuration, the Controller can be in either slot but Avid recommends keeping it in the left-hand slot (Controller 0 in the figure below).

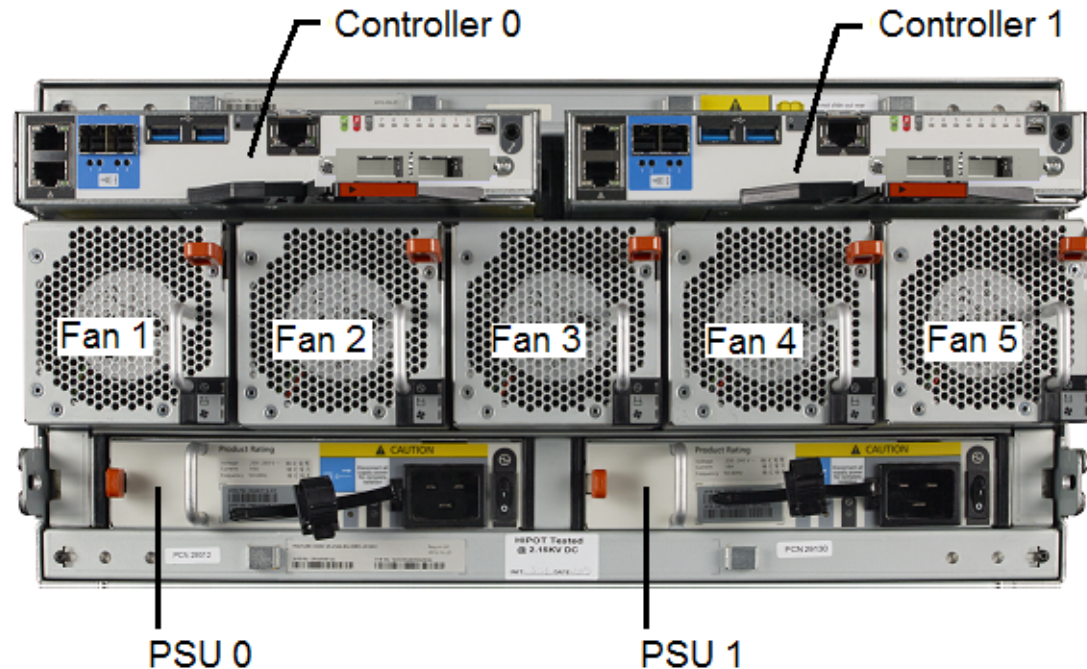

Component	Notes
Controller 0, Controller 1	<p>If only one controller is present, it is typically in the left slot. Controllers are identified in error and status messages as 0 (left) and 1 (right).</p> <p>If a second Controller is installed, it is identified as Controller 1.</p> <p>Avid NEXIS E5 NL comes with a QSFP to SFP+ adapter to connect 10GbE SFP+ optics or cables to a switch.</p>
Fans 0 through 4	Five cooling fans, identified in error and status messages as 0 (left) through 4 (right)
PSU 0, PSU 1	Power supply modules, identified in error and status messages as 0 (left) and 1 (right)

Types of Controllers

Depending on your Avid NEXIS model, the Engine or System Director Appliance supports one or two of the following Controllers.



Both Controllers in an Engine must be the same type, with the same label.

Controller Type ^a (Label)	Technical Details	Used in and Supported Slots
Avid NEXIS PRO Controller (no label)	Four cores with 16GB memory Supports a 10GbE switch connection	Avid NEXIS PRO 20TB Slot 0 (top) only Avid NEXIS PRO 40TB Slot 1 (bottom) only, upside down
Controller 10	Six cores with 16GB memory Supports a 10GbE switch connection	Avid NEXIS E2 Both slots (upside down in bottom slot) Avid NEXIS PRO 40TB Slot 1 (bottom) only, upside down
Controller PRO 40 G2	Six cores with 16GB memory USM version 1.37/1.37a factory installed Supports a 10GbE switch connection	Avid NEXIS PRO 40TB Slot 1 (bottom) only, upside down
Avid NEXIS PRO 40/E2	Six cores with 32GB memory USM version 1.37/1.37a factory installed Supports a 10GbE switch connection	Avid NEXIS E2 Both slots (upside down in bottom slot) Avid NEXIS PRO 40TB Slot 1 (bottom) only, upside down
Avid NEXIS PRO 40 G2/E2 G2	Six cores with 32GB memory USM version 1.37/1.37a factory installed Supports a 10GbE switch connection	Avid NEXIS PRO 40TB Slot 1 (bottom) only, upside down Avid NEXIS E2 Both slots (upside down in bottom slot)
Controller E2 G2	Six cores with 32GB memory USM version 1.37/1.37a factory installed Supports a 10GbE switch connection	Avid NEXIS E2 Both slots (upside down in bottom slot) Avid NEXIS PRO 40TB Slot 1 (bottom) only, upside down
Avid NEXIS E2 SSD Controller	Six cores with 16GB memory Supports a 40GbE switch connection	Avid NEXIS E2 SSD Slot 1 (bottom) only, upside down
Avid NEXIS E2 SSD G2	Six cores with 32GB memory USM version 1.37/1.37a factory installed Supports a 40GbE switch connection	Avid NEXIS E2 SSD Slot 1 (bottom) only, upside down
Avid NEXIS E2 SSD G2	Six cores with 32GB memory USM version 1.37/1.37a factory installed Supports a 40GbE switch connection	Avid NEXIS E2 SSD Slot 1 (bottom) only, upside down

Controller Type ^a (Label)	Technical Details	Used in and Supported Slots
Controller 20/SDA	Eight cores with 32GB memory Supports a 10GbE switch connection	Avid NEXIS E4 Slots 0 (top) and 2 (third from top) System Director Appliance Both slots (upside down in bottom slot)
Avid NEXIS E4 G2/SDA G2	Eight cores with 32GB memory USM version 1.37/1.37a factory installed Supports a 10GbE switch connection	Avid NEXIS E4 Slots 0 (top) and 2 (third from top) System Director Appliance Both slots (upside down in bottom slot)
Controller 80	Twelve cores with 128GB memory Supports a 40GbE switch connection	Avid NEXIS E5 Both slots (left and right)
Avid NEXIS E5 G2	Twelve cores with 128GB memory USM version 1.37/1.37a factory installed Supports a 40GbE switch connection	Avid NEXIS E5 Both slots (left and right)
Controller E5 NL	Twelve cores with 128GB memory Supports a 10GbE switch connection	Avid NEXIS E5 NL Both slots (left and right)
Avid NEXIS E5 NL G2	Twelve cores with 128GB memory USM version 1.37/1.37a factory installed Supports a 10GbE switch connection	Avid NEXIS E5 NL Both slots (left and right)

a. Installing a 16GB Controller and a 32GB Controller in the same Engine is not recommended.

You can optionally order and install a redundant Controller for certain Avid NEXIS Engines and the System Director Appliance. If ordered at the same time, it is shipped with the Engine but not factory installed.

Controller (Purple Fascia) for Avid NEXIS | PRO 20TB and 40TB

Avid NEXIS | PRO chassis with 2TB drives and some chassis with 4TB drives use a Controller with the following features. The Host Fabric section of the fascia is purple, which helps distinguish it from the other Controller (called the Controller 10) used in other Avid NEXIS | PRO 40TB systems.

Callouts shaded gray are not used but are identified for reference.

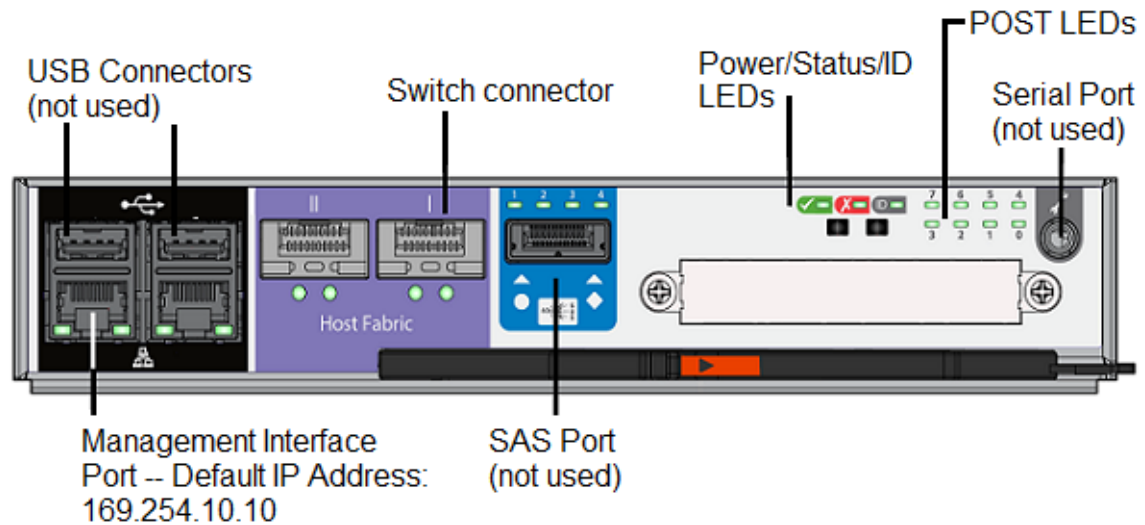

 In Avid NEXIS versions prior to v2021.3.0, after the system completes its boot cycle, all LEDs on the back of the Controller remain on. In Avid NEXIS version v2021.3.0 and later, after the boot cycle all LEDs on the back of the Controller turn off.

Avid NEXIS | PRO Purple Fascia Controller Features

Component	Notes
USB Connectors	(Shown for reference only. Not used)
Switch Connector	QSFP 10GbE port to connect to a network switch. See “Connecting the Hardware to a Switch” on page 33.
Power/OK, Fault, and ID LEDs	Power/OK: Green when the controller is operating correctly. Flashing green indicates a controller VPD error. Fault: Amber when the controller has a fault. ID: Blue when the controller is being identified.
POST LEDs	(Shown for reference only.)
Serial Port	(Shown for reference only. Not used)
Management Interface Port (left port only)	1GbE port for connecting the Controller to a laptop or other computer to install the Avid NEXIS software and initially configure the system. Default IP address is 169.254.10.10. The port LEDs indicate status as follows: Right side: <ul style="list-style-type: none"> Steady green: Link is active Flashing green: Network activity Left side—Network speed: <ul style="list-style-type: none"> Yellow: 1000Mb/s Green: 100Mb/s Off: 10Mb/s
SAS Port	(Shown for reference only. Not used)

Controllers for Avid NEXIS E-Series, SDA, and Avid NEXIS | PRO 40TB

The Controllers in Avid NEXIS E-Series engines and System Director Appliance, and some Avid NEXIS | PRO with 4TB drives look the same except for the label that identifies the controller type, and which slot it is in.

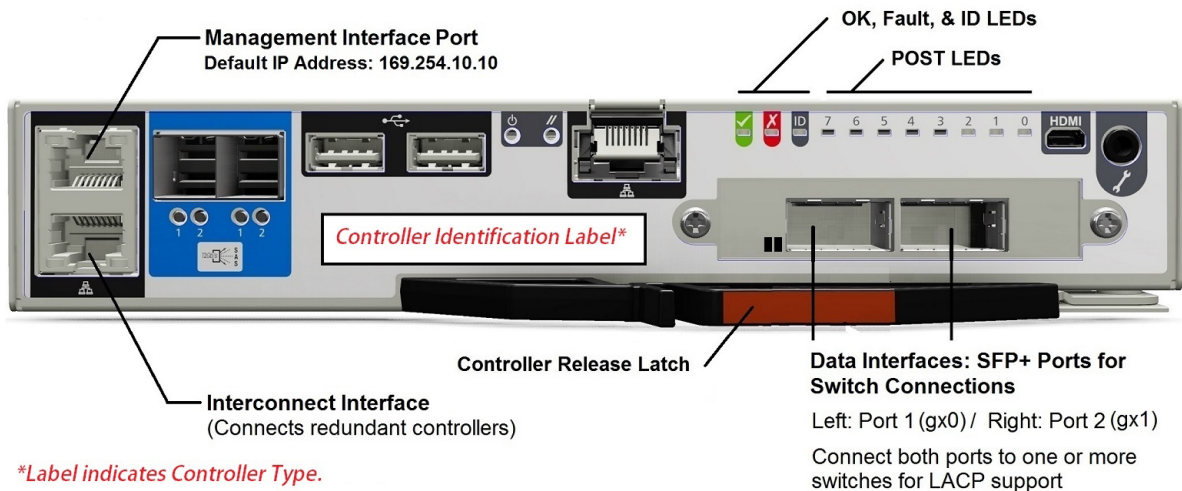

 Features that are not identified in the figure and table are not used in the Avid NEXIS implementation. Do not connect anything to unidentified ports.

 In Avid NEXIS versions prior to v2021.3.0, after the system completes its boot cycle, all LEDs on the back of the Controller remain on. In Avid NEXIS version v2021.3.0 and later, after the boot cycle all LEDs on the back of the Controller turn off.

Avid NEXIS E-Series Controller Features

Description	Purpose
Management Interface port, Interconnect Interface port	<p>The Management Interface port is used to connect to a laptop or other computer to install the Avid NEXIS software and initially configure the system. Default IP address is 169.254.10.10.</p> <p>The port has the following LEDs:</p> <p>Right side:</p> <ul style="list-style-type: none"> Steady green: Link is active Flashing green: Network activity <p>Left side—Network speed:</p> <ul style="list-style-type: none"> Yellow: 1000Mb/s Green: 100Mb/s Off: 10Mb/s <p>The Interconnect Interface port is used to connect two Controllers. See “Installing a Redundant Controller” on page 57.</p>

Description	Purpose
Power/OK, Fault, and ID LEDs	Power/OK: Green when the controller is operating correctly. Flashing green indicates a controller error. Fault: Amber when the controller has a fault. ID: Blue when the controller is being identified.
POST LEDs	Shows the boot progress of the controller. If the controller fails to boot, the LEDs show the stage in which the error occurred.
Controller identification label	Indicates the Controller type, which specifies in which Engine it can be used. See “Types of Controllers” on page 13 for more information.
Controller Release Latch	Disconnects the Controller from the backplane for removal from the Engine (see “About Controller Failures” on page 60).
Data Interface ports (SFP+)	Connects the Engine or System Director Appliance to a network switch (see “Connecting the Hardware to a Switch” on page 33). For a single port connection to a switch, use the left port (gx0). If using link aggregation (NIC teaming), connect both ports (gx0 and gx1) to one or more switches. LED states: Flashes green for link/activity, amber for fault.

Controller Functionality and Restrictions

The Controller provides the software management functionality, in some cases including the System Director (in Engines with an embedded System Director and on the System Director Appliance).

The Controller is turned on when the power supplies are on.

Controller (Agent) Password

Each Controller has its own Agent. Effective with Controllers manufactured after April 1, 2020, the default Agent password for a Controller is the last eight characters of the serial number, which is printed on a label on the top of the Controller housing. For example, a Controller with serial number RMS1013034G085N has a default Agent password of 034G085N. To see the serial number, you must partially remove the Controller from the Engine. See [“Replacing a Controller” on page 61](#) for how to remove a Controller.

The serial number-based default password replaces the previous default Agent password of **se-admin**. Use the new default Agent password when configuring a new Engine (see [“Installing the Software and Setting up the Avid NEXIS System” on page 43](#)).

Single vs Dual Controllers

The system can run with only one Controller (single controller configuration) or two (redundant controller configuration), which provides high availability.

If two Controllers are present, they divide the system services between them.



Both Controllers are active at the same time; there is no Active and Standby designation.

If one entire Controller fails, the System Director service (and other services) can switch over to the other one while the system keeps running. However, switchover does not occur if the network connection to a Controller fails. Switchover occurs only between Controllers in the same physical chassis, never between Controllers in different chassis.

16GB vs 32GB Memory Controllers

As of Avid NEXIS version 2019.10.0, Controllers with 16GB of memory (see [“Types of Controllers” on page 13](#)) in Avid NEXIS | E2 or Avid NEXIS | E2 SSD engines no longer support new activations of Avid NEXIS | Cloudspaces if they are also serving as the System Director for a shared-storage system. Avid NEXIS | E2 and Avid NEXIS | E2 SSD Controllers with 16GB of memory can be used in the storage-only Engines in a Cloudspaces configuration.

If you have an embedded System Director running on an Avid NEXIS | E2 or Avid NEXIS | E2 SSD and Cloudspaces is already activated, after you upgrade to Avid NEXIS version 2019.10.0 or higher a warning message is displayed in the Management Console advising you to upgrade the 16GB Controllers to a 32GB version (available as a fee-based upgrade) in the Engine running the System Director. You can continue to create and manage Cloudspaces (Workspaces) in an existing Cloudspaces configuration.

Media Pack and System Drives

A Media Pack is a set of 10 drives, all of which are the same capacity and type. The following table lists the Media Pack drives supported in Avid NEXIS Engines.

Avid NEXIS Model	Media Pack Drive Capacity	Drive Type
Avid NEXIS PRO 20TB	2TB (20TB Media Pack)	HDD
Avid NEXIS PRO 40TB	4TB (40TB Media Pack)	HDD
Enterprise (Online) / All-Mirror	2TB (20TB Media Pack)	HDD
<i>(Avid NEXIS E2, Avid NEXIS E4, Avid NEXIS E5, and their All-Mirror equivalents)</i>	4TB (40TB Media Pack)	
	6TB (60TB Media Pack)	
	10TB (100TB Media Pack)	
	14TB (140TB Media Pack)	
Avid NEXIS E5 NL	10TB (100TB Media Pack)	HDD
	12TB (120TB Media Pack)	
	16TB (160TB Media Pack)	
Avid NEXIS E2 SSD	960GB (9.6TB Media Pack)	SSD
	1.92TB (19.2TB Media Pack)	
	3.84TB (38.4TB Media Pack)	
	4TB (40TB Media Pack)	

When replacing a failed drive in a Media Pack, make sure to use a drive of the same capacity as, or larger than, the others in the Media Pack. For more information, see [“Replacing a Drive” on page 52](#) and the *Avid NEXIS Administration Guide*.

Avid NEXIS Engines and the System Director Appliance also have two SSD system drives, of the following *minimum* partition size (SSD capacity):

Avid NEXIS Model	System Drive Capacity
Avid NEXIS E2, Avid NEXIS E2 All-Mirror	200GB
Avid NEXIS E4, Avid NEXIS E4 All-Mirror	
Avid NEXIS PRO	
System Director Appliance	400GB
Avid NEXIS E2, Avid NEXIS E2 All-Mirror	
Avid NEXIS E2 SSD	
Avid NEXIS E4, Avid NEXIS E4 All-Mirror	
Avid NEXIS PRO	
Avid NEXIS E5, Avid NEXIS E5 All-Mirror	800GB
Avid NEXIS E5 NL	



If a system drive fails, Avid reserves the right to send a replacement of a size that meets or exceeds the minimum partition requirements.



Avid NEXIS SSD system drives cannot be removed from one system and used as a replacement in another system. The system drives are initialized as a mirrored pair during the manufacturing process. A new, replacement SSD from Avid has not been initialized in an Engine and is the only safe replacement for a failed system drive.

The System Director, whether running on an Engine or in the System Director Appliance, uses the system drives for metadata, startup files, and other system files. The Engine or System Director Appliance can run with one failed system drive. Avid recommends replacing it as soon as possible.

Typically, the system drives occupy slots 0 and 1 in the System Director Appliance and all Engines except the 5U chassis, and the Media Pack drives use the remaining slots. In 5U chassis, the system drives are typically in slots 28 (top drawer) and 70 (bottom drawer). However, there is no technical requirement for system drives to occupy any particular slots.

Drives are labeled as follows:

Label	Description
	System drive and SSD Media Pack drive labels include the capacity, the letters SS for solid state, and a manufacturer serial number.
	HDD Media Pack drive labels include the capacity, the abbreviation 7K2 indicating the drive speed (7200 RPM), and a manufacturer serial number.

SSDs (used as system drives in all Engines and as Media Pack drives in Avid NEXIS | E2 SSD) are physically 2.5” but are in a 3.5” carrier, like the HDDs.

Drives in the 2U, 4U Chassis and System Director Appliance



The drives used in the 2U and 4U chassis and System Director Appliance have a lock indicator and two LEDs that show the drive status, explained in the following figure and table.

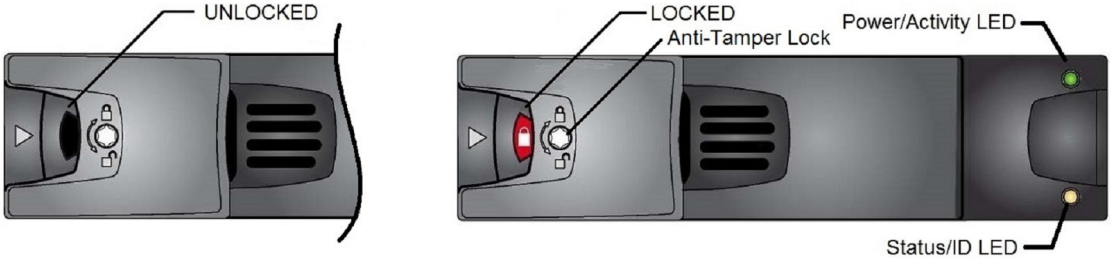

2U and 4U Drive Features

Feature	Status Indicator
Power and activity LED	Off—No power Blinking—I/O activity
Status and identification LED	Blinking 1 second on, 1 second off—To identify the drive On—Drive failed Off—OK

Drives in the 5U Chassis

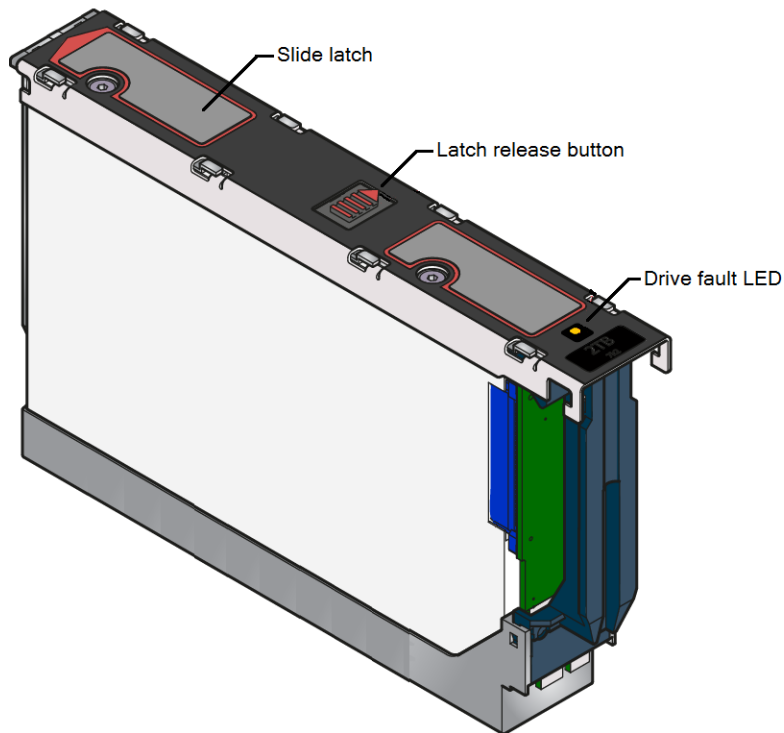

The drives in the Avid NEXIS | E5 and Avid NEXIS | E5 NL Media Packs have one LED that indicates a drive failure.



Leave failed drives in place until you have a replacement so you maintain the proper airflow. Obtain a replacement as soon as possible.

Power Supplies

Depending on your Avid NEXIS model, the Engine or System Director Appliance has the following number and type of power supply/cooling modules (PCMs) or power supply units (PSUs):

- Two 764W PCMs with integrated fans—2U chassis (Engines and SDA)
- Four 580W PCMs with integrated fans—4U chassis
- Two 2200W PSUs and five separate fans—5U chassis

The PCMs or PSUs are turned on when the power cord is plugged in and the power switch is on. They operate as follows:

Chassis	Operation
All 2U chassis	<p>1+1 redundant configuration, meaning the system remains running even if one PCM fails.</p> <p>For maximum protection from power loss, both PCMs must be plugged in to separate electrical circuits or separate UPS devices and turned on. With both PCMs plugged in and turned on, the system balances its power needs between them. If one PCM fails, the system can continue operating.</p>

Chassis	Operation
All 4U chassis	<p>2+2 redundant configuration, meaning the system remains running even if any two PCMs fail.</p> <p>For maximum protection from power loss, each pair of PCMs must be plugged in to separate electrical circuits or separate UPS devices (for example, two on circuit A and two on circuit B), and all must be turned on. With all four PCMs plugged in and turned on, the system balances its power needs among them.</p>
All 5U chassis	<p>1+1 redundant configuration, meaning the system remains running even if one PCM fails.</p> <p>Engine can run with only two of the five fans.</p> <p>Leave failed power supplies or fans in place until the replacement is ready to be installed to maintain proper airflow and cooling.</p>

764W PCM (All 2U Chassis including System Director Appliance)

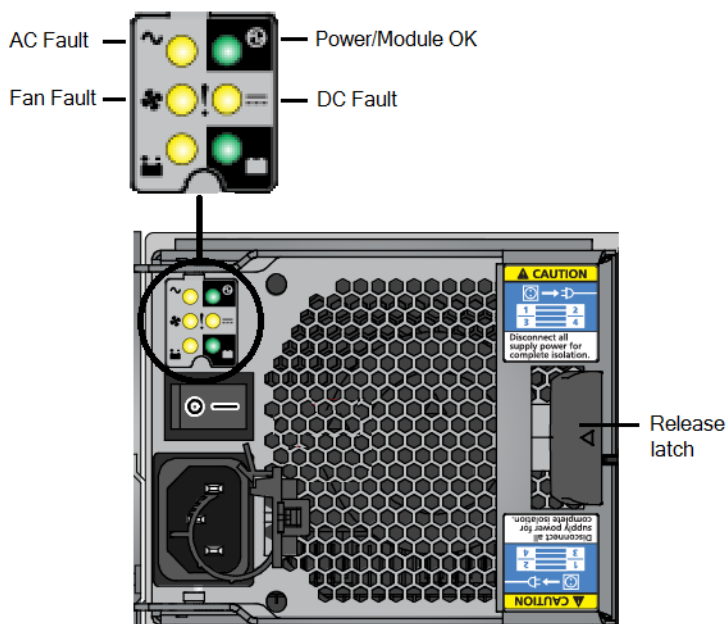

 *The bottom two LEDs, marked with battery icons, are not used.*

580W PCM (4U Chassis)

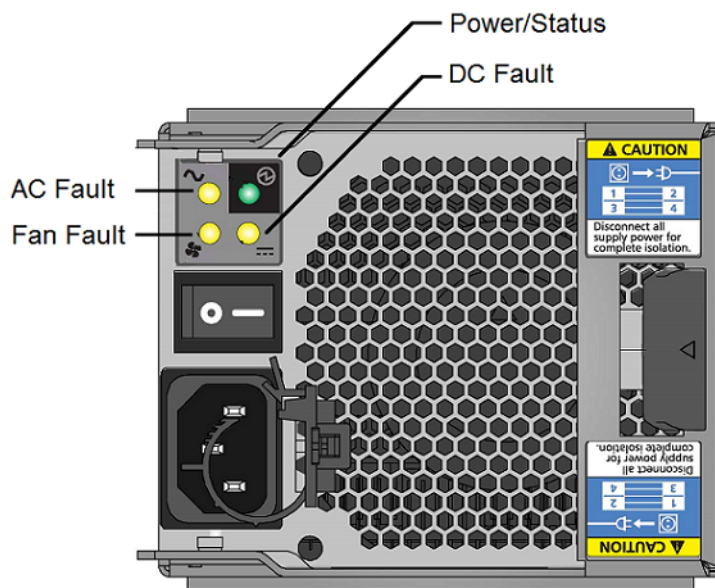

The LEDs on the 580W PCM work together to indicate overall module status; in the following table, for each row, all the LEDs must be in the listed state for the definition to apply.

580W Power Supply LED States

AC Fault	Fan Fault	Power/Module OK	DC Fault	Definition
---	---	---	---	No AC power on any PCM
On	---	---	On	No AC power on this PCM
---	---	On	---	AC present; PCM OK
---	---	On	On	PCM fan speed is outside acceptable limits
---	---	---	---	PCM fan has failed
On	On	---	On	PCM fault (over temperature, over voltage, or over current)
---	---	Flashing	---	Standby mode
Flashing	Flashing	---	Flashing	PCM firmware download in progress

 For readability, a series of dashes (---) means the LED is OFF.

2200W PSU (5U Chassis)

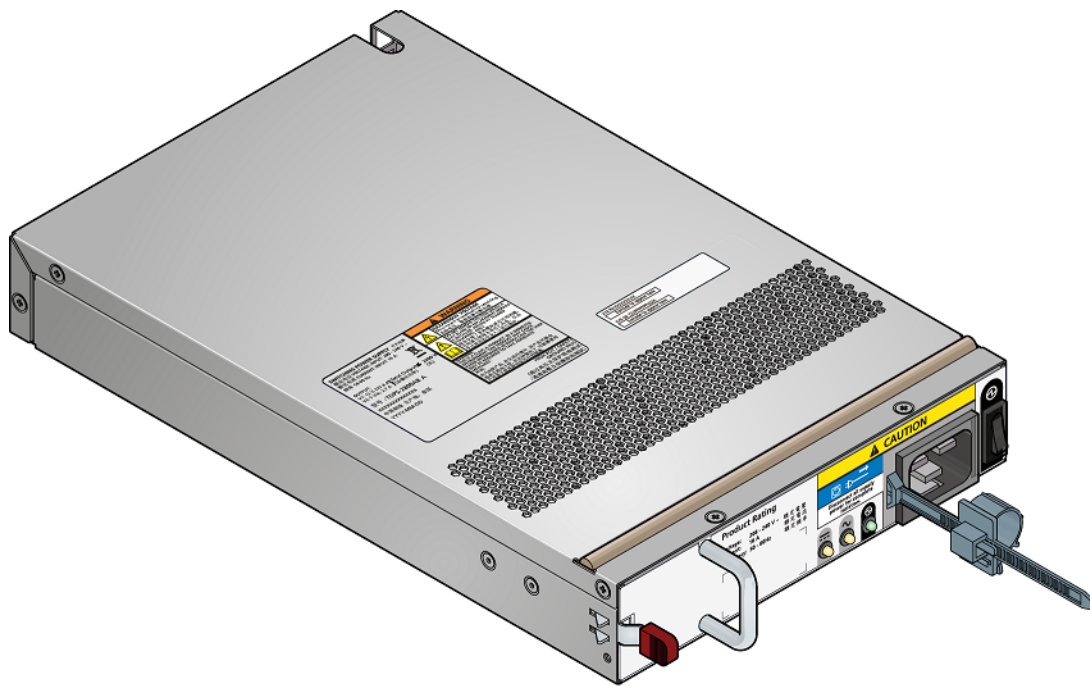

2200W PSU Details

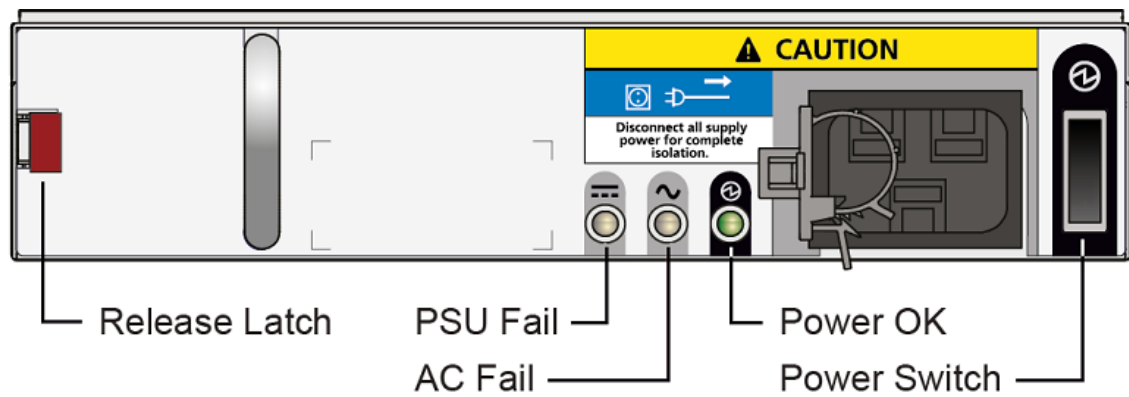

2200W PSU LED Status

PSU Fail (Amber)	AC Fail (Amber)	Power OK (Green)	Status
Off	Off	Off	No AC power to either PSU
On	On	Off	PSU present but not supplying power
Off	Off	On	Mains AC present, switch on. This PSU is providing power
Off	Off	Flashing	AC power preset, PSU in standby mode (other PSU is providing power)
Flashing	Flashing	Off	PSU firmware download in progress

2200W PSU LED Status

PSU Fail (Amber)	AC Fail (Amber)	Power OK (Green)	Status
On	On	Off	PSU alert state (usually due to reaching critical temperature)
Off	On	Off	Mains AC to this PSU is missing (This PSU is on standby, other PSU is OK)
On	On	On	GEM software has lost communication with PSU
On	---	Off	PSU has failed

5U Chassis Fans

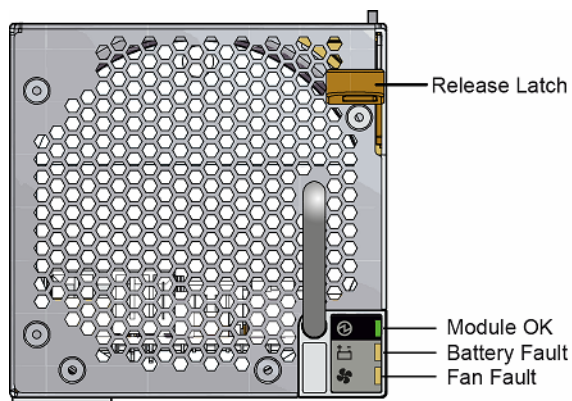

5U Chassis Fan LED Status

Fan OK (Green)	Battery fault (Amber)	Fan fault (Amber)	Status
---	---	Off	Fan OK
---	---	On	Communication lost with fan module controller
---	---	On	Reported fan speed is out of tolerance
On	Off	---	Fan and battery OK
Flashing	Off	---	Battery charging
Off	On	---	Battery fault
On	---	Off	PSU has failed



Leave failed power supply or cooling modules in place until you have a replacement so you maintain the proper airflow. Obtain a replacement as soon as possible.

2 Connecting the Equipment

This chapter explains how to rack mount and connect the system hardware.

Rack Mounting Guidelines and Requirements

Avid recommends installing the Avid NEXIS hardware in a rack, using the following guidelines:

- If installed in a closed or multi-unit rack assembly, the operating ambient temperature of the rack environment might be greater than room ambient. Make sure the rack environment is compatible with the maximum ambient temperature (T_{ma}) specified by the manufacturer.
- Avoid uneven mechanical loading.
- Make sure your rack enclosure is stable enough to prevent tipping over if using extending sliding rails.
- Follow the equipment nameplate ratings to avoid overloading the circuits.
- Maintain reliable grounding of rack-mounted equipment, especially regarding supply connections other than direct connections to the branch circuit (for example, power strips).
- Avid airflow is from the front of the enclosure to the rear. Make sure nothing blocks airflow to the front panel surface and the rear.
- For normal operation, maintain approximately 2 feet (0.6 meters) of open space in front of and behind the rack. This allows free access to the components in the rack for operating changes or adjustments. For service, maintain approximately 3 feet (1 meter) of open space in front of the rack and 2 feet (0.6 meters) of open space behind the rack. This allows for the removal of any component that needs to be replaced.
- Allow at least 0.5 in (1.3 cm) clearance on top of the enclosure for cover removal.



To ensure the stability of the rack enclosure, install the heaviest equipment in the lower sections of the rack enclosure. Install lighter equipment in the middle and upper sections.



For information about power specification and dimensions see “[Specifications and Notices](#)” on [page 63](#).

Mounting the Engine or System Director Appliance

The Avid NEXIS Engines are designed for 19-inch (483-mm) rack configurations and need rack units corresponding to the chassis size. See “[Avid NEXIS Platforms](#)” on [page 1](#).

The rack mount kit can accommodate racks with round, square, or threaded holes, sometimes called broadcast racks. Installation instructions are included on a decal located on the side of one of the bracket rails.



Do not lift the Engine by the handles on the power supply units, cooling modules or Controller – they are not designed to support the weight of the entire system.



Avid recommends that two people lift the Engine, especially when installing in upper rack units.

To mount a 2U or 4U chassis in the rack:

1. Install the mounting rails using the instructions on the attached label.
2. If you have a redundant Controller, insert it fully into the chassis before installing the chassis in the rack.
3. Slide the chassis onto the mounting rails and secure to the rack using the two supplied screws.
4. Insert the Media Pack drives into the empty drive slots (see [“Installing the Media Packs \(2U and 4U Chassis\)”](#) on page 31).
5. Remove the plastic end cap covers from the front of the chassis. (These cover the screws that secure the chassis to the rack in the absence of a bezel.)
6. Attach the bezel to the front of the chassis.

To mount a 5U chassis in the rack:

1. (Option) If using racks with threaded holes, unscrew and remove the five round pegs on each end of the bracket rail.

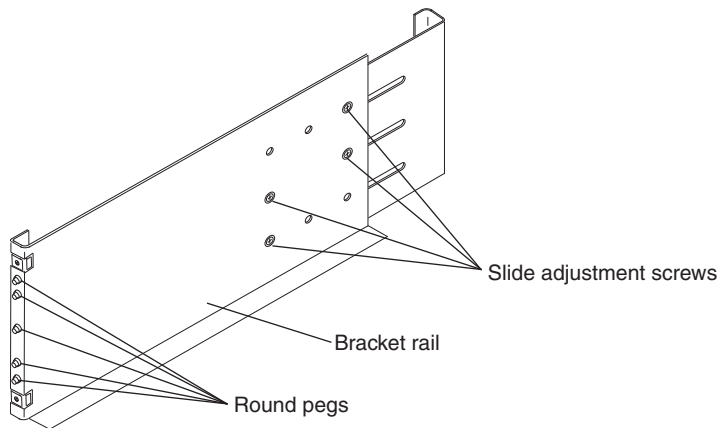

2. Loosen the four slide adjustment screws so to adjust the bracket rail to the depth of your rack. The adjustment screws are highlighted in a colored circle around the screw.
3. Position the bracket rail between your rack mount rails and adjust the length of the bracket so that it meets the inside of both the front and rear rails as shown in the following figure.

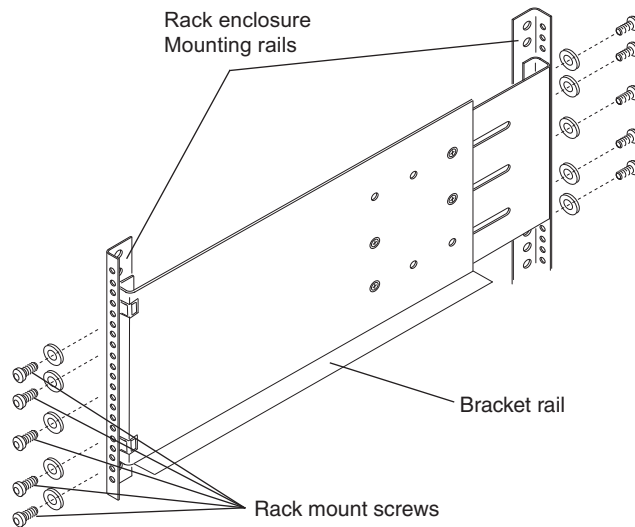

4. Secure the bracket rail to the front and rear mounting rails using either the screws that come with the rack mount kit of your rack screws (five screws in the front and the rear).



Leave the top holes on the front of the rail empty so you can use those holes to secure the Engine to keep it from sliding forward once racked.

5. Tighten the four slide adjustment screws.
6. Repeat steps 1 through 5 to install the other bracket rail on the opposite side of the rack.
7. Make sure that the media drives are not installed in the Engine.
8. With an assistant, lift the Engine and place the rear of the Engine onto the brackets as shown in the following figure.

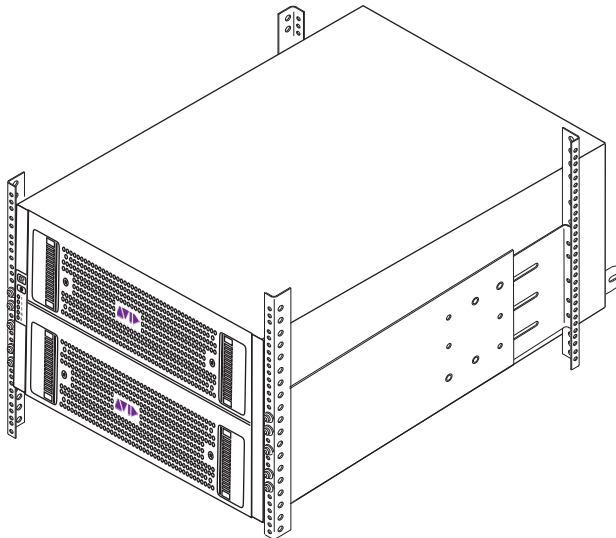

9. Position the bracket extender on the outside of the rear mounting rail so that the sliding nut in the bracket extender inserts into the rack mounting tab on the Engine. Using the short screws included in the rack mount kit, secure the bracket extender to the rack mounting tab on the Engine as shown in the following figure.

The rack mount kit provides two sets of bracket extenders: a long pair and short pair. Use the pair of bracket extenders that are most appropriate for your rack. For shallower racks use the longer bracket extenders.

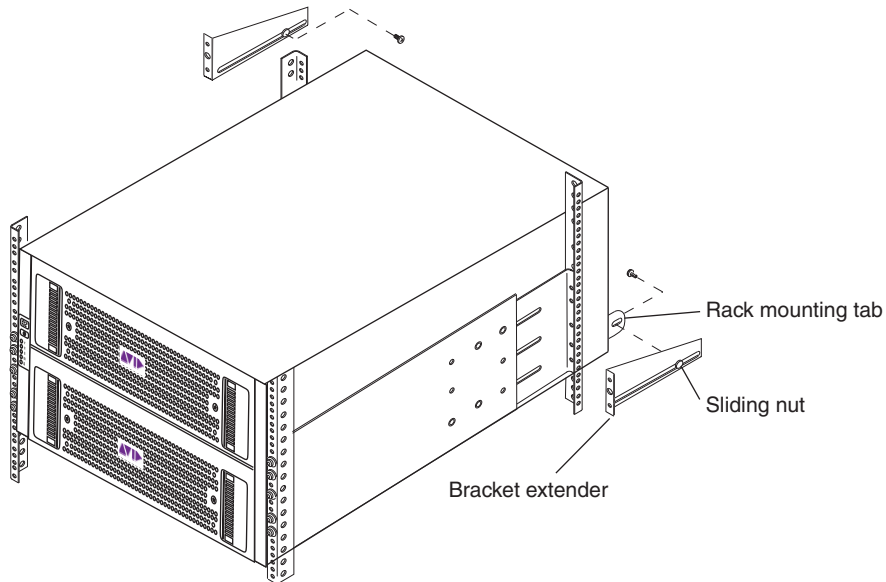

- Using the screws from the rack mount kit, secure the Engine to the front of the rack through top and bottom holes of the plastic end caps as shown in the following figure.

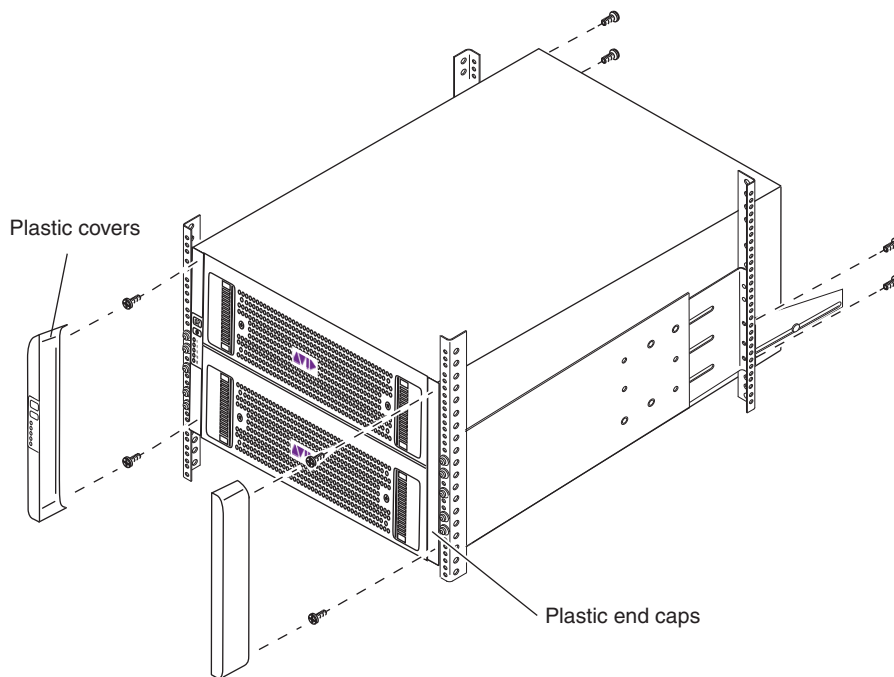

- Using the screws from the rack mount kit or screws you supply, secure the rear stabilizer brackets to the rear rack mount rails through top and bottom holes in the extender bracket as shown in the preceding figure.
- Snap the left and right plastic covers over the plastic end caps on the front Engine as shown in the preceding figure.

Installing the Media Packs (2U and 4U Chassis)

A Media Pack consists of ten drives. See “[Media Pack and System Drives](#)” on page 19 for more information. You can optionally install up to two spare media drives in 4U Engines.

To install the Media Pack (and optional spare) drives:

1. Make sure the anti-tamper lock is not engaged (see “[Media Pack and System Drives](#)” on page 19). The red lock indicator is visible if the lock is engaged. Unlock the drive using a screwdriver with a Torx T20 bit by rotating the lock counterclockwise until the lock indicator is completely hidden.
2. Insert the drive into the slot, with the lock mechanism facing left.
3. Push the drive in until the release latch starts to pull inward.
4. Push the release latch in you hear it click shut.
5. Lock the drive with the Torx T20 bit; make sure the red lock icon is fully visible in the viewing window.

Installing Media Pack Drives (5U Chassis)

A 5U chassis comes with at least four Media Packs, and supports between four (minimum) and eight Media Packs, and up to two spare drives. The system drives are preinstalled in the Engine, in slots 28 (top drawer) and 70 (bottom drawer).

For correct airflow, the chassis must contain at least four Media Packs (divided between the two drawers) and two system drives.

If starting with fewer than eight Media Packs, populate the front rows of both drawers first, then the middle rows. As you purchase and install more Media Packs and spares, fill the slots in the remaining rows (there is no need to move the spare drives when inserting additional media drives).

Insert spare drives in the slots immediately after the last Media Pack drive.

To install the Media Pack drives:

1. Open the top drawer.
2. Install 20 of the Media Pack drives into the first several rows of slots. Push each drive downwards and hold it down while sliding the drive carrier plate in the direction shown in the following figure. This locks the drive in place.

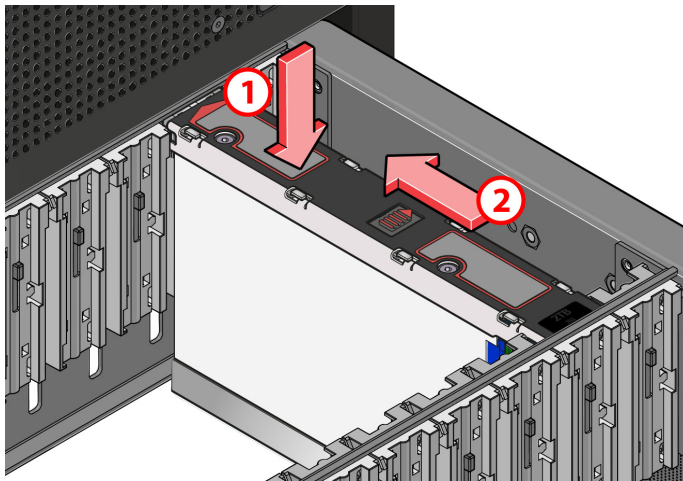

Make sure the drive is securely locked into place before closing the drawer. Unlocked drives can open due to chassis vibration and lift up enough to prevent the drawer from opening. Forcing the drawer open will damage the drive and the chassis.

3. Close and lock the drawer.
4. Open the bottom drawer.
5. Install the remaining 20 Media Pack drives into the first several rows of slots. Again, make sure all drives are locked.
6. Close and lock the drawer.

Connecting Power to Equipment

Two 10A power cables (North America standard) are shipped with all Avid NEXIS | E2, Avid NEXIS | E2 SSD, Avid NEXIS | E4, Avid NEXIS | PRO, and System Director Appliance systems. You might need to obtain power cords from your local reseller or support depot suitable for your locale.

The Avid NEXIS | E5 or Avid NEXIS | E5 NL Engine comes with two C19 to C20 power cables in the shipping box. The C19 end is a female connector which plugs into the power supply on the Engine. The C20 end is a male connector, which plugs into a Power Distribution Unit (PDU) with C19 style connectors.

For information about the APC® Basic Rack PDU with C19 208-240V outputs and a twist lock NEMA LP6-30 input), see: http://www.apc.com/products/resource/include/techspec_index.cfm?base_sku=AP9570

Avid does not recommend any specific vendor or model of PDU. A PDU is a rack mount ready, high current power strip that can offer a variety of plug types. Purchase a model that suits the needs of the equipment in your rack.

For the Avid NEXIS | E5 or Avid NEXIS | E5 NL, connect each power supply in the Engine to a different 30-amp circuit. This allows the system to continue running if one circuit fails.

Plug the power cords into the power supplies on the back of the Engine (and the back of the System Director Appliance, if using one) and then plug the other ends into power outlets on separate circuits. If they are not already in the ON position, turn on the switches on the power supplies.



The system takes a few minutes to perform some internal processes before the fans start running.

Connecting the Hardware to a Switch

Basic Switch Connections

See the *Avid NEXIS Network and Switch Guide* for the currently supported switches, cables, and transceivers for use with an Avid NEXIS Engine or the System Director Appliance.



You must connect each Engine and, if applicable, the System Director Appliance, to supported switches, which must be networked together. You cannot set up the Engine or the System Director Appliance until they are connected to suitable switches in your network.

Connect the Engine or System Director Appliance to a suitable switch, as follows:

Use a 10GbE Switch with:

Use a 40GbE Switch with:

Avid NEXIS | PRO, Avid NEXIS | E2, Avid NEXIS | E4, System Director Appliance, Avid NEXIS | E5 NL

Avid NEXIS | E2 SSD, Avid NEXIS | E5

The following figures show sample connections between an Avid NEXIS Engine and a switch.



All the Avid NEXIS | E-Series Controllers and some models of Avid NEXIS | PRO use the same port to connect to a switch. The following figures are examples only; your configuration may vary depending on how many Controllers are installed, how many switches you are connecting to, and whether LACP is enabled.

10 Gb Network Connection from Switch to Avid NEXIS | PRO Controller (Purple Fascia)

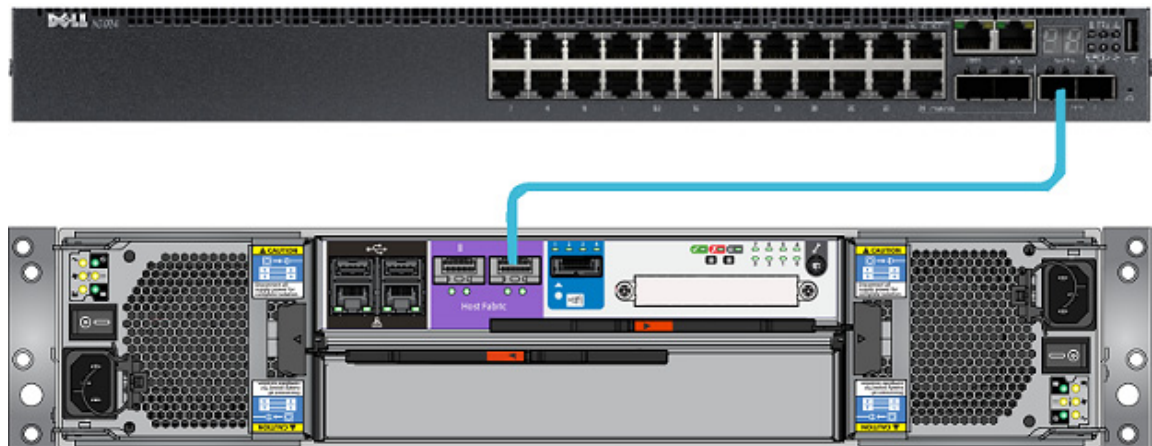

10 Gb Network Connection from Dell N3024 Switch to Avid NEXIS E-Series Controller (E2 Shown)

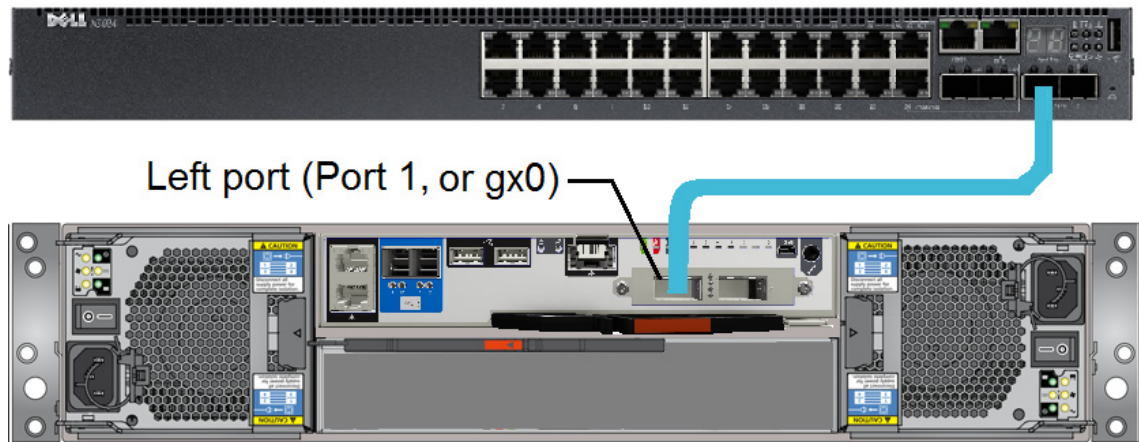

40 Gb Network Connections from Cisco Nexus 9372PX Switch to Avid NEXIS | E5

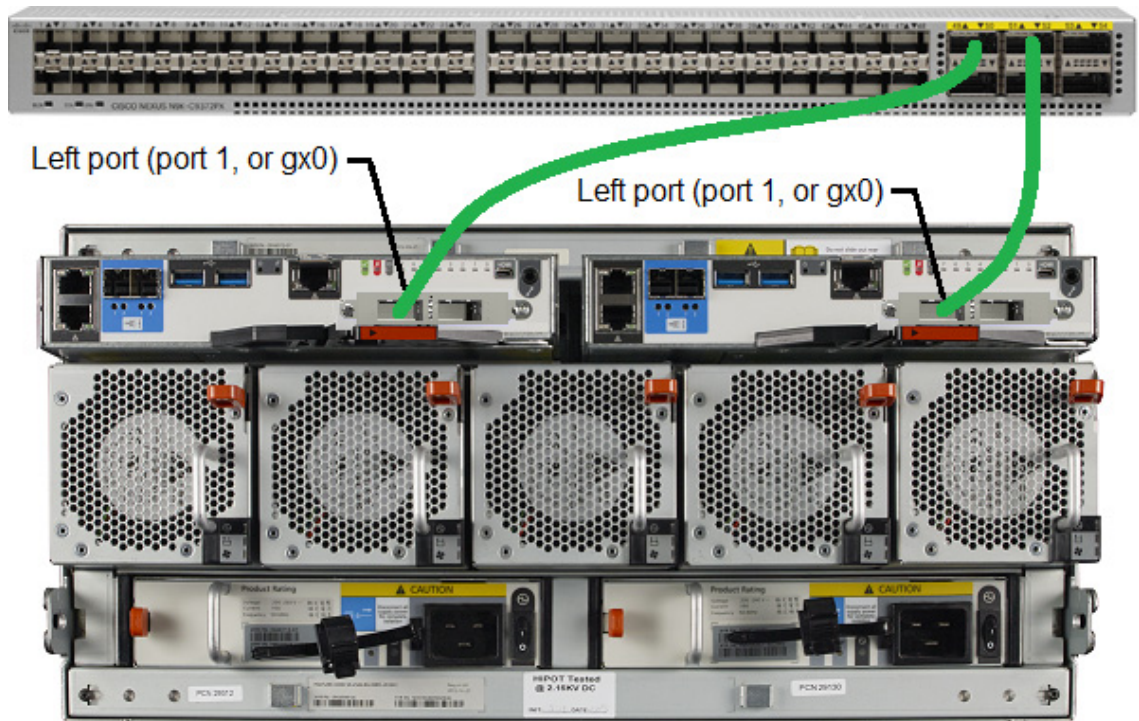

 *Avid NEXIS | E5 NL connects to a 10GbE switch. Use the supplied QSFP to SFP+ adapter, shown below.*

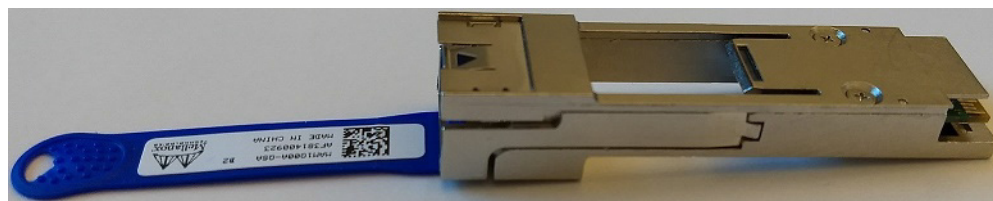

Enabling Link Aggregation

In Avid NEXIS v7.0 and higher, you can enable link aggregation (also called redundant networking, NIC teaming, link bundling, or port trunking) on the Controllers in an Engine or System Director Appliance. (Link aggregation is not supported on Avid NEXIS | PRO.)

LACP is supported in systems with one or two Controllers, but if two Controllers are present, it is enabled on both. The Ethernet ports on all installed Controllers must be connected to one or more supported switches.

The Avid NEXIS implementation follows the Link Aggregation Control Protocol (LACP) standard.

See the *Avid NEXIS Administration Guide* for information on configuring LACP on the switch, connecting the cables, and enabling LACP on the Avid NEXIS system.

The following figures provide examples of how to connect cables between the network ports on the Controllers and an LACP-enabled switch.

Dual Network Connections from 10Gb Switch to Avid NEXIS | E2 for LACP

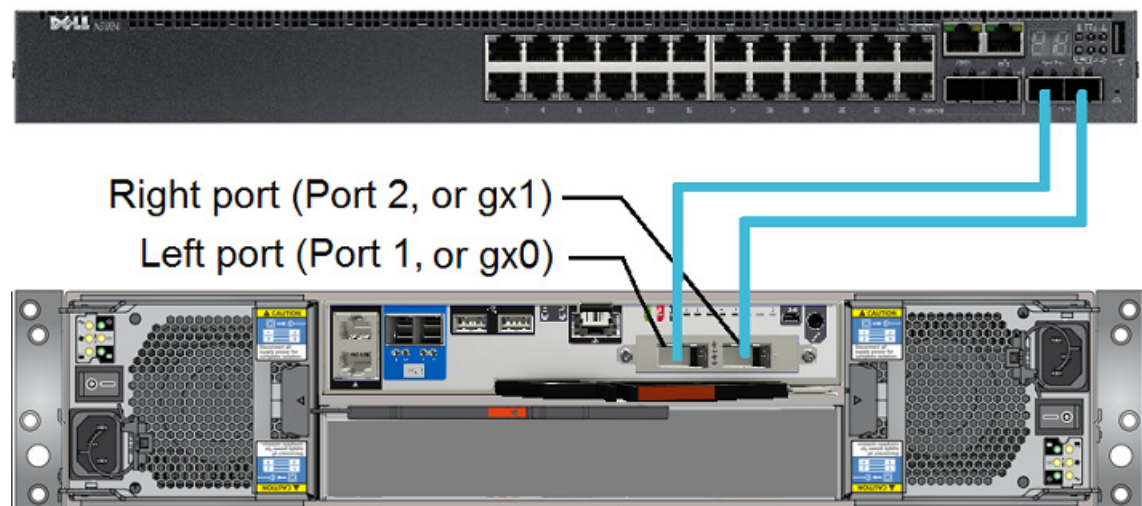

Dual Network Connections from 40Gb Switch to Avid NEXIS | E5 for LACP

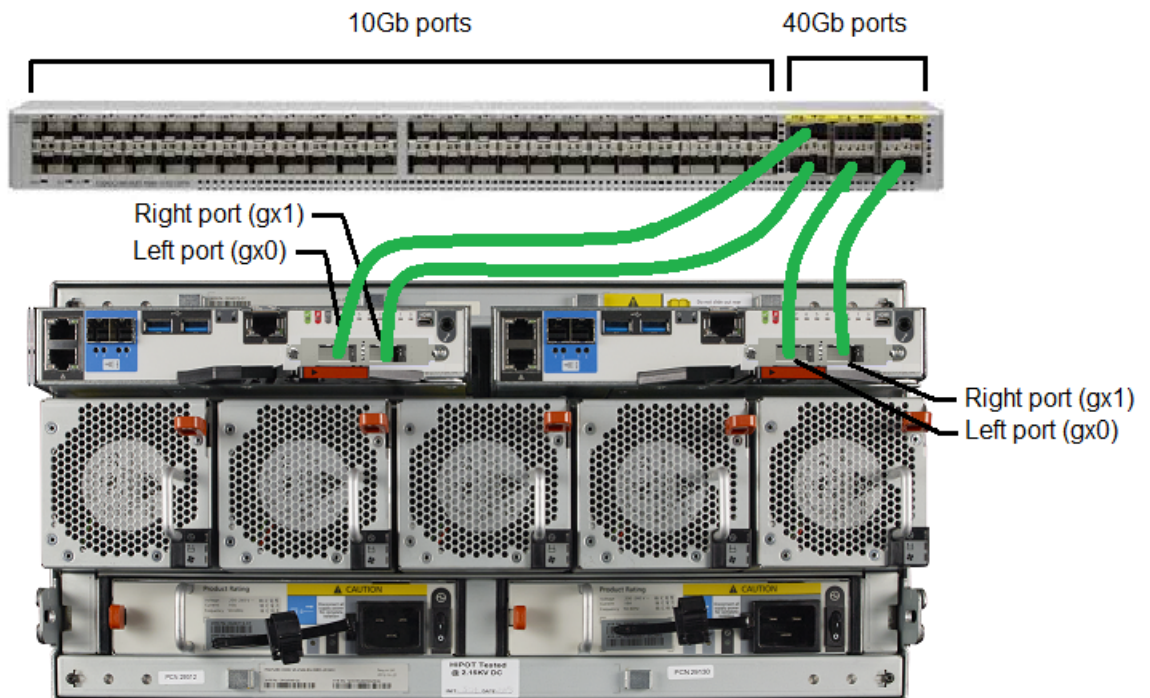

3 Software Installation and System Setup

This chapter describes how to install or upgrade and configure the Avid software on a new Avid NEXIS system.

If you have questions, call your Avid representative or your local ACSR.



Before you start the procedures in this chapter, familiarize yourself with the information in [Avid NEXIS System Overview](#), and make sure the Avid NEXIS Engine is connected to a switch, which is in turn connected to your network. See “[Connecting the Hardware to a Switch](#)” on [page 33](#) and the *Avid Network and Switch Guide*.

System Setup Information

To complete the initial software installation and system setup, you will need the following information.

Required Information	Notes
Storage System Name—Identifies the Avid NEXIS system to clients and to all the Engines, and the System Director Appliance if applicable, that belong to the same Avid NEXIS system. See “ Understanding the Shared Name Space ” on page 38 .	The Storage System Name must follow RFC 952 and RFC 1123 guidelines for host names. Avid NEXIS supports names including <i>only the following</i> : up to 31 English alphanumeric characters (a-z and A-Z, and 0-9), plus a dash/hyphen character (-). The name must start with a letter or number, and cannot end with a dash.
Engine Name—Name for the Engine or System Director Appliance, if applicable. See “ Understanding the Shared Name Space ” on page 38 .	Names can be up to 25 English alphanumeric characters long, can contain a dash or hyphen (-), must start with a letter, and cannot end with a dash.
Controller IP addresses	In a multi-Engine configuration, you will need a separate IP address for each Controller in each Engine, all of which must be on the same subnet.
Netmask and Gateway IP address	Must be the same for all the Controllers in all Engines in a multi-Engine configuration

The following information is optional, if your environment supports its use.

Optional Information	Notes
DNS domain, server list and search list	If your environment uses DNS, you can enter that information to allow you to use either the System Director name or the IP address to connect to the Avid NEXIS system. For more information, see “ What is DNS? ” on page 39 .

Optional Information	Notes
NTP server IP addresses	<p>You can configure up to two. These must be entered on all Engines in a multi-Engine configuration. For more information, see “What is NTP?” on page 39.</p> <p>Alternatively, enter the local time and time zone information.</p>

Understanding the Shared Name Space

The Avid NEXIS shared storage system uses several names to identify its physical and virtual components.

Storage System Name

The Storage System Name represents all the physical Engines, and the System Director Appliance if applicable, operating as one shared storage group. This name is displayed in the bottom of the Management Console to distinguish one collective Avid NEXIS group from another. Clients see and connect to the Storage System name through the Client Manager UI. You enter the Storage System Name in the Remote Host Settings dialog box in the Client Manager if the Avid NEXIS system is not in the same subnet as the client system (use the System Director IP address if your environment does not use a DNS server; see [System Director Name and IP Address](#)).

Engine and Controller Names

Each Engine, and the System Director Appliance if applicable, has an Engine name. The Engine name is used to generate the hostnames of the Controllers in that chassis. This helps associate a particular Controller with the physical chassis it resides in.

System Director Name and IP Address

The shared storage system has one System Director, which runs either on an Engine (if no System Director Appliance is present) or on the System Director Appliance. Specifically, the System Director runs on one of the Controllers in the Engine or System Director Appliance.

The System Director is a service that can switch over to the redundant Controller in an Engine or System Director Appliance, if two Controllers are present. The System Director name, therefore, can change based on where it is running at the time:

- In a multi-Engine configuration that does not include a System Director Appliance, the System Director runs on the first Controller in the first configured Engine. Therefore, that Controller name is initially also the System Director name.
- In a configuration with a System Director Appliance, the first Controller in the System Director Appliance runs the System Director, and its name initially becomes the System Director name.

Because the System Director service can migrate between the Controllers, the System Director uses an IP address different from the IP addresses assigned to the Controllers. This functions as a virtual IP address, and allows you to connect to the System Director any time, without needing to know the IP address or hostname of the Controller currently serving the System Director process.

What is DNS?

DNS, or Domain Name System, is a distributed naming system that lets you use human-readable and -memorable names for computers in your environment. The Internet uses the same principle; for example, to go to Avid's website, you enter `www.avid.com` into a browser. If the Internet did not have the ability to resolve that name to an IP address, you would have to remember and enter the IP address for Avid's website: namely, `198.37.38.15`.

Because most people find it easier to remember a name than a number, with a DNS service in your environment, you can use the name you assign to your Avid NEXIS system (for example, `MyAvidStorage`) instead of the IP address. Then you can enter the name into a browser to open the Management Console and log in. Using DNS is not required; however, the Avid NEXIS supports its use.

What is NTP?

NTP, or Network Time Protocol, is a means of synchronizing the system clocks for all the computers in your environment. This can be important in cases where network-wide operations must happen at the same time, or for logging accuracy, or simply to eliminate potential human error when setting system times manually. Using NTP is not required; however the Avid NEXIS supports its use.

Installing and Setting Up the System

The process of installing and setting up the Avid NEXIS Engine and System Director Appliance, if applicable, consists of the following overall steps:

1. Rack mount the hardware, connect the hardware to power and to a switch, and turn on the power supplies. See [“Connecting the Equipment” on page 27](#).

When you turn on the power supplies, the hardware begins its internal startup processes; it can take several minutes before the system becomes available to log in. The LEDs on the Engine (or System Director Appliance) and power supplies light up. After a few minutes, the power supply fans run at their maximum RPM for the next couple minutes, then slow down to normal RPM.

While the system is performing its startup routines, complete steps 2 and 3.

2. Register the system and download the software onto a computer you can physically connect to the Avid NEXIS hardware. See [“Registering the System and Downloading the Avid NEXIS Software” on page 40](#).
3. For each piece of hardware, connect the computer to the hardware and set its IP address to be compatible with the hardware. See [“Configuring the Computer's IP Address” on page 40](#).
4. Log into the hardware and run the setup wizard, which lets you install the software and configure the system, starting with the System Director Appliance, if applicable. See [“Installing the Software and Setting up the Avid NEXIS System” on page 43](#).
5. Log into the Management Console and create the file system. See the *Avid NEXIS Administration Guide*.
6. Bind the Media Packs to the Avid NEXIS file system. See the *Avid NEXIS Administration Guide*.

Registering the System and Downloading the Avid NEXIS Software

You must register your system before you can download the Avid NEXIS software, then connect a computer to the Avid NEXIS Engine (or System Director Appliance) to install the software and configure the system. Avid suggests downloading the software onto the same computer you will connect to the hardware.

To register the hardware and download the software:

1. Open a browser and go to www.avid.com/activationcard and register your Avid NEXIS system using the System ID card shipped with your system.
2. After you register, the software will be available in your Avid.com account. Download the Avid NEXIS software kit (a zip file) to a computer that you can physically connect to the Engine or System Director Appliance.
3. Unzip the software kit. You will see several files and folders. The file you will install on the Engine is named `AvidNEXISSetup_<version>.bin`.

Configuring the Computer's IP Address

To communicate with the Avid NEXIS hardware, the computer must use an IP address in the same subnet as the default IP address on the Controller (169.254.10.10). For this guide, we use the address 169.254.10.20.

This procedure assumes the computer is running a Windows operating system.

To configure the computer's IP address:

1. Connect a standard Ethernet cable between the computer and the Management port on the Controller of the first (or only) Engine you are setting up, or on the System Director Appliance, if applicable.

If two Controllers are installed:

- Connect to the Controller in slot 0 (top slot) for Avid NEXIS | E2, Avid NEXIS | E4, Avid NEXIS | PRO (20TB), and System Director Appliance
- Connect to the Controller in slot 1 (bottom slot) for Avid NEXIS | E2 SSD and Avid NEXIS | PRO (40TB)
- Connect to the Controller in slot 0 (left slot) for 5U chassis. Refer to the figure for E-Series Controller.



Use only the port indicated in the following figures. The other port is for connecting two Controllers (if supported).

Connecting to an E-Series Controller (SDA, E2, E4, E5, E5 NL, PRO 40 with Controller 10)

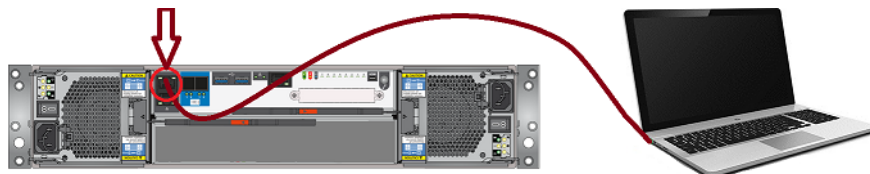

Management Interface Port — Connect to laptop.
Default IP Address: 169.254.10.10

Connecting to an Avid NEXIS | E2 SSD

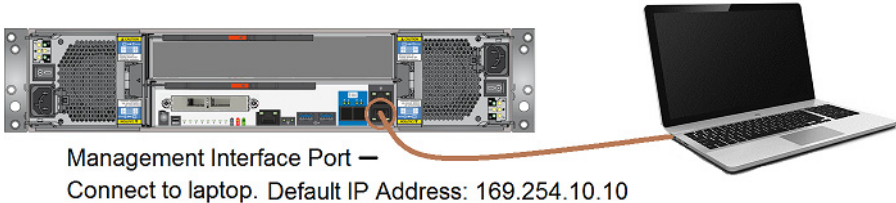

Connecting to an Avid NEXIS | PRO (20TB)

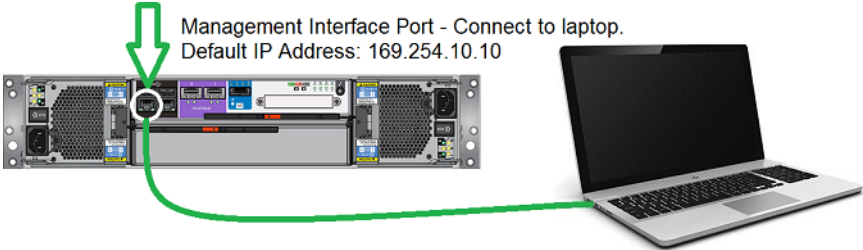

Connecting to an Avid NEXIS | PRO (40TB with Purple Fascia Controller)

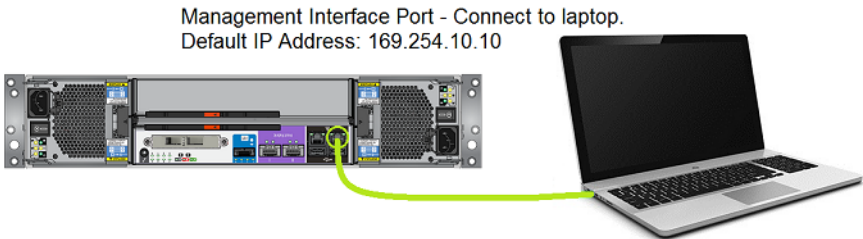

- 2. Open the Windows Control Panel Network and Sharing Center, then do the following:
 - a. Click Local Area Connection.

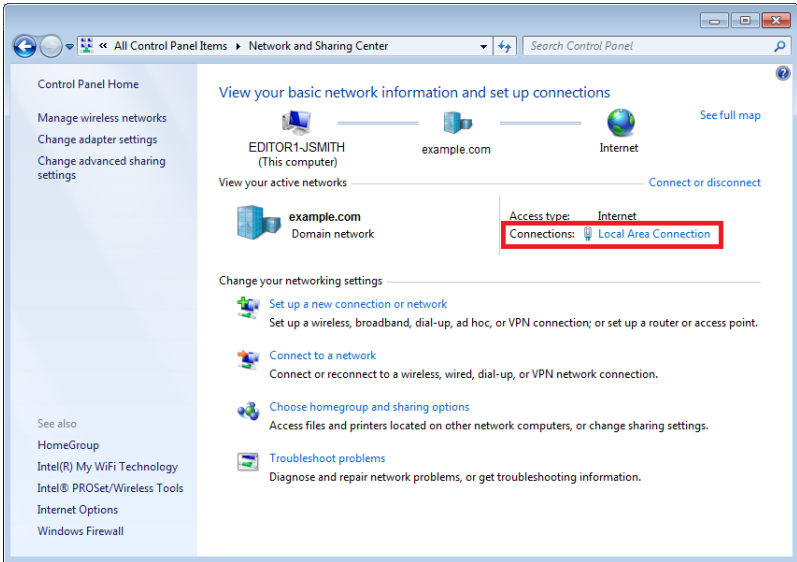

- b. Click Properties.

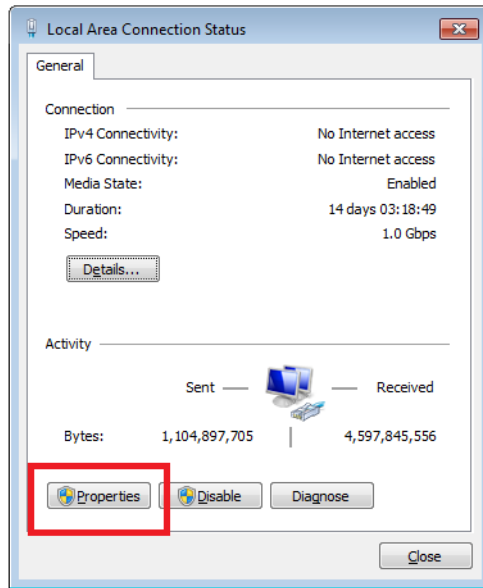

- c. On the Network tab, select Internet Protocol Version 4 (TCP/IPv4), then click Properties.

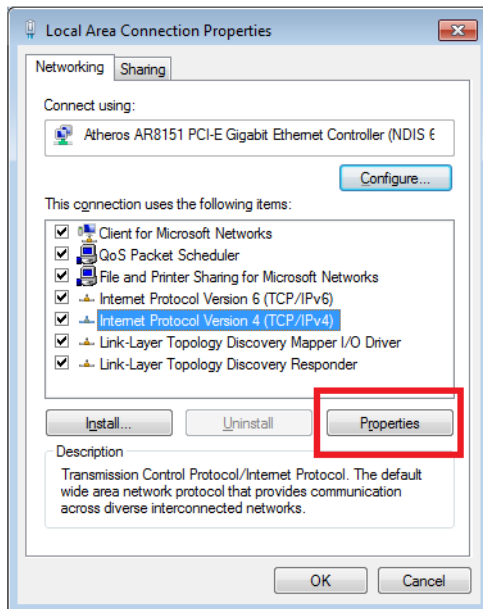

- d. Click **Use the following IP address:** and enter 169.254.10.20, with a subnet mask of 255.255.255.0, then click OK.



By default, the Controller IP address on every Avid NEXIS system is set to 169.254.10.10. You must set the IP address of the computer to 169.254.10.xx, where xx can be anything except 10. For this example, we chose 169.254.10.20.

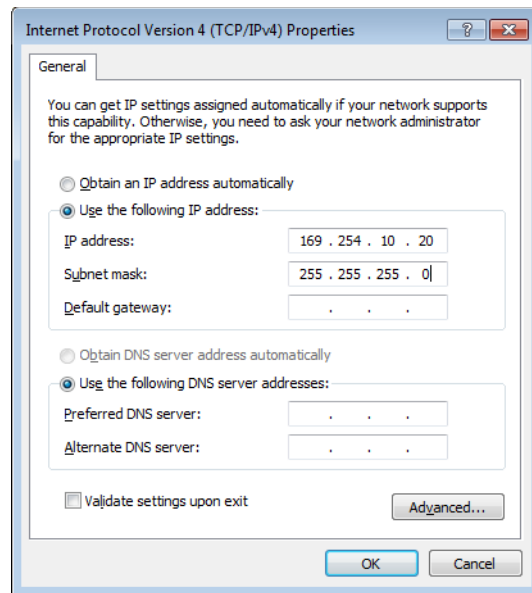

- e. Click Close to exit the Local area Network Properties dialog.
- f. Click Close to exit the Local area Network Status dialog.
- g. Close the Control Panel.

Installing the Software and Setting up the Avid NEXIS System

Through the setup wizard, you can configure multiple Engines, both with and without a System Director Appliance, identified by a single Storage System Name. You can also configure a redundant Controller in specific Avid NEXIS Engines or System Director Appliance, effective with Avid NEXIS v6.1 and higher.

See “Supported Configurations” on page 3 for configurations that can share the same name space and see “Types of Controllers” on page 13 for systems that support redundant controllers.



If you are deploying a System Director Appliance, configure it first, then configure the Engines.

This procedure covers all cases and indicates which of these steps applies to configuring multiple Engines.



Each Avid NEXIS Engine and the System Director Appliance, if applicable, must be connected to a switch for the software installation and configuration to work. If you have not yet connected the Avid NEXIS to a switch, see the *Avid Network and Switch Guide*.

To configure the system:

1. Open a browser and go to <https://169.254.10.10:5015>



*You might see a warning about the site’s security certificate. Double-check the IP address, and if it is correct, click **Continue to this website**.*

2. At the login screen, enter the default Agent password. (See “Controller (Agent) Password” on page 18.)

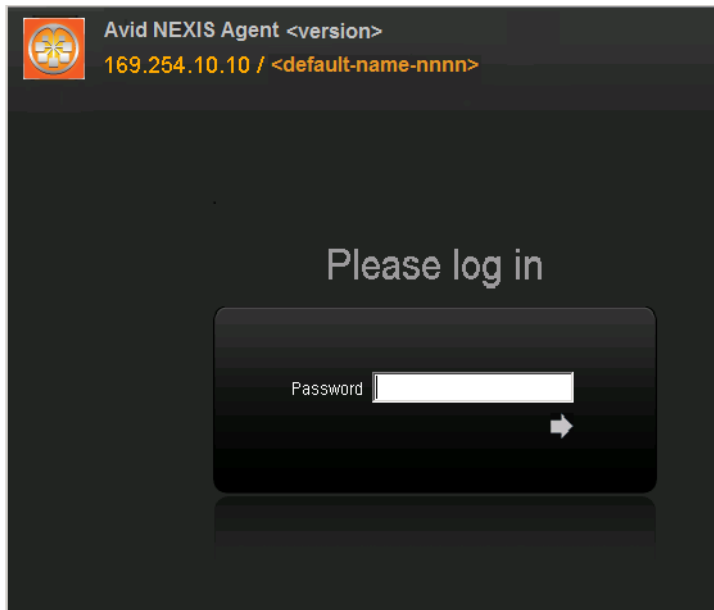

The wizard starts on the Install page.

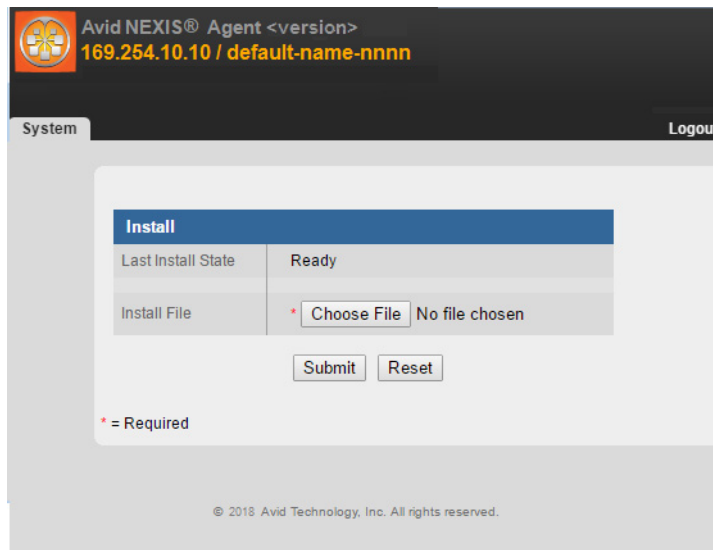

- a. Click **Choose File** to navigate to the location on the computer where you downloaded and extracted the Avid NEXIS software kit contents.
- b. Select the file named **AvidNEXISSetup_<version>.bin**.
- c. Click Submit.

The Engine installs the software and reboots, displaying messages about the installation progress and the time until the system will reboot.

3. When the system reboots, the Agent login screen is displayed again. Log back in to the Agent. The CONFIGURE screen is displayed.

Engine				
Storage System Name	* Enter name			
Enclosure ID	Enter v			
Engine Name	* Enter name			
Top Controller Hostname				
Bottom Controller Hostname				
System Director				
Run System Director	<input checked="" type="checkbox"/>			
IP Address	Enter IP Address			
Data Interfaces	Address	Netmask	Gateway	Speed
Top Controller	* Enter IP Address	* Enter Netmask	* Enter Gateway Address	10 Gbps Right
Bottom Controller	Enter IP Address	Enter Netmask	Enter Gateway Address	10 Gbps Right
Management Interfaces	Address	Netmask	Gateway	Speed
Top Controller	169.254.10.13	255.255.255.0	169.254.10.1	1 Gbps Left
Bottom Controller	169.254.10.14	255.255.255.0	169.254.10.1	1 Gbps Left
Domain Name Service (optional)				
DNS Domain	Enter DNS domain			
DNS Server List	Enter DNS server list			
DNS Search List	Enter DNS search list			
<input type="button" value="Next >"/> <input type="button" value="Reset"/>				

* = Required

4. In the Engine area do the following:

- a. **(Required)** Enter a Storage System Name. This is the name of the shared storage system containing one or more Avid NEXIS Engines, including the System Director Appliance, if applicable.
(In a multi-Engine system with a System Director Appliance, configure the System Director Appliance first and enter the same Storage System Name for it and each Engine in the shared-storage system.)
- b. (Optional) Enter a value for the Enclosure ID, which will be displayed on the Engine control panel; see [“2U Chassis Front Details”](#) on page 5. For example, in a four-Engine configuration, you could number them 01 through 04. If you do not enter a value, the default value (two dashes, or --) is displayed.
- c. **(Required)** Enter a name for the Engine. The Engine name is used to generate the hostnames for the Controllers, which appear in the fields below for Top and Bottom Controllers (in 2U and 4U chassis and System Director Appliance) or Left and Right Controllers (in 5U chassis).

5. In the System Director area, do the following:

- a. **(Required)** If you are not deploying a System Director Appliance and want this Engine to function as the System director, check the box next to Run System Director. (This checkbox is not present on a System Director Appliance, which is configured as the System Director automatically, or on 5U Engine, which cannot run as its own System Director. All 5U Engines require the use of a System Director Appliance.)
- b. **(Required)** Enter an IP address for the System Director. This must be different from the IP addresses you will assign to the individual Controllers. For more information, see [“System Director Name and IP Address”](#) on page 38.

6. **(Required)** In the Data Interfaces area, enter the IP address, netmask, and gateway you received from your IT administrator for the Controllers present (or those you plan to install) in the Engine or System Director Appliance.

This sets the address for the interface that communicates with the switch. If you have two Controllers, each must have a unique IP address, but the redundant Controller inherits the netmask and gateway from the first.

In a multi-Engine configuration, each Controller (in each Engine and the System Director Appliance, if applicable) requires a unique IP address but must use the same netmask and gateway.



In some systems only one controller is supported. If two controllers are detected, a radio button is displayed next to each controller. Select which controller you want to configure. See “Types of Controllers” on page 13 for information about which controller (slot) to select for your system.



Make a note of the System Director IP address you entered here; you will need it in a later step.

7. (Optional) In the Domain Name Service area, do the following:
- Enter the DNS domain name for your environment.
 - In the DNS Server list field, enter the IP addresses, separated by spaces, for the DNS servers in your environment.
 - In the DNS Search List field, you can enter alternate DNS names, separated by spaces, that are used in your environment. These will be used to help resolve the System Director name in a browser.
8. Click **Next**.

The Time setup screen is displayed. Setting the system time is required. If you plan to use an NTP server, Avid recommends also manually setting the system time. Otherwise, when the system reboots and the NTP server time is applied, a large time adjustment might be necessary, which can cause an error when creating the file system later.

- ▶ To use a Network Time server, check the box and enter IP addresses for up to two NTP servers in your environment.



In a multi-Engine configuration, enter NTP server or time information on all Engines.

- ▶ To manually set the date and time on the Engine, enter the current date, time, and select your time zone from the drop-down list.

If you configure one or more NTP servers and also manually set the date and time, the NTP servers take precedence.

9. Click **Next**.

The Agent password screen is displayed.

Avid recommends that you change the Agent password because the Agent password can also log into the Management Console. Changing the password also enables Avid support personnel to remotely connect to the system when necessary. The password can be up to 8 ASCII characters long. Enter the same password on all Engines and the System Director Appliance, if applicable, in the shared storage system.



Be very careful when entering the passwords. If you mistype the new password you will not be able to log in again.

10. Click **Finish**.

The system reboots again to complete the configuration.

11. To configure another Avid NEXIS Engine, disconnect the computer from the Management Port on the first Engine and connect it to the Management Port on the next Engine.

The computer is still set to the IP address you configured earlier, which is standard for all Avid NEXIS Engines you are configuring. You do not need to change the computer's IP address again.

12. Repeat this procedure until you have configured all the Engines that will be in the Avid NEXIS system.



Make sure all the Engines that will belong to the same Avid NEXIS system have the same Storage System Name.

13. When you have configured all the Engines, disconnect the computer from the Engine. You can optionally restore the computer's IP address to what it was originally. (Repeat the steps in [“Configuring the Computer's IP Address” on page 40](#), but at step 2d, instead of manually entering an IP address for the computer, click Obtain an IP address automatically.)

If you want to run the wizard again, open the Agent and click Wizard on the CONFIGURE tab. You can re-run the Wizard either to confirm your entries, or to make changes before you create the file system and bind Media Packs.

For information on those tasks, or for information on upgrading an Avid NEXIS shared-storage system, see the *Avid NEXIS Administration Guide*.

4 Adding and Replacing Hardware

The Avid NEXIS shared-storage system is designed to remain operational if a component fails. You can expand your system (add an Engine, add more Media Packs) to the existing file system in real time, as specified by your system configuration (see the *Avid NEXIS ReadMe* for configuration limits).

Do not add new hardware if there are any issues with the system. Correct all problems before adding new hardware or making changes to the system, and perform quick checks to verify that the system is in good working order.



Do not lift the chassis by the handles on the power supply units—they are not designed to support the weight.



Always have available a replacement or blank module before removing the old module. When you replace a module, do not leave a bay empty for more than 10 minutes.



Use a suitable anti-static wrist or ankle strap and observe all conventional ESD precautions when handling plug-in modules and components.

You can replace most hardware components without disrupting the system operation.

Collecting Logs for Customer Care

To help Avid evaluate returned components, collect any available system logs from the time the failure occurred, including any event or error messages, and send them to your Customer Care representative when ordering a replacement part.

To collect system logs:

1. In the Management Console, click Logs, then Event History.
2. Click Download.

A file named history.zip is created and saved to your default downloads directory.

3. Mention this file when ordering a replacement part. Your Customer Care representative can provide information on how to send that file to Avid.

Understanding Hardware Faults

LED colors are used consistently throughout the Engine and its components for indicating status:

- Green – good or positive indication
- Flashing green/amber – non-critical condition
- Amber – fault

Make sure that you have obtained a replacement before removing any faulty component.

**Observe all conventional ESD precautions when handling Engine modules and components.**

If the System Director Appliance and Engine are not communicating:

- Verify that the network cables from the Engine and the System Director are connected to the same switch.
- Check the indicators on the Controller (see [“System and Component Details” on page 5](#)).

Expanding a System

You can increase the capacity of an existing Avid NEXIS system by adding new Engines or by adding Media Packs to Engines that are not fully populated.

Adding an Engine to Your Infrastructure

You can add more Avid NEXIS Engines to your infrastructure to increase available space and allow for more flexible configurations. See [“Supported Configurations” on page 3](#) for information about the number of Engines and Media Packs supported in configurations with and without a System Director Appliance.

New Engines are configured to join the existing Avid NEXIS shared-storage system file system, which is designed for system expansion. For more information, see [“Avid NEXIS System Overview” on page 1](#).

**Do not create a new file system as part of adding new Engines to the system.**

Creating a new file system where one already exists is a permanently destructive operation, akin to reformatting the hard drive in a computer. All your Workspaces, containing all your media files, clips, project and bins, sound files, and all other media are permanently and irrecoverably destroyed. All system configuration, users and user groups, Storage Groups and Media Packs are deleted and must be re-created. There is no recovery.

After you add new Engines to the system, the Media Packs in those Engines can be added to an existing Storage Group or used to create a new Storage Group.

Before You Begin:

- ▶ Log in to the existing system and make a note of the following information:
 - Storage System Name
 - Avid NEXIS version
 - IP Address, netmask, and gateway assigned to the Controllers in all Engines in the shared storage system

To add Engines to an existing Avid NEXIS shared storage system:

1. Rack-mount the chassis and connect the power cables as described in [Chapter 2](#).
2. Connect one or more 10Gb network cables (depending on the number of Controllers) to the same subnet on the switch currently used by the existing Avid NEXIS system.
3. Turn on the new chassis.
4. Connect a laptop or local computer to the Management Port on the Controller *in the chassis you are adding* (the top or left Controller, if there are two) and configure the computer’s IP address to 169.254.10.20 and the subnet to 255.255.255.0.

5. Launch a browser and open the Agent on the new chassis: `https://169.254.10.10:5015`.
6. Download and install the same Avid NEXIS software version that is running on the existing shared storage system. As part of the software installation, the chassis reboots.
7. After the chassis restarts, reopen the Agent and configure the new system, with the following information:
 - a. Enter the **same** Storage System Name as the existing shared storage system it is joining.
 - b. Enter a name for the new chassis in the Engine Name field, and optionally enter an Enclosure ID.
 - c. Do not check the box to “Run as System Director.”
 - d. In the Data Interfaces section, enter an IP address for the Controller (or both Controllers, if applicable) **in the same subnet as the existing shared storage system**. If using redundant Controllers and LACP, check the Link Aggregation box.
 - e. Click Submit.

The new chassis reboots again.
8. When it has restarted, log in to the Management Console **for the shared storage system**. The new Engine appears in the Engines list with unbound Media Packs.
9. Bind the Media Pack (or Packs) to the **existing file system**. See the *Avid NEXIS Administration Guide* for more information.



DO NOT CREATE A NEW FILE SYSTEM ON THE EXISTING SHARED STORAGE SYSTEM.

10. Add the Media Pack (or Packs) to an existing Storage Group or you can create a new Storage Group. See the *Avid NEXIS Administration Guide* for more information.

If you add the Media Packs to an existing Storage Group, redistribution will begin.

Adding Media Packs to an Engine

Within the limits proscribed by your system configuration, you can add Media Packs to an existing, running system. By binding the Media Packs to the file system, they automatically become part of the Avid NEXIS shared-storage system, and are available to add to an existing Storage Group to increase its capacity, or to create a new Storage Group.

As a best practice, add Media Packs with the same capacity drives as the other Media Packs in your system. However, if you want to increase the total capacity of a Storage Group, you can add larger Media Packs and remove the smaller Media Packs. After you remove the last smaller-capacity Media Pack, the Storage Group expands to use the extra space. See the *Avid NEXIS Administration Guide* for more information.

If your system contains spare drives and you plan to add more drives of a different capacity, Avid recommends temporarily removing the spare drives before installing the new Media Pack drives. This prevents the system from assembling a Media Pack from mixed drive sizes, resulting in a Media Pack capacity based on the smallest of its drives.

Adding a Media Pack to an Engine (2U and 4U)

The Avid NEXIS | PRO, Avid NEXIS | E2, and Avid NEXIS | E2 SSD contain one Media Pack, installed at the factory. The Avid NEXIS | E4 Engine can contain up to two Media Packs of 10 drives each, and two optional spares. Two drive slots are reserved for the system drives. If your Avid NEXIS | E4 contains only one Media Pack, you can add another, inserting the drives in any order, in any available slots. The system combines any 10 unassigned drives into a Media Pack automatically.

To add a Media Pack to an Engine:

1. Remove the bezel; see [“Removing the Bezel” on page 53](#).
2. For each drive, do the following:
 - a. Remove the blank drive plate.
 - b. Fully open the drive latch.
 - c. Insert the media drive into the slot with the latch facing left.
 - d. Push the media drive in and push the latch inward until the drive locks in place.
 - e. Lock the media drive.
3. Reattach the bezel.

Adding a Media Pack to an Engine (5U)

Avid NEXIS | E5 and Avid NEXIS | E5 NL Engines have 84 drive slots, and can contain up to eight Media Packs of 10 drives each, and two spares. Two drive slots are preinstalled with the system drives. You can insert new Media Pack drives into any available slots; see [“Installing Media Pack Drives \(5U Chassis\)” on page 31](#) for recommendations on how to populate the drive drawers. The system combines any 10 unassigned drives into a Media Pack automatically.

To add a Media Pack to an Engine:

1. Open the appropriate drawer.
2. For each drive in the Media Pack, and each (optional) spare:
 - a. Remove the blank drive plate.
 - b. Lower the drive into the slot with the drive capacity label facing towards you.
 - c. Push the drive downwards and hold it down while sliding the drive carrier plate in the direction shown in the following figure. This locks the drive in place.



Make sure the drive is securely locked into place before closing the drawer. Unlocked drives can open due to chassis vibration and lift up enough to prevent the drawer from opening. Forcing the drawer open will damage the drive and the chassis.

3. When all the drives are installed, close and lock the drawer.

About Drive Failures

When a drive fails, the drive fault LED illuminates (see [“Media Pack and System Drives” on page 19](#)) and the Management Console and Agent display an error (see the *Avid NEXIS Administration Guide*).

If the failed drive is part of a Media Pack and a spare drive is available, the Media Pack status changes to `Drive rebuilding`. The Media Pack is also rebuilt when a drive is removed from the Engine, whether or not it has failed.

If a system drive fails, the Avid NEXIS Engine continues to operate, but you should replace the failed drive as soon as possible. If both system drives in the same Engine fail, the Engine stops operating because no metadata for writes can be recorded. If the Engine is part of a multi-Engine configuration, the whole shared storage system fails due to the loss of the Engine.

For non-mirrored Workspaces, when one or more drives in the same Media Pack fail, the impact depends on the number of Workspaces using storage on the Media Pack and the Media Pack Protection Mode on the Workspaces. For example, if three Workspaces are using space on the same Media Pack (in an Avid NEXIS | E2 Engine, for example), and the Workspaces use 0, one-, and two-drive protection respectively, drive failures have the following impact:

Workspace Protection Type (in Non-Mirrored Storage Group Only)	Number of Drives Failed	Result
0 (unprotected)	1	Workspace unusable
1	1	Workspace remains online
1	2	Workspace unusable
2	1	Workspace remains online
2	2	Workspace remains online
2	3	Workspace unusable

When the new drive is inserted, Avid NEXIS automatically rebuilds the Media Pack or formats and partitions the new system drive, as applicable.

Identifying the Slot Number for a Failing or Failed Drive

When a drive is failing or has failed, its status is displayed in several places:

- In the System Dashboard
- On the Engines page in the Storage menu. Click **Advanced**, then click the Disks tab. The slot number is shown in the disk details table.
- On the Media Packs pane in the Storage menu. Click **Advanced**, then click the Disks tab. The slot number is shown in the disk details table.

Replacing a Drive

Always replace a system drive or Media Pack drive with an appropriate drive from Avid of the same size as the failed drive. For more information, see [“Media Pack and System Drives” on page 19](#).



Do not use a system drive from another Engine or System Director Appliance as a replacement. The system drives operate as a pair, and contain metadata from the original system they belonged to. Using a system drive from another chassis, even if new and never deployed, will

cause problems because the system drives are initialized as a mirrored pair during the manufacturing process.

You can use a Media Pack drive from another Avid NEXIS Engine, but if it previously belonged to a Media Pack, you must clear its configuration before the new Engine can use it. See the *Avid NEXIS Administration Guide* for information about clearing a foreign disk error.

The replacement drive must be the same size as the failed drive, with the following exception: In a Media Pack, you can replace a smaller drive with a larger one (for example, use a 6TB HDD to replace a failed 2TB HDD). The Media Pack uses only 2TB of the space on the larger drive, however. You cannot replace a larger drive with a smaller one.

If you accidentally remove the wrong media drive while the Media Pack is reconstructing data for a failed drive, and client I/O is active, all client activity might stop after a brief delay as the system starts another reconstruction process. You can safely reinsert the drive within five minutes of removing it, and then remove the failed drive.

If a system drive fails, the system remains running as long as the other system drive is operating. If both system drives fail, the system shuts down.

After you replace a failed system drive, metadata reconstruction starts. The rebuild progress is displayed on the System Status Console in the Management Console. On an idle system, the rebuild typically completes within 20 minutes for a 400 GB drive. If the system is busy, the rebuild time can increase significantly, up to 40 hours if clients are performing heavy I/O (especially writes) during the entire rebuild process.

Removing the Bezel

On the 2U and 4U chassis, you must remove the bezel to access the media drives.

To remove the bezel:

- ▶ Insert your fingers into the rectangular openings on the front of the bezel and gently pull. The bezel is held in place by small plastic tabs that latch onto the face of the Engine. On the 2U chassis, there are also two small metal posts that snap into holes on the front of the chassis.
- ▶ To reattach the bezel, gently snap it onto the front of the chassis.

Removing a Drive (2U and 4U Chassis)

To remove a drive:

1. Remove the bezel; see [“Removing the Bezel” on page 53](#).
2. Identify the drive to be replaced by looking for the amber LED on the drive that indicates a fault; see [“Media Pack and System Drives” on page 19](#).
3. Make sure the anti-tamper locks are not engaged. The red arrows on the locks point inwards if the locks are disengaged. Unlock them if necessary by rotating them counterclockwise using a screwdriver with a Torx T20 bit.
4. Push the drive carrier latch in the direction of the white arrow.
5. Open the drive latch and pull the drive out of the slot.

Inserting a Drive (2U and 4U Chassis)

To insert a drive:

1. Fully open the drive latch.
2. Insert the drive into the slot with the latch facing left.
3. Push the drive in and push the latch inward until the drive locks in place.
4. Lock the drive.
5. Reattach the bezel.

Removing a Drive (5U Chassis)

To remove a drive:

1. Identify the drawer containing the failed drive; see [“5U Chassis Drive Drawer and Sideplane Status Panel”](#) on page 11.
2. Open the appropriate drive drawer and identify the failed drive by its LED. (See [“Media Pack and System Drives”](#) on page 19.)
3. Push the drive carrier latch in the direction shown in the following illustration to unlock the drive.

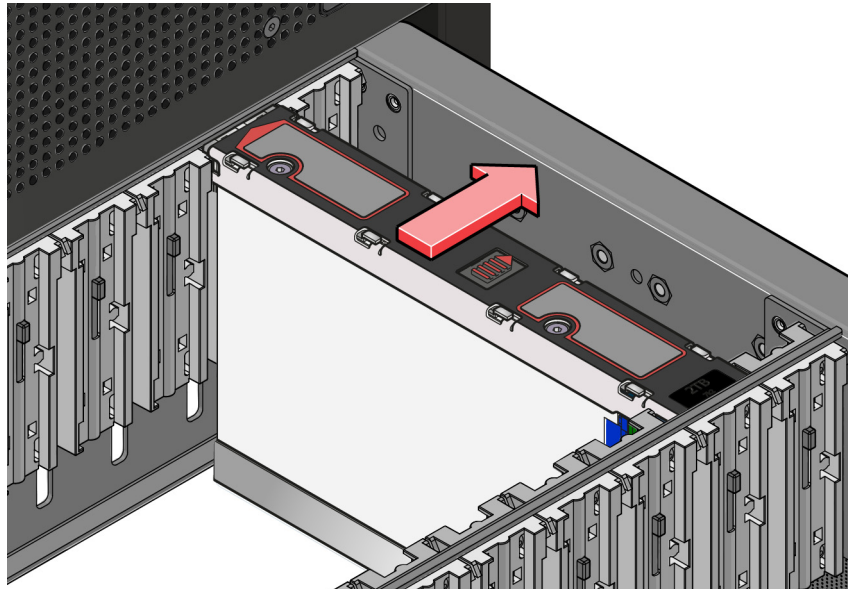

4. Pull the drive upwards and out of the drawer.



If you are not going to replace the drive immediately, close the drawer so that correct airflow and cooling are maintained in the Engine.

Inserting a Drive (5U Chassis)

To insert a drive:

1. Open the appropriate drawer.
2. Lower the drive into the slot with the drive capacity label facing towards you.

3. Push the drive downwards and hold it down while sliding the drive carrier plate in the direction shown in the following figure. This locks the drive in place.



Make sure the drive is securely locked into place before closing the drawer. Unlocked drives can open due to chassis vibration and lift up enough to prevent the drawer from opening. Forcing the drawer open will damage the drive and the chassis.

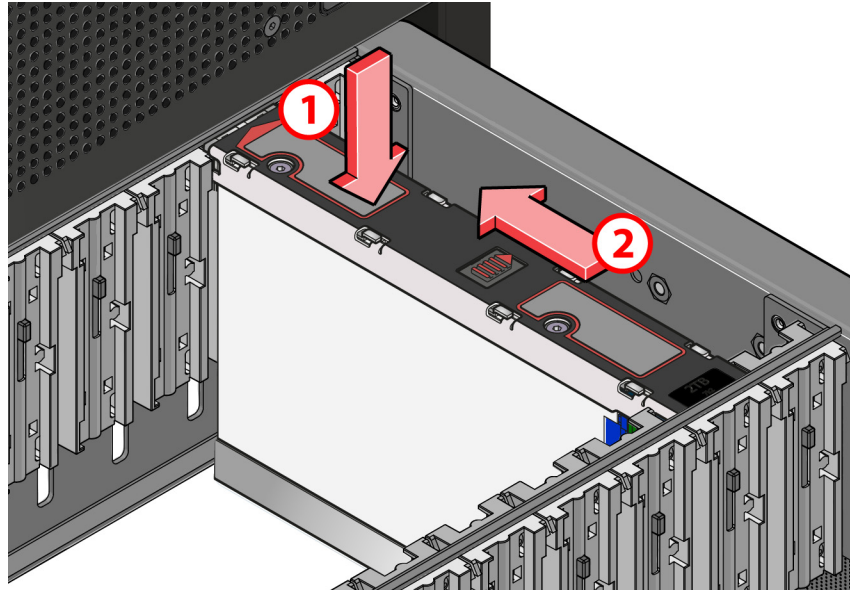

4. Close and lock the drawer.

Power Supply Failures

When you encounter a problem with the power supply, check for:

- Missing or damaged power cords
- Incorrect or ungrounded circuits
- Proper power is supplied to the Engine



When the Engine is turned on, all LEDs are lit for a short period to ensure that they are working. This does not indicate a fault unless the LEDs remain lit after a few seconds.



If a power supply's firmware is being programmed and the download fails, the power supply LEDs will flash.

See [“Power Supplies” on page 22](#) for more information.

Replacing a Power Supply (2U and 4U)

The power supplies in the 2U and 4U chassis include cooling fans as well as supplying power to the system. The power supplies are bi-directional; you can insert a power supply into either the left or right slot. When installed on the left side of the Engine, the plug is below the ON/OFF switch. When installed on the right side, the plug is above the ON/OFF switch.

To remove a power supply:

1. Open the strain relief and unplug the power cord.
2. Press the black release latch (see “Power Supplies” on page 22) towards the center of the module.
3. Open the silver latch, which disengages the power supply module from the Engine.

To insert a power supply:

1. Position the power supply so that the release latch and handle are closest to the Controller.
2. Slide the power supply into its slot and close the handle until the latch clicks in place.
3. Reconnect the power cord and secure the strain relief.

Replacing a Power Supply (5U)

In Avid NEXIS | E5 and Avid NEXIS | E5 NL, the power supplies are separate from the cooling modules. These systems are designed to continue working with only one of the two power supplies.



Make sure you have a replacement before removing a failed component to maintain proper airflow. When the Engine power is left on, insert the new power supply within two minutes after removing the defective power supply.

To remove a power supply:

1. Identify the power supply to be removed. If the module has failed, the fan fault LED will be lit amber.
2. Push the red release latch to the right and hold it (callout 1 in the following figure), then pull the module out by its handle (callout 2).

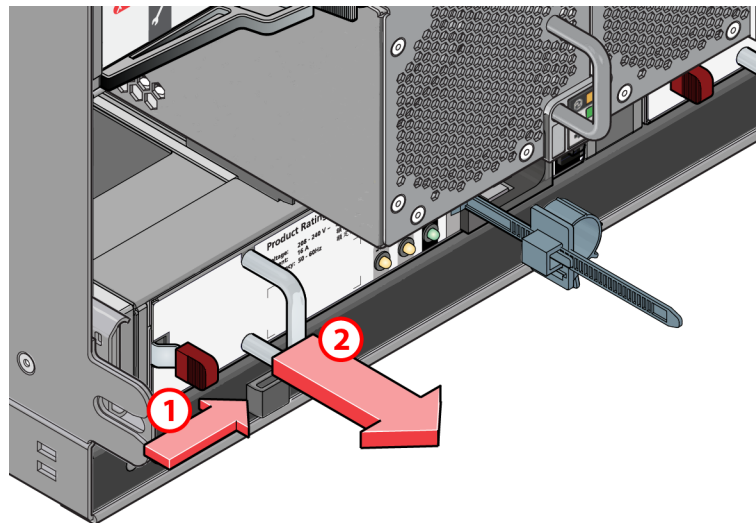
**To insert a power supply:**

1. Position the power supply so that the red release latch and handle are on the left-hand side.
2. Slide the power supply into its slot until the latch clicks in place. The Engine will automatically detect the new unit.

Replacing a Cooling Module (5U only)

In Avid NEXIS | E5 and Avid NEXIS | E5 NL, the cooling modules are separate from the power supply. These Engines are designed to continue working with at least two of the five cooling modules.



Make sure you have a replacement before removing a failed component to maintain proper airflow. When the Engine power is left on, insert the new cooling module within two minutes after removing the defective cooling module.

To remove a cooling module:

1. Identify the cooling module to be removed. If the module has failed, the fan fault LED will be lit amber (see “5U Chassis Rear View Details” on page 13).
2. Push down and hold the red release latch (callout 1 in the following figure) and pull the module out by its handle (callout 2).

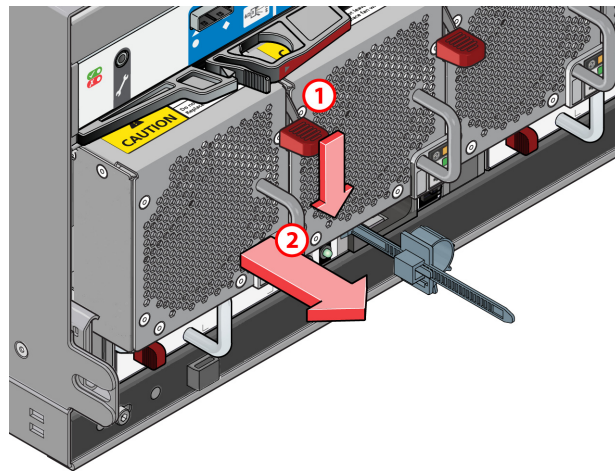

To insert a cooling module:

1. Position the cooling module so that the red release latch and handle are on the right-hand side.
2. Slide the cooling module into its slot until the latch clicks in place. The Engine will automatically detect and make use of the new unit.

Installing a Redundant Controller

You can order and install a redundant Controller for an Avid NEXIS Engine or the System Director Appliance. You can install the redundant Controller at any time, even if the Engine or System Director Appliance is already mounted in a rack and operating.



Both Controllers in an Engine must be the same type, with the same label. See “Types of Controllers” on page 13 for more information. In particular, make sure that both Controllers in an Engine have the same amount of memory. Installing Controllers with different memory capacities in the same Engine is not supported.

For highest availability, install a redundant Controller in all Engines and System Director Appliance, if applicable, in the entire shared storage system. However, you can install a redundant Controller in the System Director Appliance alone, to ensure the System Director fails over.



Avid NEXIS | PRO and Avid NEXIS | E2 SSD do not support redundant controllers.

Repeat this procedure for each Engine and the System Director Appliance if applicable.



Make sure to configure the second Controller before physically installing it into the Engine or SDA.

To install and use a redundant Controller:

1. Upgrade the Engine or the System Director Appliance to the current release if possible. See the *Avid NEXIS Administration Guide* for more information on upgrading your system. Avid NEXIS v6.1 is the minimum release to support redundant Controllers.
2. [On systems running v7.0 through 2018.4.n] Configure the second Controller as follows:
 - a. Open the Agent and click the CONFIGURE tab.
 - b. Enter the IP address for the redundant Controller.
 - c. Skip to step 4.
3. [On systems running 2018.5 and higher] Configure the second Controller as follows:
 - a. Open the Management Console and click System, then System Setup.
 - b. Click the blue Interfaces tab.
 - c. Enter the IP address for the redundant Controller.
 - d. (Optional) If you plan to enable link aggregation (LACP) on the Controller, see the *Avid NEXIS Administration Guide* before checking the box.
 - e. Click Save.
4. Remove the blank plate covering the empty Controller slot.
5. Install the redundant Controller as follows:
 - a. Open the release latch on the new Controller all the way.
 - b. Note the correct orientation of the Controller for the system you are adding it to:
 - In the 2U chassis the redundant Controller is installed upside down. See [“2U Chassis Rear Details” on page 6](#).
 - In the 4U chassis the redundant Controller is installed right side up, in the third slot from the top (leaving a one-slot gap between the first and redundant Controllers). See [“4U Chassis Rear Details” on page 8](#).
 - In the 5U chassis the redundant Controller is installed in the right-hand slot. See [“5U Chassis Rear View Details” on page 13](#).
 - c. Slide the replacement Controller into its slot until it will go no further.
 - d. Close the lever until it clicks in place.

The Controller engages with the connector on the midplane.
 - e. Check the Power/OK LED on the Controller to make sure it is lit; see [“Controllers for Avid NEXIS E-Series, SDA, and Avid NEXIS | PRO 40TB” on page 17](#) for more information.
6. Connect the two Controllers with the supplied cable between the ports indicated in the figures in [“Dual Controller Connection Diagrams” on page 59](#). The cable provides ongoing communication between the Controllers and must remain in place.

As soon as the Controllers are connected, the original Controller sends the necessary firmware and configuration data to the redundant Controller, bringing them into sync. This process can take up to 20 minutes. The system is fully usable during this time.

7. Log in to the management Console and verify that both Controllers are displayed and running the same version. For more information see the *Avid NEXIS Administration Guide*.

Dual Controller Connection Diagrams

Refer to the following figures when connecting two Controllers in an Engine or the SDA.

Connecting Two Controllers in a 2U Chassis



Connecting Two Controllers in a 4U Chassis

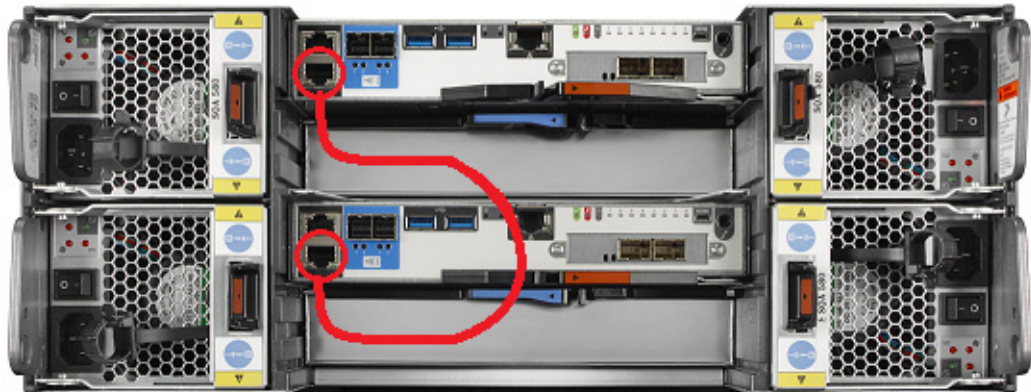

Connecting Two Controllers in a 5U Chassis

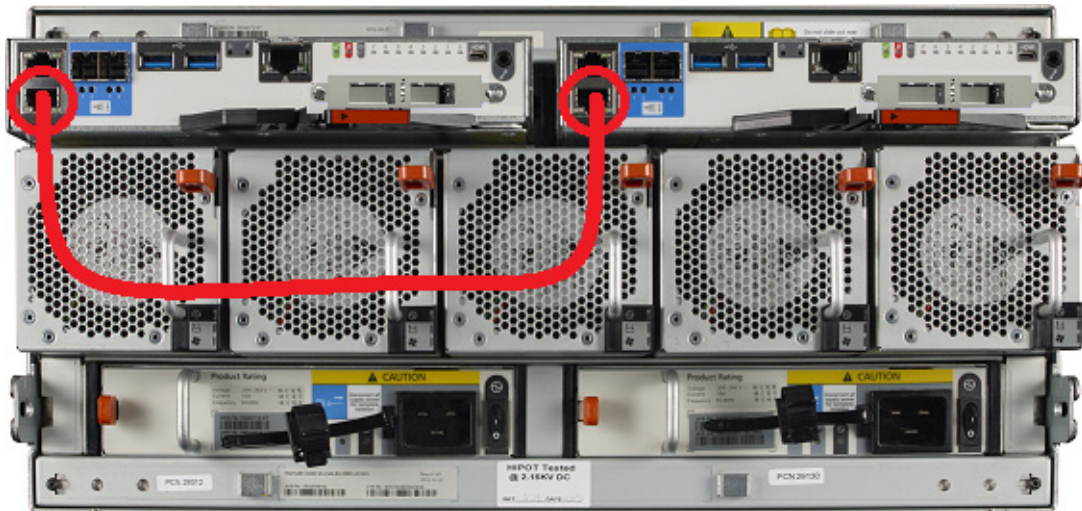

About Controller Failures

When a Controller fails, the fault LED will be lit red. If the Engine has two Controllers, services that were running on the failed Controller will move to the operational Controller. This process can take three to five (3-5) minutes on 2U and 4U Engines and the SDA, and 10 or more minutes on 5U Engines.

In an Engine with a single Controller, clients cannot access Workspaces until the Controller is replaced.



In an Avid NEXIS | E5 or Avid NEXIS | E5 NL with a single controller, insert the replacement controller in the same slot as the original factory-installed controller; by default, slot 0, or the slot on the left of the Engine looking at the rear.



Both Controllers in an Engine must be the same type, with the same label. See “Types of Controllers” on page 13 for more information. In particular, make sure that both Controllers in an Engine have the same amount of memory. Installing Controllers with different memory capacities in the same Engine is not supported.



Make sure you have a replacement before removing a failed component. When replacing a Controller while the system is running, insert the new Controller within two minutes of removing the defective Controller.

The new Controller can be a spare you already have on hand or a Controller purchased specifically because of a failure. No matter which replacement Controller you use, as soon as it is installed in the Engine the system automatically configures it with the current default Agent and Management Console passwords. Therefore, the manufacture date of the Controller (and its default password) does not affect the replacement process. For more information see “Controller (Agent) Password” on page 18.

Replacing a Controller

To replace a Controller:

1. Make note of the locations of all cables (between the two Controllers, if applicable, and to the switch) and disconnect them from the failed Controller.
2. Pinch the latch on the Controller and pull the handle toward you.

The controller disengages from the connector on the midplane.

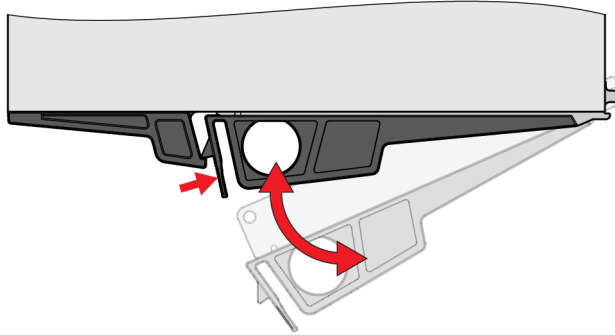

3. Pull the Controller out of the Engine.
4. Hold the replacement Controller in the same orientation as the one you removed.
5. Open the release latch lever all the way.
6. Slide the replacement Controller into its slot until it will go no further.
7. Close the lever until it clicks in place.

The Controller engages with the connector on the midplane. The Controller syncs with the other Controller (if present) and automatically receives the software and all the other system information from the system drives. This process can take up to 20 minutes. The system is fully usable during this time. In a single-Controller configuration, if the failed Controller was functioning as the System Director, the new Controller becomes the System Director.

8. Connect the cables to the replacement Controller (if necessary, refer to the notes you made before removing the cables).

Removing or Replacing a Chassis

If you have a system problem that cannot be fixed by replacing the other hardware components, the problem might be a faulty chassis. You can move the existing Media Packs, system drives, and Controllers to a new chassis.



Make sure to move the two system drives (SSDs) along with the Media Packs to the new chassis.

For Avid NEXIS Engines using media mirroring (engine protection), mirrored Workspaces can operate with one Engine offline. All media is available and accessible but not fully mirrored. If a replacement chassis is not available, perform a Remove Redistribution of the failed Engine to recreate the mirrored Workspaces, assuming there is enough free space on the remaining Engines. See the *Avid NEXIS Administration Guide* for information about performing redistribution.

To replace a chassis:

1. Open the Management Console and click System, then System Setup. Do the following:
 - a. Write down the hostname, IP address, and other important network details to reuse if you are replacing the failed chassis with a new one.
 - b. In the navigation sidebar, click Storage, then Controllers.
 - c. Double-click a Controller name to open the Advanced panel, then click the blue Tools tab.
 - d. In the Controller Shutdown field, enter the administrator password, then click Shutdown.
 - e. In the confirmation message, click Continue.
 - f. If a second Controller is installed, repeat steps e and f for the second Controller.



Shutting down both Controllers (or the only Controller in a chassis) shuts down the entire system and your login session will end until the system reboots.

- g. Continue with Step 3.
2. Make note of the locations of all Ethernet cables and disconnect them from the Controllers in the failed chassis.
3. Turn off the switches on all the power supply modules.
4. Disconnect all Ethernet cables and power cables from the failed chassis.
5. Carefully remove all the media drives, system drives, Controllers, and the power supplies and fans, if applicable, and put them in a safe place.
6. Remove the failed chassis from the rack.

To replace a chassis:

1. Install the new empty chassis into the rack.
2. Insert all the media drives and system drives from the old chassis into the new one.
3. Insert the Controllers and power supplies from the old chassis into the new one (see [“Avid NEXIS System Overview” on page 1](#) for the proper orientation of Controllers in the chassis).



When re-using a Controller in the same shared storage system, the IP address and software is recognized by the System Director and needs no reconfiguration.

4. Connect all Ethernet and power cables to the new chassis.
5. Turn on the new chassis.
Allow two minutes for the new chassis to initialize.



If any of the LEDs indicate an error, call Avid Customer Care.

6. Open the Management Console and verify that the Media Packs are online with a green icon and no status messages on the Media Packs page.



If any Status errors are listed, call Avid Customer Care.

7. Verify that media is available to the clients.

5 Specifications and Notices

This section provides information on the physical and electrical specifications for the Avid NEXIS Engines and the optional external System Director Appliance. Avid recommends the use of an Uninterruptible Power Supply (UPS) and supported network cabling.

Physical

Model	System Director Appliance	All other 2U Chassis ^a	All 4U Chassis ^b	All 5U Chassis ^c
Width	483 mm (19 in)	483 mm (19 in)	483 mm (19 in)	483 mm (19 in)
Depth	630 mm (24.8 in)	630 mm (24.8 in)	630 mm (24.8 in)	933 mm (36.75 in)
Height	88.9 mm (3.5 in)	88.9 mm (3.5 in)	177.8 mm (7 in)	220 mm (8.65 in)
Weight	16.7 kg (37 lb)	26 kg (57.2 lb) with drives	46 kg (101.41 lb) with drives	135 kg (298 lb) with drives

a. Avid NEXIS | E2, Avid NEXIS | E2 All-Mirror, Avid NEXIS | E2 SSD, Avid NEXIS | PRO

b. Avid NEXIS | E4, Avid NEXIS | E4 All-Mirror

c. Avid NEXIS | E5, Avid NEXIS | E5 All-Mirror, Avid NEXIS | E5 NL

Electrical and Power

UPS systems must specify a transfer time of <10ms in order to prevent power loss to the power supply modules. The power supply modules for an Engine should not be connected to the same UPS.

Model	System Director Appliance	All other 2U Chassis ^a	All 4U Chassis ^b	All 5U Chassis ^c
Power Supplies	Dual 764W	Dual 764W	Quad 580W	Dual 2200W
Voltage	100 to 240 Vac	100 to 240 Vac	100 to 240 Vac	200 to 240 Vac
Freq.	60/50 Hz	60/50 Hz	60/50 Hz	60/50 Hz
Power Conversion Efficiency (Consumption)	>80% @ 100V, >80% @ 240V (>30% load)	>80% @ 100V, >80% @ 240V (>30% load)	>83% @ 100V, >85% @ 240V (>30% load)	94% @ 240V (50% load)
Max Start-Up Power	764W	764W	1160W	2200W
BTU/Hr	2607	2607	3958	7507
Avg. Load Power	200W ^d	253W	512W	Not measured
BTU/Hr	683 ^e	863	1747	Not measured

- a. Avid NEXIS | E2, Avid NEXIS | E2 All-Mirror, Avid NEXIS | E2 SSD, Avid NEXIS | PRO
- b. Avid NEXIS | E4, Avid NEXIS | E4 All-Mirror
- c. Avid NEXIS | E5, Avid NEXIS | E5 All-Mirror, Avid NEXIS | E5 NL
- d. Estimated
- e. Estimated

Altitude and Temperature

Model	System Director Appliance	All other 2U Chassis ^a	All 4U Chassis ^b	All 5U Chassis ^c
Operating Temperature	5° to 40° C (41° to 104° F)	5° to 40° C (41° to 104° F)	5° to 40° C (41° to 104° F)	5° to 35°C (41° to 95° F)
Operating Humidity	8% to 80% non-condensing	8% to 80% non-condensing	20% to 80% non-condensing	10% to 80% non-condensing
Operating Altitude	0 to 3000 m (0 to 10,000 ft)	0 to 3000 m (0 to 10,000 ft)	0 to 3000 m (0 to 10,000 ft)	-100 to 3000m (-330 to 10,000 ft)
Non-operating Altitude	-300 to 12,192 m (-1000 to 40,000 ft)	-300 to 12,192 m (-1000 to 40,000 ft)	-300 to 12,192 m (-1000 to 40,000 ft)	-100 to 12,192m (-330 to 40,000 ft)

- a. Avid NEXIS | E2, Avid NEXIS | E2 All-Mirror, Avid NEXIS | E2 SSD, Avid NEXIS | PRO
- b. Avid NEXIS | E4, Avid NEXIS | E4 All-Mirror
- c. Avid NEXIS | E5, Avid NEXIS | E5 All-Mirror, Avid NEXIS | E5 NL

Shock, Vibration and Noise

Model	System Director Appliance	All other 2U Chassis ^a	All 4U Chassis ^b	All 5U Chassis ^c
Operational Shock	5g 10ms ½ Sine	5g 10ms ½ Sine	5g 10ms ½ Sine	5g 10ms ½ Sine
Operational Vibration	Random 0.21g RMS 5-500Hz	Random 0.21g RMS 5-500Hz	Random 0.21g RMS 5-500Hz	Random 0.21g RMS 5-500Hz
Non-operational Shock	20g 10ms ½ Sine	20g 10ms ½ Sine	30g 10ms ½ Sine	30g 10ms ½ Sine
Non-operational Vibration	Random 1.04g RMS 2-200Hz	Random 1.04g RMS 2-200Hz	Random 1.04g RMS 2-200Hz	Random 1.04g RMS 2-200Hz
Relocation Vibration	Swept Sine 0.3g 2-200Hz	Swept Sine 0.3g 2-200Hz	Swept Sine 0.3g 2-200Hz	Swept Sine 0.3g 2-200Hz
Acoustics	Sound power operating < 6.5 Bels LWAd @ 23°C	Sound power operating < 6.5 Bels LWAd @ 23°C	Sound power operating < 7.2Bels LWAd @ 23°C	Sound power operating < 8.0Bels LWAd @ 23°C

- a. Avid NEXIS | E2, Avid NEXIS | E2 All-Mirror, Avid NEXIS | E2 SSD, Avid NEXIS | PRO
- b. Avid NEXIS | E4, Avid NEXIS | E4 All-Mirror
- c. Avid NEXIS | E5, Avid NEXIS | E5 All-Mirror, Avid NEXIS | E5 NL

Approvals

Model	System Director Appliance	All other 2U Chassis ^a	All 4U Chassis ^b	All 5U Chassis ^c
EMC	FCC pt15B Class A, EN55022 Class A, CISPR 22 Class A, EN 55024, CISPR24, EN61000-3-2/3, CNS13438			
Safety	EN/IEC/UL 60950-1, CNS14336 CB report: CE, UL, cUL, FCC, BSMI, VCCI, CCC (PSU only)			

- a. Avid NEXIS | E2, Avid NEXIS | E2 All-Mirror, Avid NEXIS | E2 SSD, Avid NEXIS | PRO
- b. Avid NEXIS | E4, Avid NEXIS | E4 All-Mirror
- c. Avid NEXIS | E5, Avid NEXIS | E5 All-Mirror, Avid NEXIS | E5 NL

Uninterruptible Power Supply (UPS)

Avid highly recommends you create a separate derived power system for your Avid NEXIS. This provides protection against sudden power surges or losses that could cause you to lose files or experience data corruption. The power outlets must be served by the same distribution panel. This helps prevent ground loops that can be caused by plugging equipment into power sources with different ground potentials.

See “[Power Supplies](#)” on page 22 for more information, and provide a UPS that meets the power requirements of each individual power supply module in the Engines in your environment. Make sure there is adequate, dedicated power for each UPS.











Make sure all the electrical work at your site is done by a licensed electrician. The electrical changes must meet country, state, and local electrical codes.

6 Safety and Regulatory Information

This document contains safety and regulatory information for Avid NEXIS hardware.

Warnings and Cautions

-  **This equipment is intended only for installation in a RESTRICTED ACCESS LOCATION.**
-  **Never install equipment if it appears damaged.**
-  **Disconnect the power cord before servicing unit.**
-  **Only perform the services explicitly described in this document. For services or procedures not outlined in this document, speak with authorized Avid service personnel.**
-  **Follow all warnings and cautions in the procedures.**
-  **Operate the device within its marked electrical ratings and product usage instructions.**
-  **If you need to replace a battery in an Avid hardware unit, be sure to use the correct battery type. There might be a risk of explosion if a battery is replaced by an incorrect type. Dispose of used batteries according to the manufacturer's instructions.**
-  **For products with a power switch the main power switch should remain accessible after installation.**

Proposition 65 Warning

This product contains chemicals known to the State of California to cause cancer and birth defects or other reproductive harm.

FCC Notice

Part 15 of the Federal Communication Commission Rules and Regulations has established Radio Frequency (RF) emission limits to provide an interference free radio frequency spectrum. Many electronic devices produce RF energy incidental to their intended purpose. These rules place electronic equipment into two classes, A and B, depending on the intended use.

Class A devices are those that may be expected to be installed in a business or commercial environment. Class B devices are those that may be expected to be installed in a home or residential environment. The FCC requires devices in both classes to be labeled with the interference likelihood and additional operating instructions. The rating label on the equipment will show which class the product is (A or B). Class A product will not have an FCC logo. Class B equipment will have an FCC logo. The information statements differ on the two classes.

Class A Equipment

This equipment has been tested and found to comply with the limits for a Class A digital device, pursuant to Part 15 of the FCC rules. These limits are designed to provide reasonable protection against harmful interference when the equipment is operated in a commercial environment. This equipment generates, uses, and can radiate radio frequency energy and, if not installed and used in accordance with the instructions, may cause harmful interference to radio communications. Operation of this equipment in a residential area is likely to cause harmful interference, in which case the user will be required to correct the interference at personal expense.

Class B Equipment

This equipment has been tested and found to comply with the limits for a Class B digital device, pursuant to Part 15 of the FCC Rules. These limits are designed to provide reasonable protection against harmful interference in a residential installation. This equipment generates, uses, and can radiate radio frequency energy and, if not installed and used in accordance with the instructions, may cause harmful interference to radio communications. However, there is no guarantee that interference will not occur in a particular installation. If this equipment does cause harmful interference to radio or television reception, which can be determined by turning the equipment off and on, the user is encouraged to try to correct the interference by one or more of the following measures:

- Reorient or relocate the receiving antenna
- Increase the separation between the equipment and receiver
- Connect the equipment into an outlet on a circuit different from that to which the receiver is connected
- Consult the dealer or an experienced radio or television technician for help

Modifications

The FCC requires the user to be notified that any changes or modifications made to Avid hardware that are not expressly approved by Avid Technology may void the user's authority to operate the equipment.

Cables

Connections to Avid hardware must be made with shielded cables with metallic RFI/EMI connector hoods in order to maintain compliance with FCC Rules and Regulations.

Canadian Notice (Avis Canadien)

Class A Equipment

This Class A digital apparatus meets all requirements of the Canadian Interference-Causing Equipment Regulations.

Cet appareil numérique de la classe A respecte toutes les exigences du Règlement sur le matériel brouilleur du Canada.

Class B Equipment

This Class B digital apparatus meets all requirements of the Canadian Interference-Causing Equipment Regulations.

Cet appareil numérique de la classe B respecte toutes les exigences du Règlement sur le matériel brouilleur du Canada.

LED Safety Notices



Avid hardware might contain LED or Laser devices for communication use. These devices are compliant with the requirements for Class 1 LED and Laser Products and are safe in the intended use. In normal operation the output of these laser devices does not exceed the exposure limit of the eye and cannot cause harm.

Standard to which conformity is declared: (Class 1 LED Product per IEC 60825-1:2007)

European Union Declaration of Conformity



Declaration of conformity
 Konformitätserklärung
 Déclaration de conformité
 Declaración de Confomidad
 Verklaring de overeenstemming
 Dichiarazione di conformità

We/Wir/Nous/WIJ/Noi:

Avid Technology
 75 Network Drive
 Burlington, MA, 01803 USA

European Contact: Nearest Avid Sales and Service Office or
 Avid Technology International B.V.
 Sandyford Industrial Estate
 Unit 38, Carmanhall Road
 Dublin 18, Ireland

declare under our sole responsibility that the product,
 erklären, in alleniniger Verantwortung, daß dieses Produkt,
 déclarons sous notre seule responsabilité que le produit,

declaramos, bajo nuestra sola responsabilidad, que el producto,
 verklaren onder onze verantwoordelijkheid, dat het product,
 dichiariamo sotto nostra unica responsabilità, che il prodotto,

Product Name	Model Number
Avid NEXIS PRO	9900-65604-XX, 9900-71318-XX
Avid NEXIS E2	9900-65696-XX
Avid NEXIS E2 SSD	9900-71302-XX
Avid NEXIS E2 All-Mirror	9900-74147-XX
Avid NEXIS E4	9900-65603-XX
Avid NEXIS E4 All-Mirror	9900-74148-XX
Avid NEXIS E5	9900-65605-XX, 9900-65617-XX
Avid NEXIS E5 All-Mirror	9900-74149-XX
Avid NEXIS E5 NL	9900-71327-XX
System Director Appliance	9900-65697-XX

Product Option(s): This declaration covers all options for the above product(s).

to which this declaration relates is in conformity with the following standard(s) or other normative documents.

auf das sich diese Erklärung bezieht, mit der/den folgenden Norm(en) oder Richtlinie(n) übereinstimmt.

auquel se réfère cette déclaration est conforme à la (aux) norme(s) ou au(x) document(s) normatif(s).

al que se refiere esta declaración es conforme a la(s) norma(s) u otro(s) documento(s) normativo(s).

waarnaar deze verklaring verwijst, aan de volende norm(en) of richtlijn(en) beantwoordt.

a cui si riferisce questa dichiarazione è conforme alla/e seguente/i norma/o documento/i normativo/i.

The requirements of the European Council:

Safety: Directive 2006/95/EC

UL 60950-1, 2nd edition

CAN/CSA-C22.2 No. 60950-1-07; 2007

IEC 60950-1, 2nd edition

EN 60950-1:2006

EMC: Directive 2004/108/EC

EN55022:2006 /A1:2007

EN55024:1998 /A1:2001 /A2:2003

EN61000-3-2:2006

EN61000-3-3:2008

Issued In Burlington MA, USA 2011

Disposal of Waste Equipment by Users in the European Union



This symbol on the product or its packaging indicates that this product must not be disposed of with other waste. Instead, it is your responsibility to dispose of your waste equipment by handing it over to a designated collection point for the recycling of waste electrical and electronic equipment. The separate collection and recycling of your waste equipment at the time of disposal will help conserve natural resources and ensure that it is recycled in a manner that protects human health and the environment. For more information about where you can drop off your waste equipment for recycling, please contact your local city recycling office or the dealer from whom you purchased the product.

Argentina Conformity



Made in USA

Australia and New Zealand EMC Regulations

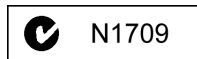

Ken Hopkins
Avid Technology (Aust) Pty Ltd
c/o – Elliot House
Suite 810, Level 8
140 Arther St
North Sydney
NSW – 2060

Japan EMC Regulations

Class A Equipment

This is a Class A product. In a domestic environment this product may cause radio interference in which case the user may be required to take corrective actions. VCCI-A

この装置は、クラスA情報技術装置です。この装置を家庭環境で使用すると電波妨害を引き起こすことがあります。この場合には使用者が適切な対策を講ずるよう要求されることがあります。 VCCI-A

Korean EMC Regulations

Class A Equipment

Please note that this equipment has obtained EMC registration for commercial use. In the event that it has been mistakenly sold or purchased, please exchange it for equipment certified for home use.

이 기기는 업무용(A급) 전자파적합기기로서 판매자 또는 사용자는 이 점을 주의하시기 바라며, 가정외의 지역에서 사용하는 것을 목적으로 합니다.

Taiwan EMC Regulations

Taiwan EMC Regulations BSMI Class A EMC Warning

警告使用者：

這是甲類的資訊產品，在居住的環境中使用時，可能會造成射頻干擾，在這種情況下，使用者會被要求採取某些適當的對策。

Warning Statement

1. UV ray radiation

- Following statement or equivalent:

警告：開啓前請先關閉UV 燈

- Following marking or other equivalent marking:



2. Operator touchable area protection

Operation manual should have following statement and statement should be shown on device, or put on similar sentence:

警告

危險可動部位

請遠離手指及身體其他部位

3. Heat-related hazards

Injury may result from high temperatures under normal operating conditions, causing:

- Burns due to contact with hot accessible parts
- Degradation of insulation and of safety-critical components
- Ignition of flammable liquids

Examples of measures to reduce risks include:

- Taking steps to avoid high temperature of accessible parts
- Avoiding temperatures above the ignition point of liquids
- Provision of marking to warn USERS where access to hot parts is unavoidable

High temperature warning marking — you may use the following high temperature warning marking:



4. Mechanical hazards

Injury may result from:

- Sharp edges and corners
- Moving parts which have the potential to cause injury
- Equipment instability
- Flying particles from imploding cathode ray tubes and exploding high pressure lamps

Examples of measures to reduce risks include:

- Rounding of sharp edges and corners
- Guarding
- Provision of SAFETY INTERLOCKS
- Providing sufficient stability to free-standing equipment
- Selecting cathode ray tubes and high pressure lamps that are resistant to implosion and explosion respectively
- Provision of markings to warn USERS where access is unavoidable

5. Radiation

Injury to USERS and to SERVICE PERSONS may result from some forms of radiation emitted by equipment.

Examples are sonic (acoustic), radio frequency, infra-red, ultraviolet and ionizing radiation, and high intensity visible and coherent light (lasers).

Examples of measures to reduce risks include:

- Limiting the energy level of potential radiation sources
- Screening radiation sources
- Provision of SAFETY INTERLOCKS
- Provision of markings to warn USERS where exposure to the radiation hazard is unavoidable

6. Chemical hazards

Injury may result from contact with some chemicals or from inhalation of their vapors and fumes.

Examples of measures to reduce risks include:

- Avoiding the use of constructional and consumable materials likely to cause injury by contact or inhalation during intended and normal conditions of use
- Avoiding conditions likely to cause leakage or vaporization
- Provision of markings to warn USERS about the hazards

7. Safety warning statement for equipment that is under hazardous voltages

8. Equipment with touch current exceeding 3.5 mA

One of the following labels, or a label with similar wording, shall be affixed adjacent to the equipment AC MAINS SUPPLY connection:

警告

高漏電流

在連接電源前須確實接地

9. An EUT that provides TELECOMMUNICATIONS NETWORK connection ports for connection of multiple items of other telecommunications equipment shall not create a hazard for USERS and TELECOMMUNICATIONS NETWORK SERVICE PERSONS due to summation of TOUCH CURRENT

警告
高漏電流
在連接電信網路
前須確實接地

警告
高接觸電流
在連接電信網路
前須確實接地

10. Replaceable batteries

If an equipment is provided with a replaceable battery, and if replacement by an incorrect type could result in an explosion (for example, with some lithium batteries), the following applies:

- If the battery is placed in an OPERATOR ACCESS AREA, there shall be a marking close to the battery or a statement in both the operating and the servicing instructions
- If the battery is placed elsewhere in the equipment, there shall be a marking close to the battery or a statement in the servicing instructions

The marking or statement shall include the following or similar text:

警 告
本電池如果更換不正確會有爆炸的危險
請依製造商說明書處理用過之電池

11. Warning to service persons

Suitable markings shall be provided on the equipment or a statement shall be provided in the servicing instructions to alert a SERVICE PERSON to a possible hazard, where both of the following conditions exist:

- Where a fuse is used in the neutral of single-phase equipment either permanently connected or provided with a non-reversible plug
- Where, after operation of the fuse, parts of the equipment that remain energized might represent a hazard during servicing

The following or similar wording is regarded as suitable:

注意

雙極性 / 中性線已接熔線

Index

Numerics

- 2U chassis
 - Control panel 9
 - controller location 6
 - drive numbering 5
 - front view 5
 - rear view 6
 - system drives location 5
 - 4U chassis
 - Control panel 9
 - drive numbering 8
 - front view 8
 - rear view 8
 - system drives location 8
 - 5U chassis
 - control panel 10
 - controller location 13
 - drive drawer panel 11
 - drive numbering 12
 - front view 10
 - rear view 13
 - sideplane panel 11
- A**
- Accidental drive removal 52
 - Adding Engines to system 49
 - Agent
 - access to Setup Wizard 47
 - Agent password
 - changing 46
 - anti-static wrist or ankle strap 48
 - Argentina Conformity 70
 - Attaching the bezel 53
 - Australia EMC regulations 70
 - Avid
 - online support viii
 - training services viii
 - Avid NEXIS E5
 - Engine status and control panel 10
 - Avid NEXIS platforms, overview 1

B

- Bezel
 - attaching 53
 - removing 53

C

- Cables, space for connecting 27
- Canadian
 - interference causing equipment regulations 67, 70, 71
- Chassis *See* Engine
- Clearance around equipment 27
- Computer
 - configuring IP address 40
 - connecting to Avid NEXIS Engine 40
- Configuring
 - Engine 43
 - IP address on computer for setup 40
- Connecting cables 27
- Control panel 9
 - 2U chassis 9
 - 5U chassis 10
- Controller
 - failures 60
 - function 18
 - IP addresses 37
 - location
 - 2U 6
 - 2U chassis 5
 - 4U chassis 8
 - name, about 38
 - redundant 18
 - installing 57
 - replacing 60
 - single, and system operation 60
 - slot requirements for 5U chassis 60
 - switchover time 60
 - types 13
- Controller location
 - 5U chassis 13
- Controller password 18
- Cooling modules
 - LEDs 22
 - status 22

D

- Default password 18
- Dimensions 63
- DNS
 - domain name
 - search list
 - servers
- Domain Name Service

- See DNS
- Downloading software kit 40
- Drive numbering
 - 2U chassis 5
 - 5U 12

- Drives
 - anti-tamper lock 19
 - capacity 19
 - carriers 21
 - drawer panel (5U) 11
 - failures
 - and Workspace protection 51
 - indicators 51
 - system behavior 51
 - installing 31
 - installing, 5U 31
 - label 19
 - LEDs 19
 - Media Pack
 - capacity 19
 - Media Packs 19
 - numbering
 - 2U chassis 5
 - 4U 8
 - removing 52
 - removing by accident 52
 - replacing 52
 - status 19
 - system
 - capacity 19
 - replacement size 54
 - type 19

E

- EIA rack units 27
- Enabling link aggregation 35
- Engine
 - adding to existing storage system 49
 - configuring 43
 - connecting to switch 33
 - cooling modules 22
 - front view (4U) 8
 - input/mute switch 9
 - installing software 43
 - name 38
 - power supplies 8, 13
 - rear view (4U) 8
 - unit ID LED 9
- Engine protection for Workspaces 3
- ESD precautions 49
- European Union notice 68
- Expanding a system 49
- Extracting software kit 40

F

- FCC notice 66
- Front view
 - 2U chassis 5
 - 4U chassis 8
 - 5U chassis 10
 - System Director Appliance 5

G

- Gateway and netmask 37

H

- Hardware
 - faults 48
 - status LEDs 48
- Hostname
 - allowed characters 37
 - max length 37
 - System Director 37

I

- Installation overview 39
- Installing
 - Media Packs (2U, 4U) 31
 - Media Packs (5U) 31
 - redundant Controller 57
 - software 43
- IP address
 - for computer used in setup 40
 - NTP servers 37
 - System Director 38

L

- LACP 33
 - about 35
- LEDs
 - Engine ID 9
 - hardware status 48
- Link aggregation 33
 - about 35
 - enabling 35
 - ports 18
- Link bundling
 - See Link aggregation

M

- Management port, connecting computer to 40
- Media Pack drive capacity 19
- Media Packs
 - about 19

- adding to a system 49
- capacity 19
- drives
 - labels 19
 - replacement size 54
 - type 19

N

- Netmask and gateway 37
- New Zealand EMC regulations 70
- NIC teaming 33
 - See Link aggregation
- NTP servers, IP addresses 37

O

- Online support viii

P

- Password
 - Controller 18
 - default 18
- Port trunking
 - See Link aggregation
- Power supplies
 - Engines 22
 - LEDs 22
 - location 8, 13
 - removing 55
 - replacing 55
 - status 22
- Proposition 65 warning 66

R

- Rack requirements 27
- Rear view
 - 2U chassis 6
 - 4U chassis 8
 - 5U chassis 13
- Redundant networking
 - See Link aggregation
- Regulatory information 66
 - Australia and New Zealand 66
 - California Prop 65 66
 - FCC Notice 66
 - Japan 66
 - Korea 66
 - Taiwan 66
- Removing
 - bezel 53
 - Controller 61
 - drives 52
 - Engine 61

- power supply 55
- Replacing
 - bezel 53
 - Controller 60
 - drives 52
 - Engine 61
 - power supply 55
- Requirements for rack mounting 27
- Running Setup Wizard 47

S

- Safety information 66
- Serial number
 - location on chassis 5
- Servicing, space for 27
- Setup Wizard 47
- Sideplane panel (5U) 11
- Software
 - installing 43
- Software kit
 - contents 40
 - downloading 40
 - extracting 40
- Space for accessing components 27
- Specifications
 - altitude and temperature 63
 - approvals 63
 - dimensions and weights 63
 - electrical 63
 - shock and vibration 63
 - UPS recommendation 63
- Storage System Name
 - about 38
 - allowed characters 37
 - defined 37
 - length 37
- Supported configurations
 - Media Mirroring (Engine protection for Workspaces) 3
 - with embedded System Director 3
 - with System Director Appliance 3
- Switch
 - connecting to Engine 33
 - link aggregation (LACP) 33
 - required hardware 33
- Switchover time (Controllers) 60
- System
 - adding Engines 49
 - adding Media Packs 49
 - expanding 49
- System details 5
- System Director 2
 - functions 2
 - IP address 38
 - name (hostname) 37, 38
- System Director Appliance

See Avid NEXIS SDA
System drives
 capacity 19
 default location
 2U chassis 5
 4U chassis 8
 default location (5U) 31
 label 19
 replacement size 54

T

Taiwan EMC regulations 71
Training services viii
Troubleshooting viii

W

Weight 63
Wizard, Setup 47